

2011

Bab edh-Dhra', Numeira, and the Biblical Patriarchs: a Chronological Study

Kris J. Udd
Andrews University

Follow this and additional works at: <https://digitalcommons.andrews.edu/dissertations>

 Part of the [Biblical Studies Commons](#), [History of Art, Architecture, and Archaeology Commons](#), and the [Near Eastern Languages and Societies Commons](#)

Recommended Citation

Udd, Kris J., "Bab edh-Dhra', Numeira, and the Biblical Patriarchs: a Chronological Study" (2011). *Dissertations*. 157.
<https://digitalcommons.andrews.edu/dissertations/157>

This Dissertation is brought to you for free and open access by the Graduate Research at Digital Commons @ Andrews University. It has been accepted for inclusion in Dissertations by an authorized administrator of Digital Commons @ Andrews University. For more information, please contact repository@andrews.edu.



Seek Knowledge. Affirm Faith. Change the World.

Thank you for your interest in the

**Andrews University Digital Library
of Dissertations and Theses.**

*Please honor the copyright of this document by
not duplicating or distributing additional copies
in any form without the author's express written
permission. Thanks for your cooperation.*

ABSTRACT

BAB EDH-DHRA', NUMEIRA, AND THE BIBLICAL PATRIARCHS:
A CHRONOLOGICAL STUDY

by

Kris J. Udd

Chair: Randall W. Younker

ABSTRACT OF GRADUATE STUDENT RESEARCH

Dissertation

Andrews University

Seventh-day Adventist Theological Seminary

Title: BAB EDH-DHRA', NUMEIRA, AND THE BIBLICAL PATRIARCHS: A
CHRONOLOGICAL STUDY

Name of researcher: Kris J. Udd

Name and degree of faculty chair: Randall W. Younker, Ph.D.

Date completed: December 2011

Problem

Bab edh-Dhra' and Numeira have been identified by archaeologists as possible candidates for two of the biblical cities of the plain, but their existence in the Early Bronze Age III is too early to match the biblical narrative (Gen 19) by many chronologies of ancient Canaan. This study sought to determine if there is sufficient flexibility in the archaeological and biblical chronologies to make the identification of Bab edh-Dhra' and Numeira with the cities of the plain a viable interpretation.

Method

The range of dates possible for both the archaeological data and the biblical narratives was analyzed. For the archaeological data this involved a study of the absolute dates for contemporary periods in Mesopotamia and Egypt, with particular emphasis on the trends in

dating for both areas over the last century or so, as well as a study of radiocarbon dating in the region for this time period. For the biblical narratives the study consisted of a review of the spectrum of absolute dates that have been suggested for the patriarchs. The results of these two datasets were then compared for possible overlap.

Results

Chronologies for both Mesopotamia and Egypt have been steadily lowered over the past century, and it is not clear that the trend is over. This trend has not been yet fully embraced by mainstream archaeology in Syria/Palestine. Radiocarbon was found to generally favor higher dates, but the method has problems that render it inconclusive by itself. The absolute dates possible for the patriarchs span a lengthy period, the early end of which may overlap the newer low chronologies for Mesopotamia and Egypt.

Conclusions

Combining the new lower archaeological chronologies and the higher dates for the patriarchs indicates the possibility that Bab edh-Dhra' and Numeira could be two of the biblical cities of the plain. Further investigation into this possible identification is merited.

Andrews University
Seventh-day Adventist Theological Seminary

BAB EDH-DHRA', NUMEIRA, AND THE BIBLICAL PATRIARCHS:
A CHRONOLOGICAL STUDY

A Dissertation
Presented in Partial Fulfillment
of the Requirements for the Degree
Doctor of Philosophy

by

Kris J. Udd

December 2011

©Copyright by Kris J. Udd 2011

All Rights Reserved

BAB EDH-DHRA', NUMEIRA, AND THE BIBLICAL PATRIARCHS:

A CHRONOLOGICAL STUDY

A dissertation
presented in partial fulfillment
of the requirements for the degree
Doctor of Philosophy

by

Kris J. Udd

APPROVAL BY THE COMMITTEE

Faculty Adviser,
Randall W. Younker
Professor of Old Testament and Biblical Archaeology

Director, PhD: Biblical & ANE Archaeology
Randall W. Younker

Paul Ray
Adjunct Professor of Archaeology

Dean, SDA Theological Seminary
Denis Fortin

Richard M. Davidson
J. N. Andrews Professor of Old Testament Interpretation

Øystein S. LaBianca
Professor of Anthropology

Lawrence T. Geraty
Professor of Archaeology and Old Testament Studies
La Sierra University

Date approved

TABLE OF CONTENTS

LIST OF ILLUSTRATIONS		x
Chapter		
I. INTRODUCTION		1
Statement of the Problem		3
Purpose of the Study		5
Justification of the Study		5
Methodology		6
Establish the EB III and IV Archaeological Context of Bab edh-Dhra' and Numeira		6
Establish the Range of Possible Absolute Dates for the End of the EB III		7
Establish the Possible Chronologies for the Patriarchs		7
Analyze the Data for Possible Overlap; Summarize Results		7
Assumptions		8
II. CHARACTER AND CHRONOLOGY OF BAB EDH-DHRA' AND NUMEIRA		9
History of Exploration		9
Overview of Bab edh-Dhra'		12
Geographical Setting		12
Occupational History		14
Final Destruction and Abandonment		18
Overview of Numeira		20
Geographical Setting		20
Occupational History		21
Final Destruction and Abandonment		22
Chronological Indicators for Bab edh-Dhra' and Numeira		23
Relative Chronology		23
EB I		23
EB II		24
EB III		27
EB IV		29

Summary	34
Absolute Chronology	34
Radiocarbon Determinations	34
Historical Synchronizations	38
III. ABSOLUTE CHRONOLOGY FOR THE EARLY BRONZE AGE III–IV TRANSITION IN THE LEVANT	40
Foreign Synchronisms	41
Mesopotamian Chronology	41
Egyptian Chronology	47
Synchronisms	53
Middle Kingdom: Dynasty 13	53
Middle Kingdom: Dynasty 12	54
First Intermediate Period	56
Old Kingdom: Dynasties 4-6	57
PreDynastic Egypt: Dynasties 1-3	59
Summary	60
Radiocarbon Dates in the Levant	61
Basics of Radiocarbon	62
History	62
Assumptions	67
Inherent Weaknesses	69
Known Causes of Variation	70
Use of Radiocarbon	73
¹⁴ C Dates Too Imprecise	75
¹⁴ C Dates Too Old	79
¹⁴ C Dates Too Inconsistent	89
Iron Age Test Case—Tel Rehov	96
MB/LB Test Case—Thera	99
Absolute Dates for the EB III/EB IV Transition	105
Summary: Feasible High and Low Estimates	109
IV. ABSOLUTE CHRONOLOGY AND ABRAHAM	111
Biblical Evidence	111
Non-Biblical Evidence	114
Merneptah Stele	114
“Shasu of Yahweh”	115
Berlin Statue Pedestal Relief 21687	118
Excavation of Various Sites	120
Climate Change and Early Geography	121
Cultural/Sociological Indicators	123
Proposed Chronological Schemes	126
Iron Age	126

1425 B.C.	128
1675–1900 B.C.	130
1950 B.C.	133
2000 B.C.	134
2165 B.C.	135
2350 B.C.	136
Summary: Feasible Range of Schemes	137
 V. SUMMARY	 139
Comparison of the Archaeological and Biblical Data	139
Mesopotamia	139
Egypt	140
The Levant	140
The Patriarchs	141
Implications for Biblical Chronology	143
Implications for Archaeology	143
Areas for Future Inquiry	145
Chronology	145
Exploration in the Southern Ghor	146
 Appendix	
A. RULERS OF EGYPT	148
B. MESOPOTAMIAN CHRONOLOGY	150
 BIBLIOGRAPHY	 152

LIST OF ILLUSTRATIONS

1. Early Bronze Sites in the Southeastern Dead Sea Plain	10
2. Plan of the Town Site of Bab edh-Dhra'	13
3. Abydos Jars from Tel el-Far'ah North and from Bab edh-Dhra'	16
4. Map Showing the Location of the EB IV 'Aro'er and Khirbet Iskander.....	19
5. Map of Numeira.....	20
6. Major Forms of the Early Bronze I at Bab edh-Dhra'	25
7. Major Forms of the Early Bronze II at Bab edh-Dhra'	26
8. Major Forms of the Early Bronze III at Bab edh-Dhra'	28
9. Flared-rim Pot (EB III) from Bab edh-Dhra'	29
10. Steatite Seal and Impression	30
11. Major Forms of the Early Bronze IV at Bab edh-Dhra'	31
12. Thin-rim Bowls from EB IV Tomb A 54 at Bab edh-Dhra'	32
13. Votive Bowl from EB IV Tomb A 54 at Bab edh-Dhra'	33
14. Combed, handled jars from EB IV Tomb A 54 at Bab edh-Dhra'	33
15. Radiocarbon Dates from Bab edh-Dhra' and Numeira.....	35
16. Estimated Lengths of the Egyptian Periods	51
17. The 1970 Radiocarbon Calibration Curve	65
18. The INTCAL04 Calibration Curve.....	66
19. Variation of Date Results by Laboratory Type.....	71

20. Dates from the 1987 Study by Haas et al.....	81
21. Offset Between ¹⁴ C and <i>Cambridge Ancient History</i>	81
22. Offset Between ¹⁴ C Dates and Archaeo-Historical Ages	83
23. Offsets of Calibrated 1σ ¹⁴ C Dates and Distirical Dates.....	85
24. Offsets Between 14C and Historically Derived Dates from Tell el-Dab‘a	86
25. Radiocarbon Determinations From the Reed Mat, Cave of the Treasure.....	91
26. Radiocarbon Determinations from Khirbet Iskander.....	93
27. Initial Placement of Strata from Tel Rehov on the ¹⁴ C Calibration Curve	97
28. Comparison of Mazar’s and Finkelstein’s ¹⁴ C Dates for Tel Rehov	98
29. Response of Mazar with Broader ¹⁴ C Bands.	100
30. Actual Range for the Average ¹⁴ C for Stratum VI, Locus 4426 at Tel Rehov	100
31. Averaged Date Ranges of 25 Radiocarbon Determinations from Akrotiri.....	101
32. Differences Between Radiocarbon and Archaeo-Historically Derived Dates	104
33. Sequence of Phases at Tell el-Dab‘a.....	106
34. Proposed Gaps on Either Side of the EB IV Along the Coast of Israel.....	109
35. Text of the Merneptah Stele.....	114
36. Two Name Rings of the “Shasu of Yahweh” from Soleb	116
37. Text of the “Shasu of Yahweh” Inscription.....	116
38. Text of the Israel Inscription in the Egyptian Museum Berlin	118
39. Text and Translation of the First Two Name Rings in the Israel Inscription	118
40. Text and Translation of the Third Name Ring in the Israel Inscription.....	119
41. Comparison of Various Dates Suggested for the Patriarchs	138
42. Proposed Chronological Schemes.....	142

LIST OF TABLES

1. Sample Offsets for Various ANE Sites and Periods.....	88
2. Selected OT Chronological References	112
3. Selected NT Chronological References	113
4. Comparison of Selected Sojourn Genealogies.....	130

CHAPTER 1

INTRODUCTION

Very few events in the lives of the patriarchs are of the sort that might be expected to leave evidence in the archaeological record. The sacrifice of Isaac, the pastoral camp-sites of the patriarchs in the Judean hill country, the trips to Egypt—none of these events are the kind that would leave extensive and traceable remains that might be recovered thousands of years later. However, there are a few events from the lives of the patriarchs that are different. The destruction of Sodom and Gomorrah is one of them (Kitchen and Mitchell 1980: 269).¹ That event is described in Gen 19 as a fiery and overwhelming destruction of those cities, the very kind of catastrophe that often preserves a site for the archaeologist's spade. It is therefore a potentially vital link between archaeology and the biblical account of Abraham. The importance of correctly identifying those cities, if they can be found, can hardly be overestimated.

Several regions have been suggested for the location of Sodom and Gomorrah. Strabo placed the cities somewhere on the western side of the Dead Sea, probably in the area of Masada (*Judea*, iii, 183), a location backed by Walcott (cited in Clapp 1936: 323).

¹ Another potential source, but one which has so far proved unfruitful, is the identification of the four kings of Gen 14, Amraphel, Arioch, Chedorlaomer, and Tidal. Although numerous attempts have been made to match these kings to rulers known from extra-biblical documents (e.g., Gruenthaner 1942), so far the effort has been unproductive (see Provan, Long, and Longman 2003:119-121 and sources cited there).

However, no Early Bronze Age (EB) or Middle Bronze Age (MB) sites have been discovered in this area.

A second view is that the cities were located north of the Dead Sea, somewhere within the Jordan River valley. The strongest argument for this position is that the Genesis account mentions the “valley of the Jordan” in conjunction with these cities (Gen 13:10-12). “The mention of the Jordan is conclusive as to the situation of the district, for the Jordan ceases where it enters the Dead Sea, and can have no existence south of that point” (Grove 1884: 642). However, EB and MB sites are also lacking in this area, and the geological features ascribed to the area surrounding the cities of the plain, such as bitumen and salt (Gen 14:10; 19:26), are found only south of the Lisan.

As early as the 1920s Albright suggested that the cities may have been submerged beneath the waters at the southern end of the Dead Sea (Kyle 1928: 138; Albright 1974: 134-5). This suggestion echoed a belief that has a lengthy tradition, extending as far back as the first century A.D. (Josephus *Antiquities* 1.9). However, the recent drying up of the southern basin has allowed for exploration of this area and has shown the theory to lack any evidence. Furthermore, Albright himself pointed out that “more than one town in the same stream-basin was impossible, since the conflict over water-rights would effectually eliminate any attempt at competition in a very short time” (Albright 1974: 135-6). It was not then known that EB sites existed further upstream, but the subsequent discovery of additional sites is perhaps the strongest argument against the submersion theory (see below).

Finally, from at least the Byzantine era there has been a tradition that has placed the cities along the southeastern shore of the Dead Sea. This theory has been

reinvigorated recently with the discovery of EB remains in that area. Five EB sites were identified along the southeastern rim of the Dead Sea basin, known as the southern Ghor, in an archaeological survey conducted in 1973 (Rast and Schaub 1974: 6). Two of these sites were excavated between 1965 and 1981, first by Paul Lapp (1965-67) and later by Walter Rast and Thomas Schaub (intermittently from 1973-1981). Rast and Schaub suggested that these cities may be associated with the biblical cities of the plain mentioned in Gen 19:29 (Rast and Schaub 1974: 19; Schaub 1993: 130; Rast 2003: 328-9). The existence of five and only five EB sites in this area has encouraged further consideration of this theory, although Bab edh-Dhra' and Numeira are the only two sites to have been both excavated and published.

Statement of the Problem

Rast and Schaub have raised the possibility that Bab edh-Dhra' and Numeira may be two of the cities of the plain. Although Rast and Schaub have suggested an etiological explanation rather than a literal connection (Schaub 1993: 130), their identification remains an important one for biblical scholars. However, for those who accept the reliability of the biblical account, there is a significant chronological issue that exists.

In broad terms the date for the end of the Early Bronze Age III (EB III), when these cities appear to have been destroyed and largely abandoned, is often placed around 2200-2300 B.C. (for example, Meyers 1997: 411; Stern 1993: 1529), although this is an estimate rather than a certain date. The uncertainty of what absolute date should be assigned to the end of the EB III is evidenced by the broad range of dates that has been suggested for this transition. Estimates range from as early as 2400 (Adams 2000: 383) to as late as 2000 (Albright 1974: 10), with the majority of archaeologists settling

somewhere in the mid-range. Some archaeologists have not been willing to assign a specific date, preferring instead to use a range of dates to represent the end of the period, such as 2300-2150 (Lapp 1968: 27).

Dates for the patriarchal period have been subject to similar discussion. Working from the biblical data, the birth of Abraham has been variously estimated from as early as 2166 B.C. (Merrill 1980: 242; Rasmussen 1989: 76) to as late as 1952 B.C. (Hoerth 1998: 57), a difference of over 200 years. Scholars who have not felt the necessity of accommodating the biblical data have suggested an even broader range of dates, ranging from the 24th century B.C. (van Hattem 1981: 89) to the 15th century B.C. (Gordon 1953: 103), a span of nearly a thousand years.

According to the biblical account, the destruction of Sodom and Gomorrah occurred when Abraham was about 100 years old, just prior to the birth of Isaac (Gen 18). Thus the destruction of those cities would have occurred between 2067 and 1853 B.C., depending on which of the biblical chronological systems is employed.

When the archaeological timeframe for the end of the EB III is combined with the patriarchal dates proposed by biblical scholars, there is an apparent chronological inconsistency. As Khouri has summarized, “The date of the archaeological remains in south Jordan appears to be out of sequence with the generally accepted date for the Abrahamic period. . . . The major destruction levels at Bab edh-Dhra' and Numeira date from around 2350 B.C.—that is, 400-500 years earlier than the generally accepted dates for Abrahamic times” (Khouri 2003: 13).

Purpose of the Study

The purpose of this dissertation is to evaluate whether or not it is chronologically plausible to identify Bab edh-Dhra' and Numeira with two of the biblical "cities of the plain" from a conservative biblical perspective.

Justification of the Study

Although numerous scholars have entertained the possibility of a link between Bab edh-Dhra' and Numeira and the "cities of the plain" in Genesis, there has been no rigorous study to show whether or not such a link is chronologically possible from a biblical perspective. For his part, Schaub has been content to suggest that "Bab edh-Dhra' and Numeira may thus have generated the popular biblical traditions," without attempting to reconcile the dates at all (Schaub 1993: 130). Wood has simply noted that the date of the EB III–IV transition "is strictly an educated guess," although none of the dates he cites are compatible with his interpretation of the biblical events (Wood 1999: 78-9, n. 10). A study that addresses the chronological issues from a standpoint that also takes the biblical text seriously will provide a new perspective on this issue.

If it can be shown that the archaeological and biblical dates can be reasonably reconciled, the largest obstacle to identifying Bab edh-Dhra' and Numeira as candidates for the biblical cities of the plain will have been overcome, and further investigation into the compatibility of the biblical account with these Early Bronze Age cities would be warranted. There also may be implications for the absolute chronology of the Early Bronze Age if such an important link between text and tell is indicated.

If, on the other hand, it is shown that the chronological issue cannot be reasonably reconciled, biblical scholars should turn elsewhere in search of the cities of the plain,

either to a different archaeological period, a different geographical location, or to a different interpretation of the biblical text. Further excavation at Bab edh-Dhra' and Numeira would be of only secondary interest to biblical scholars.

Methodology

In broad terms, the method employed will be to establish the chronological parameters (range of possibilities) within which a comparison of archaeological and biblical data may take place, and then compare for overlap. This methodology follows the four steps outlined below.

Establish the EB III and IV Archaeological Context of Bab edh-Dhra' and Numeira

A solid understanding of the archaeological context of Bab edh-Dhra' and Numeira will form the foundation for the succeeding investigation. The entire occupational history of the sites will be reviewed, but the final occupational levels of the EB III will be of particular concern, since this was the last period in which there was any significant occupation of the walled city at Bab edh-Dhra' (Rast et al. 1980: 32) and the final period of occupation at Numeira (Coogan 1984: 75). This will be accomplished through a comprehensive review of the published material from Bab edh-Dhra' and Numeira that relates to those periods, along with any secondary literature that addresses the final destruction of the cities at the end of the EB III. The conclusions of the excavators concerning the relative date for this destruction will be reviewed and verified.

Establish the Range of Possible Absolute Dates for the End of the EB III

While the relative chronology of the Early Bronze Age is well established, the absolute chronology is much less certain. A fairly comprehensive review of the literature on the end of the EB III will be undertaken in order to establish the following: (1) the factors that are influential in establishing an absolute date, including archaeological stratigraphy, foreign synchronisms, and radiocarbon dating (Callaway and Weinstein 1977: 1); (2) the range of suggested dates for the end of the EB III; and (3) the certainty that can be attached to these dates. "Absolute" dates in this context refers to calendrical dates, as opposed to "relative" dates, which refers only to the order in which historical events occurred without reference to specific calendar dates.

Establish the Possible Chronologies for the Patriarchs

The third section will establish the chronological parameters within which the patriarchs lived, based in large part upon the data provided by the biblical text. A variety of reconstructions have been suggested by various scholars for how to calculate the dates of the patriarchs from the biblical data (Merrill 1980: 242; Kitchen and Mitchell 1980: 269; Hoerth 1998: 59). In this section I will review and summarize the major systems. The object is not to analyze which is best from an interpretational standpoint, but to establish the range of possible absolute dates for which a case can be plausibly made.

Analyze the Data for Possible Overlap; Summarize Results

Finally, the results of the first three sections will be analyzed to discern whether or not there may be a reasonable scenario under which Bab edh-Dhra' and Numeira may be viewed as contemporary with the biblical Abraham. The possible implications for biblical and archaeological chronology will also be reviewed.

Assumptions

Perhaps the primary assumption of this study is that the Genesis account is a reliable source of information for the time periods it purports to describe.² It is, in this sense, history. A grammatical/historical/literal hermeneutic will be employed in analyzing the biblical texts, which constitutes a secondary assumption. A less literal hermeneutic would allow for the Abrahamic account to be viewed as an etiological tale and would probably render this discussion pointless.

It is further assumed that the chronological framework established by Thiele is valid in its main points. Thiele's date for the beginning of the Israelite monarchy will function as the starting point for calculating the dates of the preceding biblical periods. Finally, it is assumed that the excavation reports from Bab edh-Dhra' and Numeira have followed protocol and are fair, accurate, and reliable records of what has been found.

² This aligns with the "epistemological openness" advocated by Provan, Long, and Longman (2003:48) and takes the biblical text seriously as a primary source.

CHAPTER 2

CHARACTER AND CHRONOLOGY OF BAB EDH-DHRA' AND NUMEIRA

The entire occupational history of the sites will be reviewed, but the final occupational levels of the EB III will be of particular concern, since this was the last period in which there was any significant occupation of the walled city at Bab edh-Dhra' and the final period of occupation at Numeira (Rast et al. 1980: 32; Coogan 1984: 75). This will be accomplished through a comprehensive review of the published material from Bab edh-Dhra' and Numeira that relates to those periods, along with any secondary literature that addresses the final destruction of the cities at the end of the EB III. The conclusions of the excavators concerning the relative date for this destruction will be reviewed and evaluated.

History of Exploration

Bab edh-Dhra' and Numeira are located along the southeastern shore of the Dead Sea (fig. 1). The site of Bab edh-Dhra' may have been visited as early as 1818, when Irby and Mangles noted bricks and pottery in this area. They identified the site with biblical Zoar. Lynch also recorded remains in this area, around 1850, and following the lead of

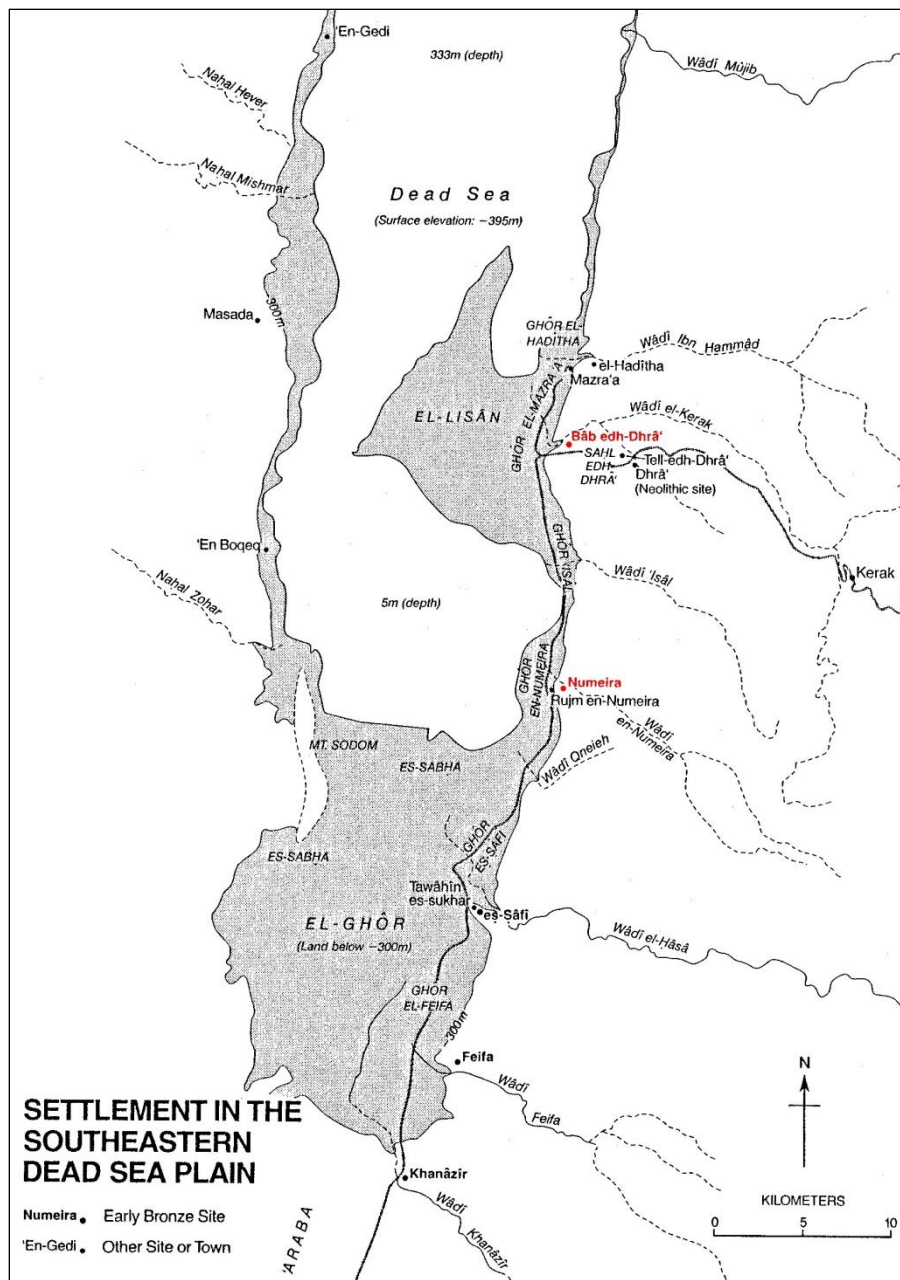

Fig. 1. Early Bronze sites in the southeastern Dead Sea plain (adapted from Schaub and Rast 1989: 14).

Irby and Mangles concluded that they were ancient Zoar. Likely the first discovery of Numeira should be attributed to Tristram, who recorded ruins there in 1872.³

Interest in this area was renewed in the 1920s, and in 1924 Albright, Kyle, and Mallon conducted a survey of the region. It was Mallon who first discovered occupational evidence at Bab edh-Dhra', noting a large number of flint artifacts, pottery, bits of bronze, tombs, and a fortress. He assigned the age of this "vast station" to the "Early Bronze period (circa 2600-2000 B.C.)," and considered it comparable to the earliest levels of Jericho, Taanach, Megiddo, and Gezer (Mallon 1924: 272, 275). At the same time, Mallon failed to recognize the existence here of a town and subsequently concluded that since no town remains had been found, the only remaining possibility for locating the Pentapolis in this area was to place the five towns in the southern basin of the Dead Sea (Mallon 1932: 54).

Kyle and Albright came to similar conclusions. The pottery of this "vast open-air settlement" and fortress was typical of the Early Bronze Age and the beginning of the Middle Bronze Age (Kyle and Albright 1924: 279), although certainly abandoned before the foundation of Jericho IV, roughly before the 18th century B.C. (Albright 1926: 61). Given the existence of six standing stones, or *massebôth*, at the site, they concluded that it was a cult site, "a kind of early Canaanite Gilgal" (1924: 278-9; also Albright 1926: 61). They also noted the existence of three streams in this area: Qurâhi (below es-Sâfi), Numeirah, and the 'Esâl, each of which could have supported a single town. These were

³ For an excellent overview of these early explorers, see Schaub and Rast 1989: 15-16. Other early travelers may have also visited these sites when they passed through the area, but none has left certain evidence.

thought to have supported the towns of Zoar, Sodom, and Gomorrah, with the locations Admah and Zeboiim left unidentified.

Lapp's excavations in 1965 were the first to show that Bab edh-Dhra' was actually a settlement rather than just a cemetery with an associated cult site. After the death of Lapp, these excavations were continued by Walter Rast and Thomas Schaub.

Although numerous early explorers had visited the general area of Numeira, including Glueck in 1934 (Rast 1987b: 47), the site was not recognized as an EB site until the survey of Rast and Schaub in 1973. Excavations were undertaken in 1977, 1979, and 1981. The Numeira excavations have not been officially published, but numerous individual articles have appeared (Rast et al. 1980, Rast 1981, Coogan 1984, Donahue 1984, Weinstein 1984, Schaub 1997b, Rast 2003).

Overview of Bab edh-Dhra'

Geographical Setting

Bab edh-Dhra' is located east of the Dead Sea where the Lisan peninsula connects to the eastern shore. Its elevation is -240 m below sea level, approximately 180 m above the waters of the Dead Sea. The area of the town site is about 12 acres (Rast 2003: 325).

The town sits on an alluvial plain that consists of material washed out in antiquity by the Wadi Kerak. This includes pre-Lisan gravel and sand, Lisan Marl, and in some of the higher areas crossbedded sand and gravel on top of the Lisan Marl (Donahue 1980: 47-50). The town site is located on the southern bank of the wadi. Geological investigation has shown that during the Early Bronze Age the bottom of the wadi, which is currently about 50 m below the town site, was about 28 m higher than it is now (Donahue 2003: 48). Erosional down-cutting during the intervening millennia has

significantly affected the site. Two tributary wadis have removed major portions of the occupational levels in the center of the town. Already by the Early Bronze Age II (EB II), erosion had become a factor within the town itself, forcing the inhabitants to build terraces in an effort to counter its effects (Rast and Schaub 2003a: 206; see fig. 2). The entire northern wall was eventually washed away, an event which may have happened already by the Early Bronze Age IV (EB IV) (Donahue 1980: 50). A drop in the level of the Dead Sea may also have been a contributing factor in the erosion of the wadi and its tributaries (Donahue 2003: 50).

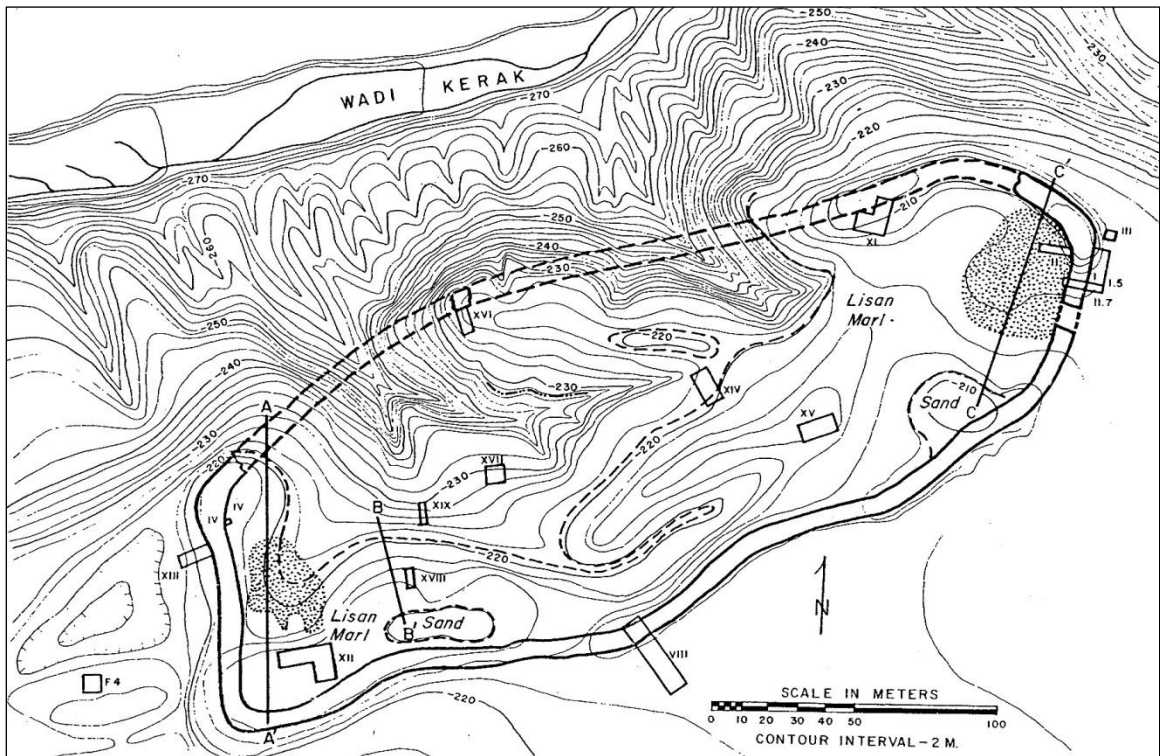

Fig. 2. Plan of the town site of Bab edh-Dhra' (after Donahue 1980).

Water supply for Bab edh-Dhra' may have come in part from the nearby Wadi Kerak, particularly if the wadi bed was significantly higher in antiquity. "Under these conditions, the ground water level in the area of Bab edh-Dhra' would have been higher.

It seems quite likely that the western tributary may have been initiated and eroded by a spring that was situated about 20 m. east of Field XVII. This spring may have been present prior to and during the occupation of the site" (Donahue 1980: 49). Donahue also estimates that optimum climatic conditions at Bab edh-Dhra' were probably reached during the EB II or III (2003: 55).

There are also some indicators of what the inhabitants of Bab edh-Dhra' ate. Among the faunal remains were not only donkey, camel, dog, cat, hyena, and rodent, but also gazelle and goat (Finnegan 1976). The most commonly encountered cultivated plant remains included barley, wheat, grapes, and figs (Rast et al. 1980).

Occupational History

Rast and Schaub summarize the occupational history of Bab edh-Dhra' as consisting of three major periods: an initial pre-urban settlement during the EB I, a lengthy urban settlement during the EB II and III, and a post-urban period in the EB IV (Rast and Schaub 1976: 2).

The earliest sign of occupation at Bab edh-Dhra' comes from the EB IA period, termed Stratum V by the excavators. Although no EB IA remains have been found at the town site, both shaft tombs and scattered remains of temporary dwellings (burn and refuse layers with scattered pottery) outside the town site led to the conclusion that the earliest occupants were pastoralists who buried their dead at Bab edh-Dhra' and probably grazed their flocks in the area (Rast and Schaub 2003a: 63). This population used a very elegant fine-ware pottery. The fact that similar pottery is not known from any other site suggests that they produced it themselves, a significant factor when considering the skills, culture, and values of these earliest inhabitants (2003a: 101).

It was during the EB IB that the town site was first inhabited in any discernible way. The early settlers of this time (Stratum IV) built mud-brick houses. The town had no defensive system yet, so the mud-brick houses are not restricted to areas within the later wall and in fact appear outside the town site, creating a village that was actually larger than the succeeding walled town. Seeds and plant remains, of which barley and wheat were most common (McCreery 2003: 452, table 14.1), indicate that agriculture was taking place. Most of the excavated occupational areas of the EB IB were topped with a thick ashy layer, indicating violent destruction.⁴ Tombs of this period included shaft tombs as well as circular charnel houses built of mud-brick.⁵ Significant parallels to the EB IB remains at Bab edh-Dhra' come especially from Arad (Stratum IV), 'Ai, and the Proto-Urban levels at Jericho, although good parallels also exist at numerous other sites.

It appears that the builders of the EB II town (Stratum III) were the first to construct a city wall, although most remains of the wall appear to have been removed by the construction of the later, larger EB III wall. Another innovation at this time was the construction of a sanctuary on the second-highest spot within the town site. In contrast to the regular mud-brick buildings, the sanctuary was built of small stones, the walls were plastered, and the ceiling was supported by five pillars. Mortuary practices also changed during the EB II. New rectangular charnel houses became dominant, an innovation that

⁴ Rast and Schaub point to numerous other EB I sites that also ended with a burning destruction, including at least the southern Ghor and the Jordan valley (2003: 130-31).

⁵ An example of the circular charnel house of this period is tomb A 53, excavated by Lapp; shaft tombs include A 43, A 45, and A 47 in Cemetery A (Schaub and Rast 1989: 208, 226).

continued in the EB III city.⁶ The pottery of this period continues some of the previous traditions and has parallels at numerous other EB II sites.⁷ For the first time a type of pottery is present that is also found in Egypt, the Red-Polished Ware ("Abydos" Ware). Amiran considers this ware to have likely originated in southern Canaan and to have found its way to Egypt by way of export of goods, probably various kinds of oil (1969: 66; fig. 3). However, the absence of other typical wares indicates that Bab edh-Dhra' was not a major player in international trade (Rast and Schaub 2003a: 246).⁸ Bab edh-Dhra' reached its zenith during the EB III (Stratum II), with an estimated population of about 1,000 people (Rast 2003: 326). A massive new city wall with towers and a gate was

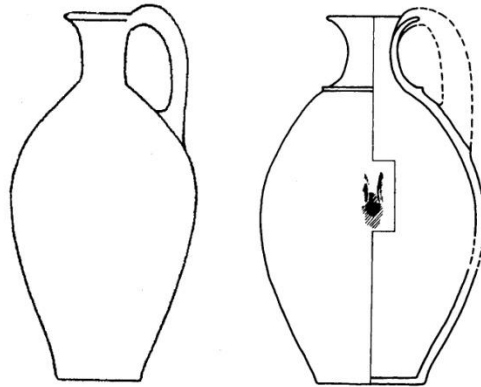

Fig. 3. Abydos jars: *l* from Tel el-Far'ah North (Amiran 1969: 65 pl. 17.3), *r* from Bab edh-Dhra' (Rast and Schaub 2003b: 77, pl. 38:19-24).

⁶ One round charnel house from early in the EB II period (Tomb A 56) underlines the continuity between the EB IB and EB II populations (Rast 2003: 325).

⁷ Rast and Schaub compare Jericho, Tell Um Hammad, Pella, Tell el-Far'ah north, 'Ai, Yarmuth, and Arad, among others (2003a: 246).

⁸ The connection with Egypt is examined by Stager (1992: 37-39).

built.⁹ The sanctuary was rebuilt. Areas within the city wall that had previously been vacant were filled. Housing grew beyond the confines of the city itself, spreading out on all sides except the steep northern side. The rectangular charnel houses that first appeared in the EB II continued to be the preferred burial method, and several new charnel houses of this type were built during the EB III.¹⁰ Pottery from this period is once again very comparable to that discovered at other EB III sites, with a few distinguishing characteristics.¹¹

After the destruction of the EB III town, the site was once again settled, although in a very different way. The majority of the town itself was seriously ruined, and the structures of the old town were left to stand unused. The exception was the cult site, located on a rise in the eastern section of the town. This area was rebuilt and used once again as a cult site. For the most part, the remainder of the EB IV (Stratum I) occupation occurred in the form of scattered mud-brick houses outside the old city walls. One EB IV house in Field XVI was built on top of a section of the EB III northern city wall (Rast et al. 1980: 32). This gives some indication of the magnitude of the city's destruction at the end of the EB III. Rast and Schaub estimate that the time lapse between the end of the EB III and EB IV was not long, although the question of whether the EB IV inhabitants were related to their EB III predecessors remains unanswered. On the one hand, there is

⁹ The wall was constructed with a foundation of field stones topped by mud-brick. An eastern tower may have been unconnected to the city wall, possibly a stop-gap measure as the northern city wall was lost to erosion. The western gate was preserved to a considerable height and was found to have been blocked up in antiquity (Rast and Schaub 2003a: 263; 268ff.).

¹⁰ Newly established tombs include A20 and A8, while those that continued from the EB II into the EB III include A44, A41, A21, and A51. It is also apparent that all the charnel houses still in use at the end of the EB III were subject to burning when the final EB III town was destroyed. See the chart in Schaub and Rast 2003: 31, table 2.

¹¹ The most cited parallels are Jericho, 'Ai, and Tel Yarmuth (Rast and Schaub 2003a: 393ff.).

the continued use of the cult site, some continuation in the ceramic tradition, and it appears that some of the charnel houses may have seen additional use in the EB IV, despite their destruction at the end of the EB III. On the other hand, the pottery also shows striking differences from the previous tradition "in practically every ware-attribute category," hinting at least at the possibility that the EB IV inhabitants were not natives to the area. The excavators prefer, however, the view that the Stratum I inhabitants were a remnant of the Stratum II town (Johnston and Schaub 1976: 35; Rast and Schaub 2003a: 448; for similar conclusions regarding EB III/IV in general, see Long 2003). The best ceramic parallels for Stratum I come from Aro'er and Khirbet Iskander, both on the Jordanian Plateau (Rast and Schaub 2003a: 446; see fig. 4).

Final Destruction and Abandonment

The final destruction of Bab edh-Dhra' poses an interesting problem. In one sense it could be said that the final destruction occurred at the end of the EB III, although the site was not abandoned for good until sometime in the EB IV. Both Bab edh-Dhra' and her sister city Numeira (see below) were violently destroyed at the end of the EB III.

Geologic investigation has shown that the EB IV occupants faced two problems in attempting to resettle the site. One was fault movement and uplift of the area, resulting in the degradation or active erosion of the town site and probably the loss of the north wall of the city. The other would have been the decrease or even complete loss of spring activity at the site, due to the same fault movement, the down-cutting of the wadi bed, and the subsequent lowering of the water table (Donahue 1980: 50).

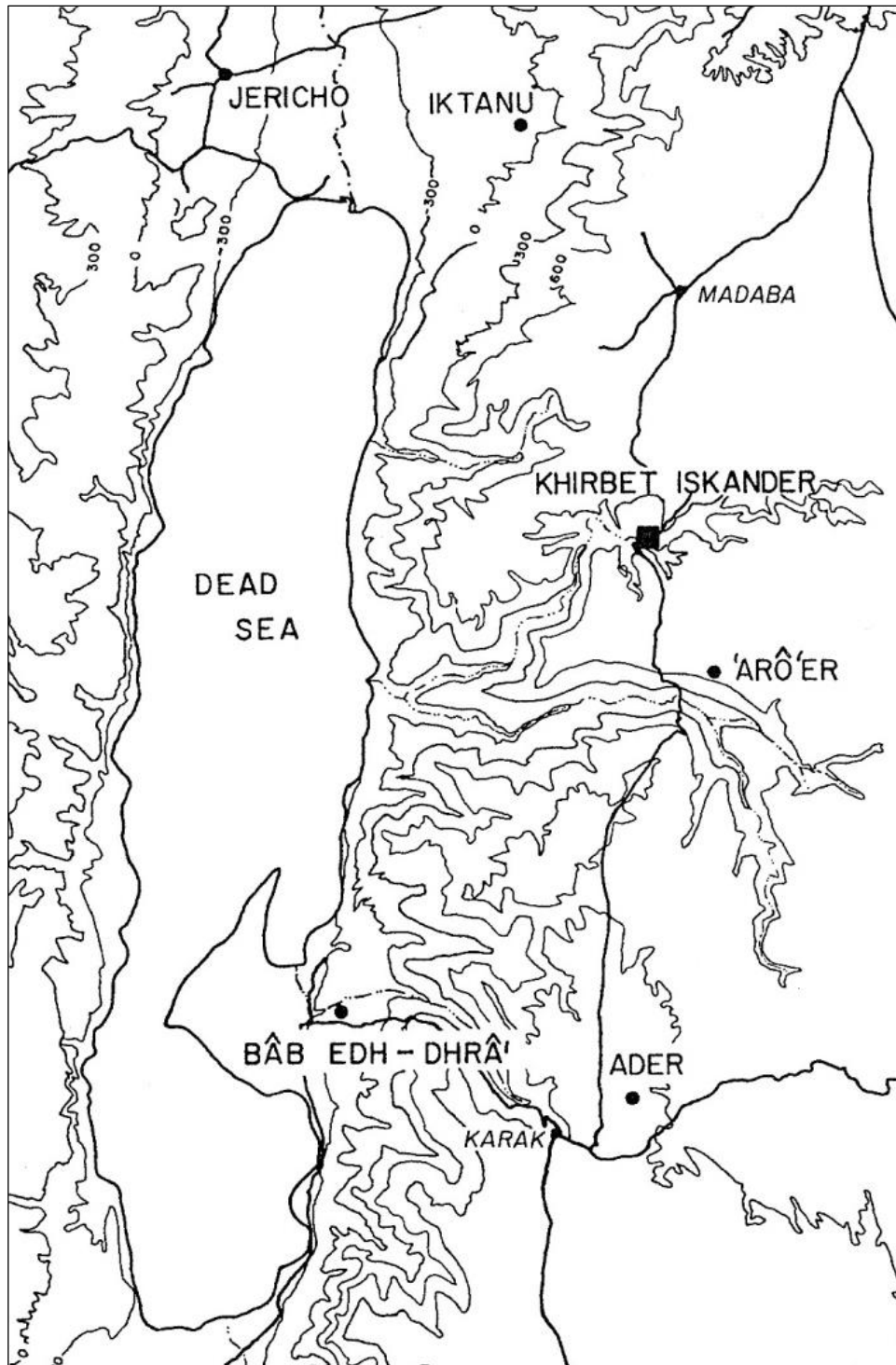

Fig. 4. Map showing the location of the EB IV sites of 'Aro'er and Khibbet Iskander, in relation to Bab edh-Dhra'; adapted from Long (2003: 10).

Overview of Numeira

Geographical Setting

Numeira is located approximately 13 km south of Bab edh-Dhra'. A little more than a hectare in size, it is situated on an alluvial spur that juts westward from the Transjordanian hills. A slight saddle separates the site from the higher ground to the east. The Wadi Numeira passes along the north side of the town (fig. 5). As with Bab edh-Dhra', the wadi has deepened significantly since the last Early Bronze Age occupation. The drop from the town site to the wadi bed is now some 48 m, but Donahue has shown that in antiquity the stream flowed just to the east of the site, across the saddle, and thus provided a convenient water source (1984: 87). It is estimated that as much as half of the

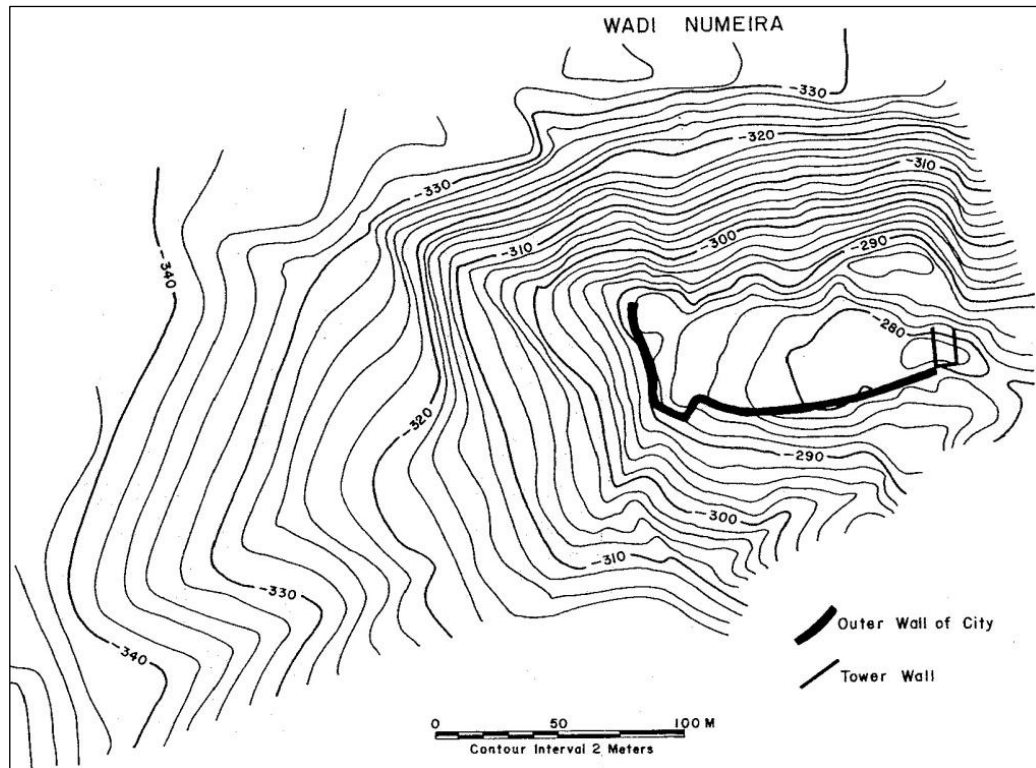

Fig. 5. Map of Numeira (after Donahue 1984: 86).

original area of the town has been washed away by the erosion of the wadi on its northern side, due—as with Bab edh-Dhra'—to fault movements along the Dead Sea (Donahue 1984: 88).

Occupational History

Numeira was founded as a new settlement during the EB III, apparently an expansion of the burgeoning population at Bab edh-Dhra'.¹² It may well have been set up with the purpose of supplying grain for the inhabitants of Bab edh-Dhra'. Petrographic analysis shows that some of the pots in EB III charnel houses at Bab edh-Dhra' were made of clay from Numeira, an indication that the inhabitants of Numeira were taken back to be buried in the Bab edh-Dhra' cemetery (Rast and Schaub 2003a: 251; Rast 2003: 326).

Numeira was completely walled, with a tower located on the saddle at the eastern end of the hill, the area that would have been most vulnerable to attack. The town wall was built in longitudinal sections and was approximately 4 m thick, making it a substantial defensive tool. Excavation did not allow certain determination of the character of the wall. The preserved portions were sandstone boulders, and heavy boulder debris is strewn down the hillside, especially to the south. It is possible, although not deemed likely, that the top of the wall was mud-brick as at Bab edh-Dhra', and some mud-brick debris was found within the town site and the east tower (Rast 1981; Coogan 1984: 80).

¹² Final publication of the excavations at Numeira have not been completed at the time of this writing, thus the descriptions given in this section are based on preliminary reports.

Both whole and restorable pottery were found in the houses at Numeira, all of them indicating that the site was established, destroyed, and abandoned during the EB III. Rast concluded that "the time span during which the city was in existence seems not to have covered more than a century" (Rast 1981: 42; 2003: 327).

Final Destruction and Abandonment

Even before excavation began it was clear that Numeira had suffered a fiery destruction toward the end of the EB III. The ashy debris from this destruction reaches a depth of 1.5 m in some places (Rast 1981: 36). Subsequent excavations revealed an earlier destruction as well. The existence of more than 20 layers of chaff and carbonized material between the two destructions may indicate seasonal activity, thus allowing the estimate that there was about a quarter century between the two destructions (Coogan 1984: 80; Wood 2007: 83, n. 6). A skeleton of a mature male was found in the earlier destruction debris of the tower, and two were found in the debris of the later destruction (Coogan 1984: 79, 80). Based on the absence of small finds and on the apparent blocking of some doorways, Coogan hypothesizes that the inhabitants may have fled the city before an impending earthquake.¹³ The site was not re-settled after the second EB III destruction.

¹³ Coogan's explanation is highly unlikely. Even today scientists are unable to tell in advance when an earthquake is coming. Furthermore, his hypothesis does not explain either the fiery destruction or the lack of rebuilding. If the inhabitants *had* known that an earthquake was coming, with sufficient time to block up doorways, surely they would have extinguished any fires within the town.

Chronological Indicators for Bab edh-Dhra' and Numeira

Relative Chronology

EB I

The EB IA remains at Bab edh-Dhra' appear to be regionally distinct. Some of the forms that are common here (punctuate decoration and raised slashed bands around bowls and necked jars) are rare or unknown elsewhere, and many of the most common forms found elsewhere are not found here, although some parallels (thumb-indented ledge handles, hemispherical bowls, some use of slip and burnish) can be found in common. Rast and Schaub consider the closest parallel to be the EB IA culture from Hartuv in southern Israel, as well as Tell Halif Stratum IV (2003: 99). More helpful is the observation that the EB IA culture at Bab edh-Dhra' is closely related to the following EB IB, which does have clear correlations with southern and central Palestine.

The pottery of the Early Bronze Age I (EB I) at Bab edh-Dhra' may be divided into four main families: Fine Ware, Plain Ware, Carinated Ware, and Line Group Ware. The Line Group Ware (LGW) is clearly later in the EB I than the other families, and it is a ceramic type that is found widely during the EB I on both sides of the Jordan (Schaub and Rast 1989: 271-3). Stager, referring to this type as Line-Group Painted Ware (LGPW), agrees in placing it at the end of the EB I and notes that it appears shortly after ceramics and lithics typical of the Gerzean period in Egypt (1992: 29).¹⁴ Schaub and Rast suggest a ceramic development from Fine Ware to Plain Ware to Line Group Ware, with the Carinated Ware overlapping the Fine Ware and Plain Ware groups (1989: 273;

¹⁴ The specific site mentioned by Stager is Wadi Ghazzeh Site H, where Gerzean ceramics are found with EB I Grey-Burnished Ware, Red-Burnished Ware, and Impressed-Slashed Ware (1992: 29).

see fig. 6). Significant parallels to the EB IB remains at Bab edh-Dhra' come especially from Arad (Stratum IV), 'Ai, and the Proto-Urban levels at Jericho, although good parallels also exist at numerous other sites.

EB II

The pottery of the EB II levels continues some of the previous traditions and has parallels at numerous other EB II sites.¹⁵ "The closer the site to Bab edh-Dhra' the more extensive are the parallels. 'Ai and Yarmuth have at least 16 of the same type vessels and Arad has 33" (Rast and Schaub 2003a: 246). These include holemouth jars, holemouth bowls, necked jars, deep bowls, wide shallow bowls, and platter bowls, with distinctive rim shapes (fig. 7). For the first time a type of pottery is present that is also found in Egypt, Red-Polished Ware, also known as "Abydos" Ware. In Egypt, Red-Polished Ware appears in Dynasty 1 contexts (Amiran 1969: 59-66; Stager 1992: 35). Amiran considers this ware to have likely originated in southern Canaan and to have found its way to Egypt by way of export, probably of various kinds of oil (see fig. 3).

At the same time, the absence of other typical EB II wares indicates that Bab edh-Dhra' was not a major player in international trade (Rast and Schaub 2003a: 246).¹⁶ Missing are three of Stager's categories of "foreign ware" (Deep-grooved lattice-burnished ware, EB II Painted Ware, and Metallic Combed Ware), as well as more domestic forms such as globular round-base cooking pots and the application of plastic bands on holemouth jars and kraters (Rast and Schaub 2003a: 246).

¹⁵ Rast and Schaub compare Jericho, Tell Um Hammad, Pella, Tell el-Far'ah north, 'Ai Phases III-V, Yarmuth, and Arad Stratum III-I, among others (2003a: 246).

¹⁶ The connection with Egypt is examined by Stager (1992: 37-39).

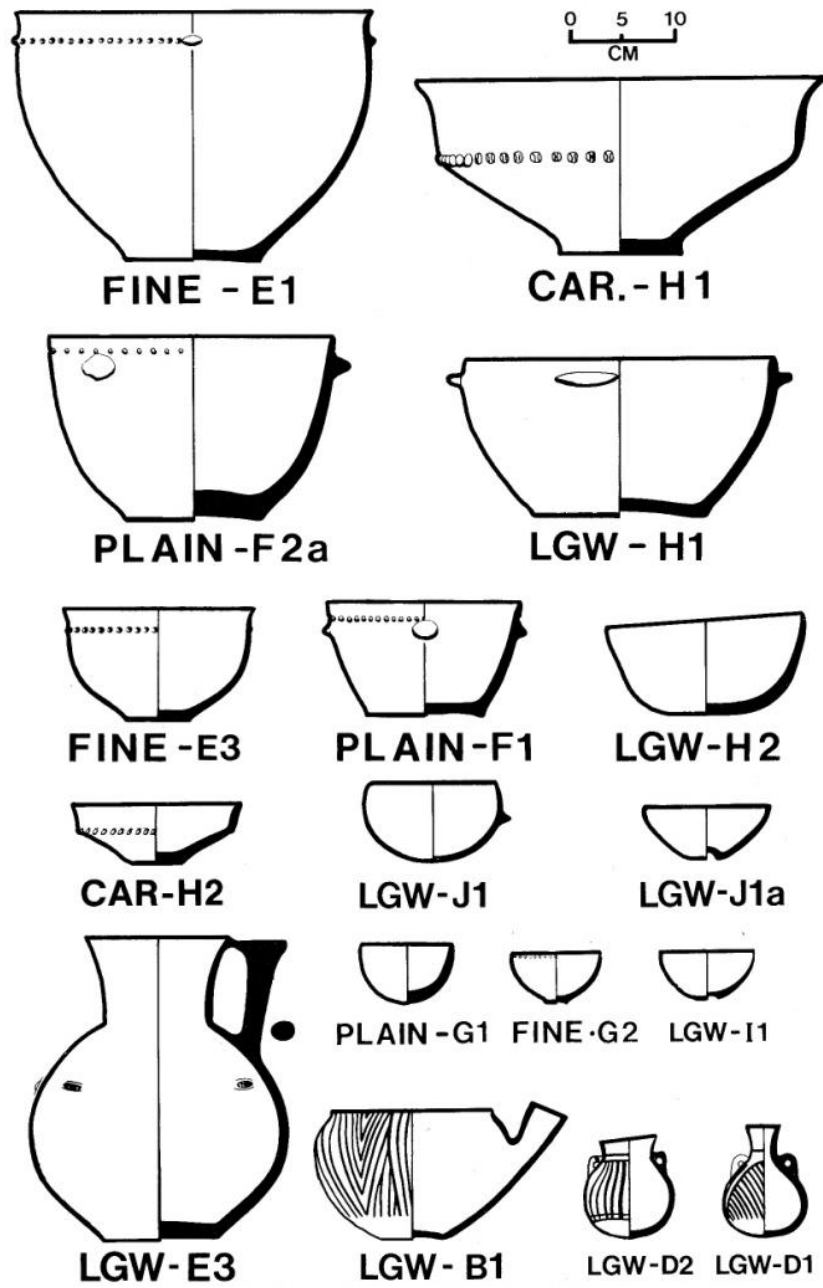

Fig. 6. Major forms of the Early Bronze I at Bab edh-Dhra' (after Rast and Schaub 2003a: 267).

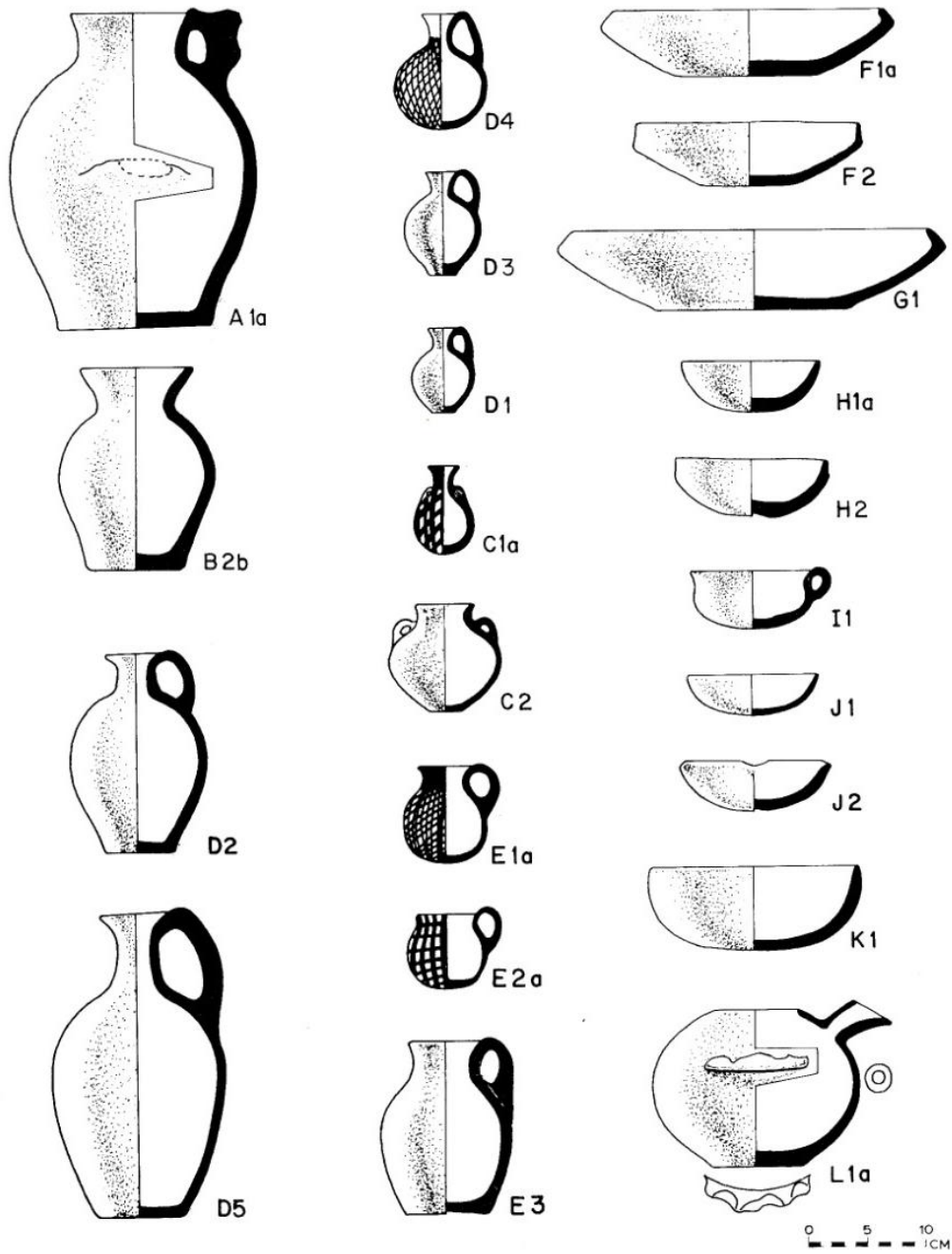

Fig. 7. Major forms of the Early Bronze II at Bab edh-Dhra' (after Rast and Schaub 2003a: 431).

EB III

Pottery from the EB III at Bab edh-Dhra' shows strong continuity with the preceding EB II traditions. Rast and Schaub (2003a: 356) note that

standardization has taken hold in the preparation of clays and in basic forms and sizes and in many of the specific types. There is consistent use in both strata of particular tempers for a distinctive range of vessels. For most of the basic form groups, the average size and capacity of the pots is similar. Variations in form of rim types in holemouth jars and wide, shallow bowls are consistently the same. Similarity in cores suggests continuity in firing practices.

The EB III pottery is also very comparable to that discovered at other EB III sites, with a few distinguishing characteristics (fig. 8). The broad, mold-shaped platters that are common in EB III levels at Tell Yarmuth seem to be lacking at Bab edh-Dhra', but numerous forms are found at both sites, including necked jars, platter bowls, holemouth jars, vats, deep bowls, and small bowls. Many close parallels can also be cited from Jericho's EB III levels, during a time that also bears the first appearance of imitation Khirbet Kerak ware, an imported ware that is diagnostic of the EB III, although it has recently been argued that Khirbet Kerak ware appears already at the end of EB II (Yekutieli 2009: 232).¹⁷ In fact, one imitation Khirbet Kerak ware bowl was recovered from Charnel House C 4 (Schaub and Rast 1989: 388, fig. 245: 20).¹⁸ The parallels most cited by Rast and Schaub for EB III pottery are Jericho, 'Ai, and Tel Yarmuth (2003a: 393ff.).

¹⁷ Amiran (1969: 68) and Stager agree that Khirbet Kerak ware is the most diagnostic feature for the beginning of the EB III. However, this ware appears almost exclusively in the north, leading Stager to the statement that its absence in southern Palestine, the Negev, and the Sinai "makes it extremely difficult to gauge when EB II ends and EB III begins" (1992: 36).

¹⁸ Charnel House C 4 is considered by Schaub and Rast to be EB II-III.

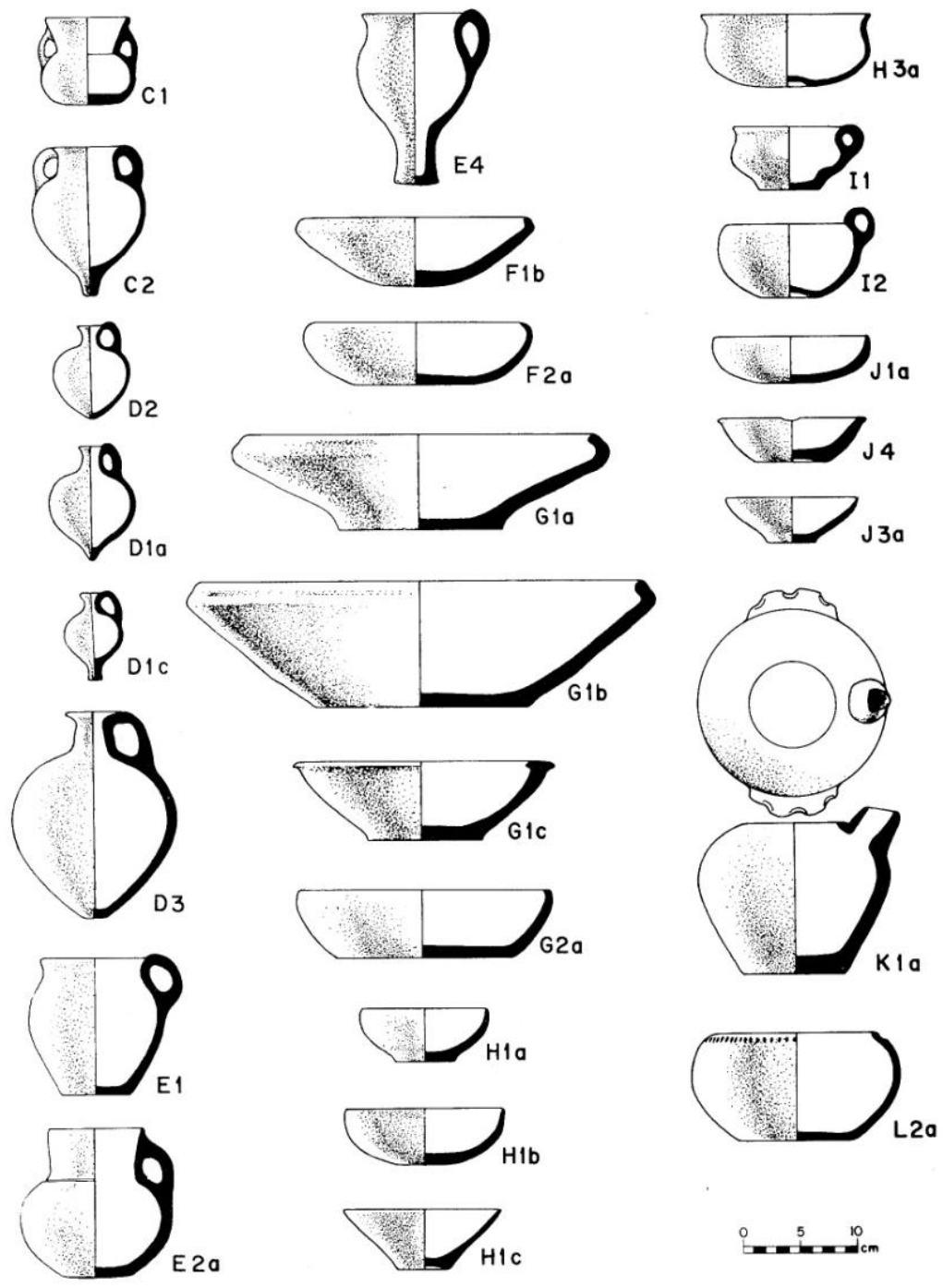

Fig. 8. Major forms of the Early Bronze III at Bab edh-Dhra' (after Rast and Schaub 2003a: 437).

Rast and Schaub also recovered from Tomb A 22 a round-based jar with sharply flaring flange rim that is comparable to items known from Old Kingdom (OK, Third to Sixth Dynasties) Egypt (1980b: 39, fig. 11:3; see fig. 9).

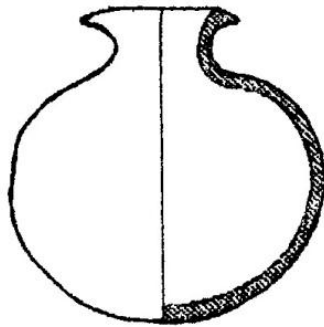

Fig. 9. Flared-rim pot (EB III) from Bab edh-Dhra' (adapted from Rast et al. 1980: 35, fig. 11.3).

A black steatite (chlorite) cylinder seal recovered from an EB III balk at Bab edh-Dhra' appears to originate in First Dynasty Egypt (fig. 10). The connection with the Egyptian First Dynasty, which is much more strongly linked with the EB II, may be explained by an allowance for transport time and the "heirloom factor" (N. Lapp 2003: 549).¹⁹

EB IV

EB IV pottery from Bab edh-Dhra' shows both continuity with the previous EB II-III types and distinctive new types. Rast and Schaub describe how in "practically every

¹⁹ Three cylinder seals were found, all in EB III contexts. Made of fired clay, pink alabaster, and black steatite, the latter two are considered to be imported from Egypt. Lapp concludes that the black steatite (chlorite) seal was imported as-is from Egypt, while in the case of the alabaster seal perhaps only the raw material was imported (N. Lapp 2003: 551).



Fig. 10. Steatite seal and impression (Rast and Schaub 2003: CD-ROM).

ware-attribute category—temper, ware fabrics, ware color, and surface treatment—there are significant variations from the established patterns of the wares of Stratum III-II. Different patterns are also noticeable in the size ranges of vessels and distribution of basic forms" (2003a: 423). These differences, however, should not be construed as a complete break with the previous population, since shared traits in forms like wide, shallow bowls, holemouth jars, and lamps "show continuity in both form and type," indicating "an uninterrupted sequence of population from late EB III into EB IV at Bab edh-Dhra'" (2003a: 448; cf. Richardson 2003: 294, Long 2003: 308).

Although most of the pottery continues the earlier tradition of being hand-made, some pieces show evidence that at least the neck was turned on a wheel (Schaub 1973: 11). Combed, four-spouted rim jugs, along with the four-spouted lamps of this period that they may have inspired, are new forms, as are the flat-based, rilled-rim "teapots" and bowls, thin rim bowls, and knobbed, handleless jars (fig. 11).

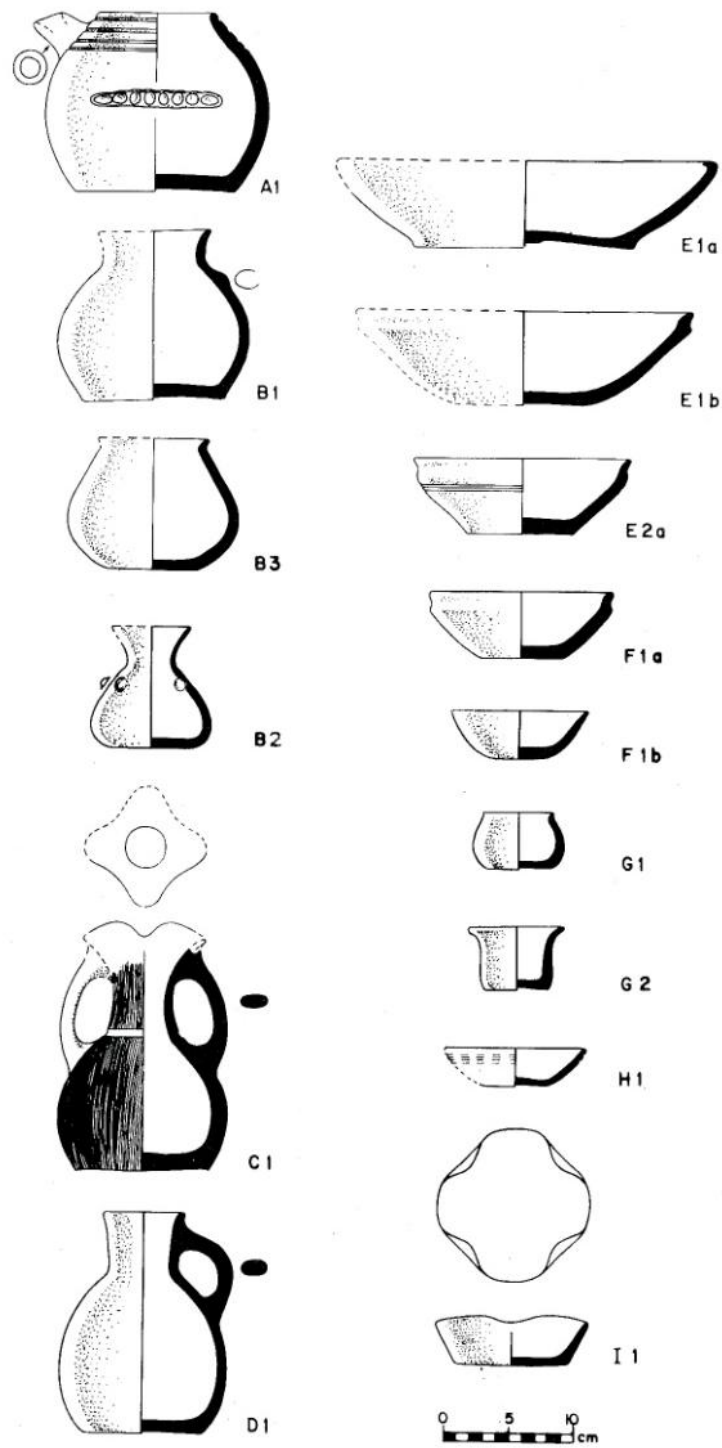

Fig. 11. Major forms of the Early Bronze IV at Bab edh-Dhra' (after Rast and Schaub 2003a: 499).

The best ceramic parallels for Stratum I (EB IV) come from Aro'er Phase VI and Khirbet Iskander Phase 1-3, both on the Jordanian Plateau. The wide, shallow bowls from Bab edh-Dhra' find exact parallels in size, form, and ware to those found at Aro'er; and Stratum I holemouth jars, teapots, tall-necked jars, deep bowls, carinated cyma-shaped bowls with everted rims, small necked jars, small closed-form jars, small shallow bowls, votive cups, and wide shallow bowls have excellent parallels at Khirbet Iskander. Other parallels are to be found with materials from Tell Iktanu Phase 1, Tell Um Hammad Stage 5, and Khirbet Hamra Ifdan Phase 6 (Rast and Schaub 2003a: 446f.).

Schaub has also pointed out three possible Egyptian parallels to pots recovered from the EB IV tomb A 54. The first is a set of three "thin rim bowls" from this tomb that are "quite similar" to Egyptian diorite bowls from the end of the Sixth Dynasty (fig. 12).²⁰ The second is a cup with straight sides and flaring wall, which "may well be

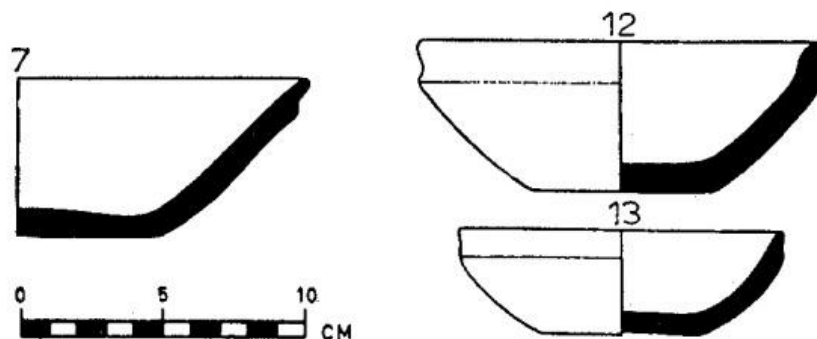

Fig. 12. Thin-rim bowls from EB IV Tomb A 54 at Bab edh-Dhra' (adapted from Schaub 1973: 8; fig. 6:7, 12, 13).

²⁰ Although Schaub associates these bowls with Dyn VI, he does qualify this in a footnote. "The bowl with recurved rim dates from the IV to the VI dynasty at Giza (it has an earlier and longer life at other sites) but the forms with flat base belong to the later stages. . . . A domestic use of this bowl, ladies cosmetics, is represented on a scene from the sarcophagus of Kensit, XIth dynasty" (Schaub 1973: 16, n. 40).

related" to the Sixth Dynasty votive bowls (fig. 13). These connections seem to be reaffirmed in the final publication of the tomb (Schaub and Rast 1989: 482).

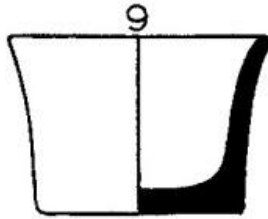

Fig. 13. Votive bowl (?) from EB IV Tomb A 54 at Bab edh-Dhra' (adapted from Schaub 1973: 8; fig. 6:9).

Finally, Schaub has noted the connection between the combed decoration on large storage jars of this period and wares imported into Egypt during the Fourth to Sixth Dynasties, which Albright ultimately traced back to Phoenicia (Schaub 1973: 14; see fig. 14). Although the only whole vessels were found in the tombs, evidence of similar jars

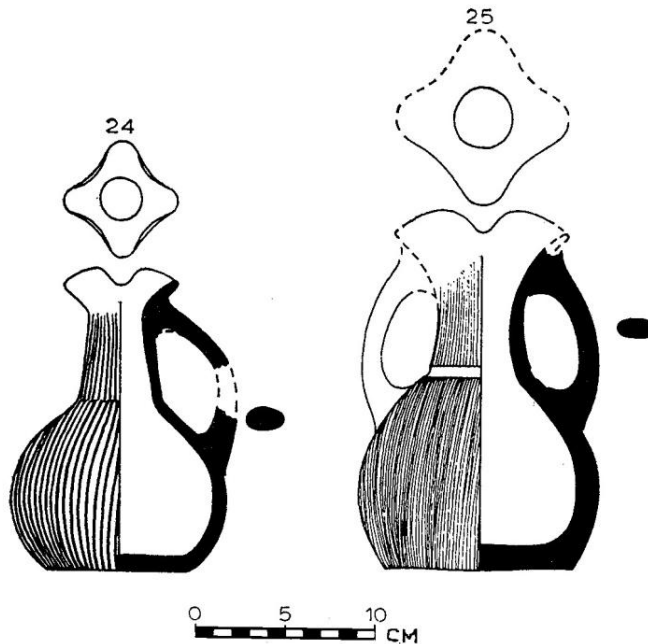

Fig. 14. Combed, handled jars from EB IV Tomb A 54 at Bab edh-Dhra' (adapted from Schaub 1973: 10; fig. 8:24-25).

were also found in Stratum I (EB IV) of the town site (Rast and Schaub 2003a: 444). Although this last match is rather broad, it fits with the other Egyptian parallels. It should be noted that tomb A 54 is on the early end of the EB IV, even described as the "missing link" between EB III and EB IV, although Schaub and Rast do place it in the EB IV (Schaub and Rast 1989: 490). Also, both tombs A 52 and A 54 are associated with the latest phases at Bab edh-Dhra', indicating that occupation at the site did not last long into the EB IV (Schaub and Rast 1989: 501).

Summary

In summary, there seems little reason to doubt that the relative chronology of the Early Bronze Age strata at Bab edh-Dhra' and Numeira has been correctly fixed. Sufficient pottery has been recovered, including diagnostic forms and regional parallels, to establish a strong relationship with other sites. In some cases, specifically the EB IB, EB II, and EB IV, there are wares that may be connected with Egypt.

Absolute Chronology

Radiocarbon Determinations

A total of 21 radiocarbon dates from Bab edh-Dhra' and Numeira have been published. Thirteen were published by Weinstein in 1984, and an additional set of eight was published by Weinstein in 2003 (fig. 15).

One main conclusion can be drawn from the radiocarbon dates. That is, radiocarbon is of very little assistance in determining the absolute chronology of the sites. This conclusion is based on the following observations.

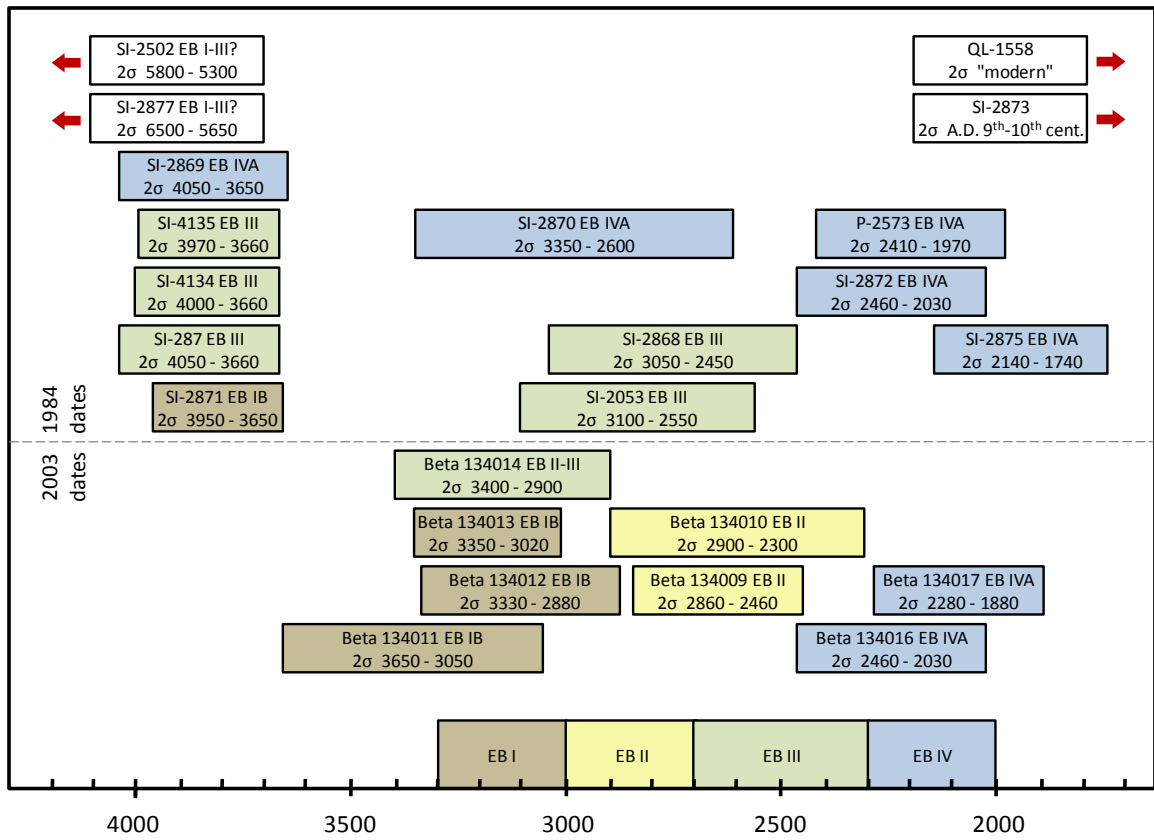

Fig. 15. Radiocarbon dates from Bab edh-Dhra' and Numeira plotted against the historical periods they represent. For descriptions of the various samples, see Weinstein (1984, 2003).

The radiocarbon dates cover much broader timespans than any archaeologist or historian would be willing to consider for these periods. For example, the EB IB dates cover more than 1,000 years, the EB III more than 1,500 years, and the EB IV more than 2,300 years. These numbers contradict every other known indicator of how long these periods lasted. There simply is not enough material present to account for occupation of these sites for that length of time.

These radiocarbon dates are not even capable of positioning the levels in the correct order. If these dates are taken at face value, one would conclude that the EB III preceded the EB I-II, and that the EB IV was contemporaneous with all the others. That conclusion would be patently false, based solely on the order of the superimposed strata at the site. There is no question that the EB III town came after the EB II town, as its houses and walls were built over the EB II remains. Yet the radiocarbon dates from the city would reverse that order, resulting in the EB III city being older than the EB II remains over which they were built.

There are clearly numerous "outliers" in these two data sets. This is not a completely unexpected result in a scientific method that is based on counting statistics. However, the number and extremes in this case are surprising. The 1984 results included two EB III assays that were in the sixth and seventh millennia B.C. Such results are not off by decades, or even centuries, but by four to five millennia. The 1984 results also included two assays that were equally extreme in the other direction, a reading in the ninth to tenth centuries A.D. and a "modern" reading. The radiocarbon scientists were quick to dismiss such readings as obviously erroneous and not worthy of further discussion. Weinstein concluded that only four out of the eight most recent dates "may

have real value” (Weinstein 2003: 648). It might be worth pondering, though, how such results could have been attained. Presumably the materials chosen in the field came from places that appeared to be uncontaminated, and presumably they were retrieved and transported with some effort to avoid contamination, and presumably the radiocarbon lab did not find anything questionable about the samples when they were submitted for testing. If, then, the only indicator that something is amiss is the resultant date, how can we know that the samples that do match the expected dates are not merely accidental?

The EB IV dates cover a timespan that includes all of the others. If the four extremely early and late dates are excluded, the EB IV dates then provide both the earliest and the latest dates in the entire sequence (4050–1740). The only way to avoid the conclusion that the EB IV was contemporaneous with all the rest of the EB I-III is to disregard more radiocarbon dates.

In fact, this is exactly what Weinstein himself has done. He rejected at least half of the dates as spurious. Regarding the eight most recently published dates, his conclusion was that "as few as two of the EB IB dates and the two EB IVA dates may have real value for the chronology of Bab edh-Dhra' in the Early Bronze Age" (2003: 648). That amounts to exactly 50% of the radiocarbon dates that must be rejected. Discarding half of the data is an astonishing move, yet it appears necessary. At this point it becomes clear that those results which are accepted are accepted not on the basis of their ability to independently date the materials or because of any inherent quality, but simply because they happen to agree with (or at least overlap) the dates previously assigned to these sites based on other data. What is the "real value" that is claimed for

half of these readings? Their "real value" is nothing more than the fact that they happen to coincide with the dates already assigned to the sites.

Given these results, it could hardly be more clear that the radiocarbon dates produced from Bab edh-Dhra' and Numeira are really quite worthless for purposes of absolute chronology. Although a few of them happen to overlap the expected periods, this appears to be as much a product of chance as anything. We must turn elsewhere in our attempt to establish a possible absolute date for the end of Bab edh-Dhra' and Numeira.

Historical Synchronizations

The other possibility for getting at absolute dates for the end of the EB III at Bab edh-Dhra' and Numeira is through synchronization with other EB III sites that can be dated through historical means. The difficulty in this case is that the material remains that would be most useful for such synchronizations—imported ceramics—are lacking at our sites for the EB III. Two possibilities remain.

The first possibility would be to find earlier or later period synchronizations (e.g., EB II or EB IV) and estimate the amount of time that lapsed between the two periods. In the case of Numeira this is not possible, as the site was only occupied during the EB III. For Bab edh-Dhra', however, this would theoretically be possible.

In practice, we find marginal assistance from the EB IV because only wares with general similarities to foreign types are found. The similarities are important, but they are not as direct as a specifically imported ware, nor can they be tied to a very narrow time range. As Weinstein (2003: 646) has noted, "there are no archaeologically or

historically fixed links between Palestine and the Nile Valley during this period to let us date the early EB IV period with any precision."

The EB I and II hold out slightly more possibility with the EB I Line Group Painted Ware and the EB II Abydos Ware, but again there are weaknesses. As with the EB IV, the ceramic parallels are general in nature, not precise. Also, as we move further back in time the Egyptian absolute chronology becomes less well defined, making the synchronisms even broader in scope, possibly spanning centuries. Finally, it is not possible to estimate the length of the EB III itself with much certainty, even if a fixed start date could be established. It may be possible to suggest a date within a couple of centuries based on EB II synchronizations, but such a broad, general estimation would not provide the specificity needed to be helpful in this problem.

The second possibility for synchronization would be to correlate the end of the EB III at Bab edh-Dhra' and Numeira with the same period at other sites in the Levant that do have imported wares and that can be more directly synchronized to Egypt or Mesopotamia. In essence, this approach would amount to determining a date for the end of the EB III in the Levant in general and then applying that to Bab edh-Dhra' and Numeira specifically. The underlying assumption, of course, must be that the EB III came to an end at generally the same time in all these places. This is almost certainly true in a broad sense, but it is impossible at this point to say with any specificity how closely the end of the EB III at one place matched the same at another place. At any rate, this approach may be more promising than other approaches, and will be the focus of the next chapter.

CHAPTER 3

ABSOLUTE CHRONOLOGY FOR THE EARLY BRONZE AGE III–IV TRANSITION IN THE LEVANT

There are two major sources of data that can be used for estimating absolute (i.e., calendar) dates for the Early Bronze Age in the Levant. First, there are numerous synchronisms between the Early Bronze Age sites in the Levant and those in neighboring Egypt and Mesopotamia. Because written records in Egypt and Mesopotamia go back much further than they do in the Levant, it is possible to estimate their absolute chronologies with more precision. Linking those periods with parallel periods in the Levant should then provide something of an absolute date for the latter. This would be dependent, of course, on both the strength of the synchronism and on the certainty of the Mesopotamian or Egyptian dates.

The second possibility for estimating absolute dates for the Early Bronze Age Levant is radiocarbon dating. Numerous samples from a variety of Early Bronze sites and periods have been ^{14}C dated. In theory ^{14}C can provide an accurate set of dates completely independent of other dating systems. In reality, however, it is a complex method built on a number of assumptions, it is subject to the vagaries of field collection and multiple possible sources of contamination, and in the end it produces only date estimates that are statistically probable, not absolute.

Although they tend to pull in different directions, and despite their inherent weaknesses, foreign synchronisms and ^{14}C dates are the strongest sources currently available for estimating the absolute dates of the Early Bronze Age. Thus they will be investigated as the key resources for estimating the date of the EB III–EB IV transition in the Levant.

Foreign Synchronisms

Mesopotamian Chronology

Our knowledge of Mesopotamian history and chronology, like that of nearly all civilizations, is better in later periods than in earlier ones. Dates for the first millennium are based on the occurrence of a total solar eclipse during the eponymy of Bur-Sagale, June 15, 763 B.C. (Kitchen 1991: 204). Older written records such as king lists, eponym lists, and the eponym chronicle allow the reckoning of dates that are precise within two decades back to the reign of the Kassite king Kadašman-Enlil I in about 1400.

The events of the first half of the second millennium B.C. are also fairly well known. The period starting with Ur III, beginning with Urnammu, running down through the Old Babylonian period, ending with Samsuditana, makes up a coherent block with a known span of just over 500 years. This period is, in fact, so well known that Roux has commented, "Indeed, it can be said without exaggeration that Mesopotamia 1,800 years before Christ is much better known to us than any European country a thousand years ago, and it would be in theory possible for historians to draw a fairly complete and detailed picture of the Mesopotamian society in the eighteenth and nineteenth centuries B.C." (1992: 209).

However, the period between Samsuditana, the last of the Old Babylonian kings, and the Kassite king Kadašman-Enlil I is not well documented. Its length has been the subject of intense debate. This has resulted in a variety of suggestions for estimating how long the period lasted, which directly affects the absolute dates of all preceding periods.

Astounding changes have taken place in Mesopotamian chronology during the last century, due mainly to the recovery and decipherment of ancient written records. The shift has been a downward move, a lowering of the estimated chronologies for the periods preceding the Kassites.

Perhaps this can be best illustrated by following the change in the dates assigned to the infamous king Hammurabi. In 1904 his rule was estimated to begin in about 2342.²¹ By 1912 the estimate had dropped to 2123, and by 1928 to 2067. In 1942, Gruenthaner placed Hammurabi at about 2000, although as early as 1925 Eduard Meyer had suggested a date as late as 1947.

As more and more information became available, these dates continued to drop. During the second half of the 20th century three major positions were in vogue (Nissen 1987: 610). The first was a high chronology, with Hammurabi's first year at about 1848. Among the proponents of this view is Peter Huber, who has made statistical month-length calculations from contemporary economic texts. He confidently states that "the astronomical evidence allowed us to assert with near certainty (more precisely: with 99.99% confidence) that the Middle and Short chronologies are wrong, and to assert with 99% confidence that the Long chronology is right" (Huber 1987: 16). An even higher chronology is preferred by James Mellaart, largely because it more easily incorporates

²¹ For the early dates assigned to Hammurabi, see Horn 1957 and Gruenthaner 1942.

many of the radiocarbon dates that have been produced so far, both in Mesopotamia and in the Levant (Mellaart 1980: 12-18).²²

A more popular option has been the middle chronology, which places the beginning of Hammurabi's reign around 1792. Although this position has had some well-known advocates (Hallo and Simpson 1971: 98; Kenyon, Bottéro, and Posener 1971: 594; Kempinski 1992: 178), its greatest allure may stem from its mediating or "neutral" position between the high and low chronologies. It is the most natural choice for the non-specialist who wants a middle-of-the-road date that is non-controversial, or for the specialist who simply needs some base upon which to proceed to other issues (e.g., Nigro 2003: 345, n. 2; Porada, Hansen, and Dunham 1992: 77; Oates 1979: 24). This probably explains its use in reference works like the *Cambridge Ancient History* (1971: v. 1 pt. 2 p. 1000). Despite this widespread use of the middle chronology, it is rather difficult to find anyone willing or able to give a strong defense of the middle chronology and against the high or low chronologies.

A third alternative is the so-called low chronology, which usually places Hammurabi's ascension to the throne around 1728. Albright was an early supporter of this view (Albright 1956: 26). Siegfried Horn agreed with Albright, stating, "It is now generally believed that future discoveries can do no more than slightly change the current low chronology of early Mesopotamia, but that revolutionary changes, such as those

²² Mellaart, 1980: 12-18. Mellaart is exceptional because he actually advocates a beginning date for Hammurabi at 1930, higher than the standard "high" chronology by more than 80 years. Mellaart also claims archaeological support for his view and against a shorter chronology, although the evidence he provides is not detailed enough to be convincing.

witnessed during the past fifty years, are impossible" (Horn 1957: 7). The low chronology has continued to enjoy broad-based support in more recent decades.²³

A colloquium of ANE scholars was held at the University of Göthenburg in 1987 with the specific aim of addressing the likelihood of high, middle, and low chronologies. Paper topics and discussion included the interrelated chronologies of Mesopotamia, Egypt, Palestine, and the Aegean. At the conclusion, the majority of the conference participants agreed to the following statement: "The historical and archaeological evidence tends to support a low chronology" (Åström 1989: part 3, 77). Out of some 33 participants, 3 preferred the high chronology and another 3 preferred the middle or did not wish to express a preference, leaving roughly 4 out of 5 with a preference for a low chronology in their area of specialty.

With the passage of time the downward trend on the dates for this period has continued. Veenhof (2000) considers that information from the newly discovered Kültepe Eponym List, in conjunction with the dendrochronological dates of Kuniholm, clearly favors a low chronology. Sassmannshausen (2004) finds that the Venus table of Ammisaduqa is too ambiguous to determine between the various chronological schemes. The combination of various king lists and eponym lists led him to a chronology even lower than the traditional low chronology, with the fall of Babylon occurring around 1544-1534 (2004: 64).

A collaborative work published in 1998 suggested lowering the dates for Hammurabi even further. Using recent developments in Mesopotamian ceramic studies,

²³ Cf. Williams's dissertation (1975: 2083) that places Hammurabi c. 1725-1683; Redford (1992: 93), who appears to use the low chronology by placing the Ur III at c. 2050-1950 B.C.; and Kurht (1995: 44) who also has a slight preference for the lower dates.

particularly the development of mass-produced goblets of the Old Babylonian through late Kassite periods, the authors concluded that the Middle Chronology is too long "on the order of a century" (Gasche et al. 1998: 2). Although one might argue that a slowing of the pace at which these goblets developed would be expected during an unsettled period like the transition between the Old Babylonian and Kassite periods, Gasche argues that "the pace of a vessel's evolution is a function of the complexity of its shape, not of the stability of its social environment. Complex shapes, which are relatively difficult for the potter to produce, will of necessity change fairly rapidly, at least from the archaeologist's standpoint" (Gasche et al. 1998: 43). In addition, "in spite of the deurbanization and unsettled conditions that attended the collapse of the Old Babylonian state in northern Babylonia, the Babylonian pottery-making tradition survived and remained coherent, suggesting that the breakdown of urban-based society in that area was neither total nor of long duration" (Gasche et al. 1998: 45). While such ceramic studies are not able to give pinpoint dates, they do provide the framework within which additional studies must take place.

Subsequent study of textual sources convinced Gasche and his co-authors that the chronology could be reduced by some 85 to 105 years from the middle chronology. More precisely, the fall of Babylon in year 31 of Samsuditana could be reckoned at 1507-1491. Hammurabi's first year was exactly 197 years earlier, thus somewhere between 1704 and 1688.

The final step was to incorporate astronomical data. Among the thousands of pieces of data that were considered, the most significant were the two lunar eclipses of the Ur III period (one at the death of Šulgi and the other at the destruction of Ur during

the reign of Ibbi-Sîn) and the fact that the first year of Ammišaduqa coincided with the 8-year Venus cycle. The two lunar eclipses were determined to be those of 1954 and 1912 respectively. With a known span of 362 years between the second eclipse and the first year of Ammišaduqa, that king began to reign in 1500. As the 21-year reign of Ammišaduqa was followed by the 31-year reign of Samsuditana, the last of the Old Babylonian kings, Babylon fell in 1499. As a consequence, Hammurabi's reign may be placed at 1696-1654, nearly 30 years lower than the traditional "low" chronology (Gasche et al. 1998: 91).

The scheme of Gasche et al. has garnered followers. Warburton is leery of using the Venus dates, noting that it is universally acknowledged that “some 40% of the dates on the Ammišaduqa tablet may be incorrect. It is the scholar who determines which data he deems to be erroneous and which is selected as being reliable” (2002: 108). Nevertheless, he follows Gasche’s chronology, figuring it is more than mere coincidence “that the king-lists, lunar eclipses, solar eclipses, 8-year Venus cycles, and pottery sequences can all be aligned upon one single chronology based on the fall of Babylon in 1499 B.C.” (2002: 113).

Zeeb has investigated the recent findings from Alalakh in light of the ultra-short chronology and has found a good match. He notes that imported Cypriote wares found at Alalakh from level VIB to level V can be connected with an undisturbed sequence at Tell el-Dab‘a that stretches from the end of the 12th dynasty down to the 18th dynasty (Thutmose III). He concludes that “the fall of Babylon has to be dated in absolute terms not earlier than 1529 and not later than 1498, so that both the 'Short chronology' and the 'Ultra-short chronology' are just barely possible while a date in between is more probable

as neither the latest nor the earliest possible date for Ahmose are the most convincing" (2004: 91). In the end he favors a date of 1507, within a decade of Gasche (1499).

Krauss and Warburton consider the synchronism between Akhenaten, Shuppiluliuma I of Hatti, Tushratta of Mitanni, Ashur-Uballit I of Assyria, and Burnaburiash II of Babylon to be firm. Furthermore, they suggest that "the proposal of Gasche et al. (*Dating*) is the only astronomically and archaeologically supported chronology available today" (2006: 477).

In light of the work of Gasche et al., Novák (2007: 390 n.13) observes that "most of the scholars prefer either the low or the ultra-low chronology." Novák's own work on the empire of Mittani has led him to a similar conclusion. "From an archaeological point of view there must be a significant overlap of what is called 'Old Babylonian' and 'Mittani' Periods in northern Mesopotamia, although they appear in nearly all chronological charts as succeeding one the other with a distinctive break in between" (Novák 2007: 389). Thus, "we can eliminate both the Middle and High Chronology and must therefore choose only between the Low and Ultra-Low Chronology. This would help us eliminate one of our fictional 'Dark Ages'" (Novák 2007: 398).

It is clear, then, that the general trend in Mesopotamian chronology over the last century has very much been a downward shift. More specifically, the most recent work has been based on more and better data than were previously available, and it has produced the lowest chronologies.

Egyptian Chronology

It should probably come as no surprise that Egyptian chronology is similar to Mesopotamian chronology in the basics. The dates for the first millennium are fixed to a

point of near certainty, while those of the second millennium are more contentious, and those of the third millennium and earlier amount to informed estimates. As with Mesopotamian chronology, recent scholarship has tended to favor a lowering of second millennium Egyptian dates.

Kitchen's magisterial work on the Third Intermediate Period (TIP) began with the certain date of the establishment of the Saite kingdom in 664 B.C. He used a massive number of internal synchronisms between known reigns of kings and the rule of various priestly families to reconstruct a fairly tight historical chronology back to the end of the New Kingdom (NK), about 1100 B.C. The whole series can be pegged chronologically by a solar eclipse, recorded in a Demotic papyrus, that occurred on Sept. 30, 610 B.C., immediately after the death of Psammetichus I (Kitchen 1991: 204). The correctness of this chronology is confirmed by numerous links with Mesopotamian chronology, which is itself based on another solar eclipse, this one on June 15, 763 B.C.

For the New Kingdom, Rainey describes high and low chronologies that differ by 25 years, with the reign of Thutmose III starting at either 1504 or 1479 (Rainey 1999: 60; cf. Aharoni et al. 1993: 6).²⁴ More recently, Bietak has described the difference as amounting to about 10 years, with the start of the New Kingdom around 1550-1540. However, he also acknowledges that there is a maximum 20-year flexibility in either direction before the pressure on genealogies and reign lengths would become too much (Bietak and Höflmayer 2007: 14), so that the outside range really begins about 1570 and

²⁴ Krauss (2007: 173) observes that astronomical calculations based on the heliacal rising of Sirius do not help refine this question either, since there is no agreement on where the observations took place: Memphis, Thebes, or Aswan. In addition, it is still uncertain whether such dates were actually observed or were schematically reckoned. "The variability of these two factors alone can result in a difference of about 30 years for a Middle or New Kingdom Sirius date."

ends about 1520. Thus, for example, the *New Encyclopedia of Archaeological Excavations in the Holy Land* (1993: 1529) begins the New Kingdom at 1570, while Baines and Malek (2000: 36) start it at 1520. In effect, then, there exists a 50-year window. Bietak himself prefers the lower end of this range, placing the end of the Hyksos Dynasty 15 at about 1530 (2007: 15). Kitchen is in agreement with this, employing a range of 1540/30 (Kitchen 2007: 170).²⁵

Discussion of the Second Intermediate Period (SIP) can be somewhat confusing due to varying definitions of what it includes. Some chronologists include Dynasty 13 with the preceding Middle Kingdom, while others consider it as part of the succeeding SIP. Silverman excludes it from the SIP and calculates the period as lasting 94 years, 1630-1536 (1997: 24-32). Hoffmeier, on the other hand, appears to include it, and assigns the SIP a total of 247 years, 1786-1539 (2008: 8).²⁶ In addition, there is a partial overlap of the Hyksos Dyn 15 (the last of the SIP) and Dyn 18 of the New Kingdom. The first king of Dyn 18, Ahmose, came to power about 16 years prior to the final defeat of the Hyksos.²⁷ Thus Murnane (1995: 713) gives the end of the SIP as 1539/23, the first number corresponding to the start of the 18th Dyn and the second to the final defeat of the 15th Dyn.

²⁵ Others who favor the lower end of this range include Murnane (1995: 712), Hoffmeier (2008: 1539), Silverman (1997: 24-32), and Krauss (2007: 187). Those in favor of the higher range, around 1550, include Dodson (2002: 36), Oakes and Gahlin (2002: 16), and Russmann (2001: 260). Both CAH and NEAEHL reflect an earlier era when older dates were in vogue; both use 1570.

²⁶ See also Lawrence (2006: 29) at 255 years, and the older estimates of Montet (1958: xv) at 205 years, and Breasted (1906: 40-44) at 208 years.

²⁷ This number is derived from Murnane's estimate (1995: 713). Kitchen (1987: 44) considers a 10-year overlap "highly probable."

The biggest problem, however, is the lack of real data for determining the true length of the SIP. Kitchen (2007: 170) acknowledges this problem when he states that

one can make a very good case for estimating the length of the Second Intermediate Period (13th to 17th Dynasties) by establishing the basic succession of kings who had actually ruled over Thebes during that period. Using existing, known reign-lengths, plus analogous lengths of reign for kings of similar status, it is possible to offer a figure of some 240/250 years for the period between the 12th Dynasty and the accession of Ahmose I and the 18th Dynasty in Thebes. Here, the 240 is a decidedly minimal figure, and 250 may prove to be closer to the truth, eventually.

For this same period, however, Baines and Malek estimate 216 years (2000: 36).

Estimation and analogy of reign length figure prominently in any attempt to attach an absolute number to the length of the SIP for the simple reason that there is not sufficient data to do otherwise.

With this level of uncertainty existing in the more recent periods, it is no wonder that dates for the Middle Kingdom are also uncertain. Kitchen (1987: 47) has demonstrated that there are at least high and low possibilities for the Middle Kingdom, differing according to his estimate by 42 years. Amenemhet I, the first king of Dyn 12, could thus be estimated to have begun his reign as early as 1979 or as late as 1937 (Kitchen 1987: 49).²⁸ Twenty years later, the same difference of 42 years was again referenced by Bietak and Höflmayer (2007: 14) in his review of high and low chronologies, an indication that little progress has been made. In practice, the gap may be even wider. Baines and Malek (2000: 36) employ a date very similar to Kitchen's low chronology—1938 for the start of Dyn 12—whereas Aldred (1998: 215) advocates a date even higher than Kitchen's high date of 1979, choosing 1994 for the start of Dyn 12. This

²⁸ The difference lies in whether Sothic observations during Dyn 12 were made from the northern capital (Thebes) or from Elephantine. A fine overview of the issues involved with estimations based on the heliacal rising of Sirius is given by Firneis (2000: 58).

amounts to a difference of about 56 years. Kitchen (2000b: 46) has also observed that the length of the 12th Dyn has shrunk over the past half decade, from 205 years to only 178 years.

The period between the Old Kingdom and the Middle Kingdom is known as the First Intermediate Period (FIP). It is usually considered to commence with Dyn 7 and to end midway through Dyn 11, when Egypt was again reunified under Mentuhotep II. Many of the kings of Dyn 7-10 are ephemeral, again requiring that the length of the period be estimated using little information. As expected, there is great divergence in the estimates of how long the FIP lasted. Breasted (1906: 40) estimated nearly 400 years, while the *Cambridge Ancient History* (1971: 944) and the *NEAEHL* (1993: 1529) have given it fewer than 50 years. The average estimate runs close to 130 years (fig. 16).²⁹

What about the start date for this period in absolute terms? It is of some interest that these estimates have become lower over time. Breasted (1906: 40-44) began the FIP

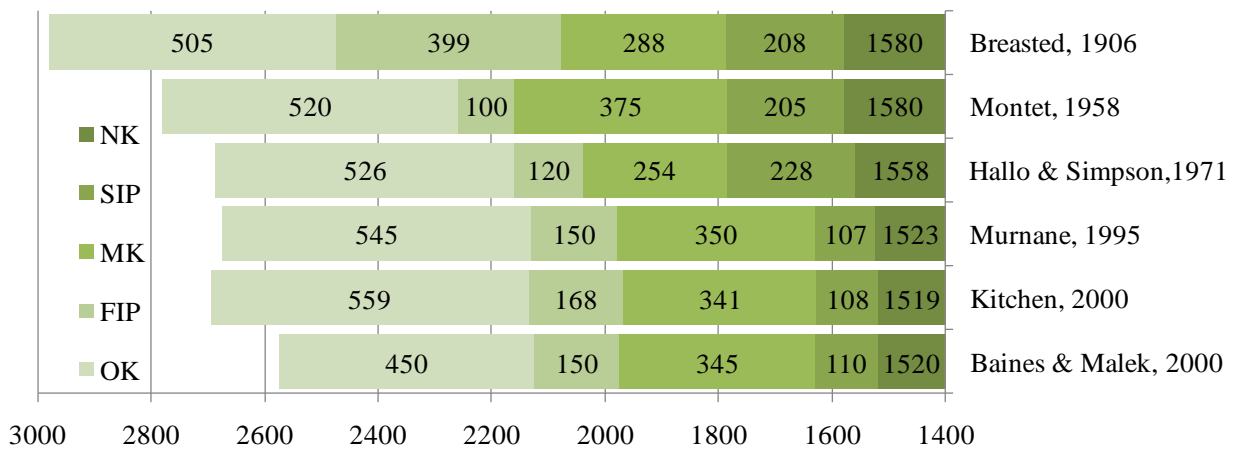

Fig. 16. Estimated lengths of the Egyptian periods, in chronological order.

²⁹ E.g., Oakes and Gahlin, 2002: 16; Aldred 1998: 11; Dodson, 2001: 36.

around 2475. Fifty years later that date had been lowered to about 2250 (Montet 1958: xv; Steindorff and Seele 1957: 274). More recently it has dropped to about 2130 (e.g., Murnane 1995: 712; Silverman 1997: 24-32; Baines and Malek 2000: 36; Kitchen 2000: 49).³⁰ This represents a lowering of the absolute chronology for the FIP by about 350 years over the last century. As with Mesopotamia, this is the result of the cumulative shortening of NK, SIP, and MK dates based on the discovery of additional data.

Dates for the Old Kingdom and Early Dynastic periods are less certain yet. Hassan (1980: 203) observed estimates ranging from 3300 to 2900 for the start of Dyn 1. Baines and Malek (2000: 36) prefer the lower end of this range, around 2950, yet admit a "margin of error" for the period amounting to about 150 years or so. Kitchen (1991: 202) concludes that dates for the OK at best can only be estimated to within about two centuries.

Two points that are relevant to the present study may be drawn from these observations. The first is that Egyptian chronology for the periods around the EB III-IV transition (end of Old Kingdom, First Intermediate Period, start of Middle Kingdom) is not yet certain. Any determination of its absolute dates would still be subject to a number of variables, the sum total of which are thought to allow differences of at least 50 years for the Middle Kingdom, and perhaps three to four times that amount for the Old Kingdom. The second point is that, as with Mesopotamian chronology, the trend among

³⁰ There are also those who opt for a higher chronology, beginning the FIP around 2180. In addition to the *Cambridge Ancient History* and the *New Encyclopedia of Archaeological Excavations in the Holy Land*, see Russman 2001: 260; Oakes and Galin 2002: 16; Hoffmeier 2008: 8. It seems likely, in light of the semi-popular nature of the last three, that they have simply adopted the *CAH* or *NEAEHL* dates for the sake of convenience.

those who work with second millennium Egyptian chronology has been to lower the dates. Newly discovered data have allowed more tightly controlled estimates of absolute chronology, and the trend over the last century has been distinctly downward.

Synchronisms

A number of synchronisms are known between Egypt, Syria/Palestine, and Mesopotamia which have a bearing on the absolute dates of the EB/MB chronology of Palestine. Although they do not establish an absolute chronology, they do put certain constraints on the regions involved, and may be the best resource for estimating absolute chronology for EB/MB Palestine. In the following discussion, synchronisms will be grouped according to where they fall in the Egyptian chronology, beginning with the Middle Kingdom and working back.³¹

Middle Kingdom: Dynasty 13

Perhaps the best-known synchronism is that of Neferhotep I of Egypt (Dyn 13) with Yantin of Byblos and Zimri-lim of Mari, a known contemporary of Hammurabi of Babylon. The synchronism was first recognized by Albright (1945: 12). It depends on the interpretation of Yantin and Yantin-Ammu as being one and the same, a correlation not proven but deemed likely. Kitchen (1987: 48) shows that this synchronism can only be made to work with a middle or low Mesopotamian chronology, since the reign of Neferhotep I would not overlap the reign of Hammurabi, using the high Mesopotamian

³¹ Synchronisms for the New Kingdom (particularly the Amarna period) and later periods are well known. The absolute chronology for those periods is so well established as to make such synchronisms of little interest to us.

chronology, even if the high Egyptian chronology is used.³² On the other hand, the ultra-low Mesopotamian dates for Hammurabi advocated by Gasche et al. (1996) work quite nicely with the low Egyptian dates. Archaeologically, Neferhotep I belongs either toward the end of MB IIA or in the first part of MB IIB (Bietak and Höflmayer 2007: 15). At any rate, he cannot be later than MB IIB, since a scarab of a subsequent king, Sobekhotep V (high 1730, low 1690), was found in a phase iii tomb (MB IIB) at Jericho (Kempinski 1992: 178). If, perchance, this scarab was an heirloom and not closely contemporary with the reign of Sobekhotep V, then the MB IIB would need to be pushed even lower.³³

For roughly this same period, Marchetti (2003: 318) links the ceramics of Jericho IVa 1-2 (MB IIA) with Tell el-Dab‘a levels G-F (Dyn 13), for which the dates are about 1755-1680.

Middle Kingdom: Dynasty 12

Levantine Painted Ware occurs in Palestine at the beginning of MB IIA (e.g., Tel Aphek phases 1 and 2; see Bietak and Kopetzky 2000: 127; Bagh 2002; Marcus, Porath, and Paley 2008: 233f.). Pottery of this type was found in the context of a temple project at Tel el-Dab‘a that was undertaken in the fifth year of Sesostris III (Bietak 2000: 28, n. 13). It also appears at Lisht in Egypt during the reign of the same king, whose dates are

³² Using a high Egyptian chronology and the middle Mesopotamian chronology, Kitchen matches Hammurabi (1792-1750) with Yantin of Byblos (1765-1735) with Neferhotep I (1738-1727), just barely. Under this scenario Hammurabi and Neferhotep I do not actually overlap, but the reign of Yantin does partially overlap both of the other two. Using low dates for both regions provides a more comfortable fit: Hammurabi (1728-1686), Yantin of Byblos (1705-1680), Neferhotep I (1696-1685).

³³ Also of interest from this same period is the mace of the Dyn 13 king Hetepibre in the early 2nd-millennium "Tomb of the Lord of the Goats" at Ebla (Kitchen 2000: 46). It is not entirely clear which king this may have been, or if he is even mentioned in the Turin Papyrus.

likely somewhere around 1850.³⁴ Thus one would expect that the MB IIa did not begin much before 1900 on a high Egyptian chronology, and perhaps as late as 1850 on a low chronology.

Along similar lines, Kempinski (1992) describes the appearance of Egyptian objects bearing the names of Amenemhet III and IV in the Royal Tombs III and IV at Byblos. These two Egyptian kings immediately followed Sestoris III, and were among the last kings of Dyn 12. These tombs at Byblos also contained pottery belonging to the late MB IIa, thus strengthening the connection between MB IIa and the end of the Egyptian 12th Dyn.³⁵ At the same time, this presents a bit of a conundrum when paired with the connection between early MB IIa Levantine Painted Ware and Sesostris III. Is the MB IIA shorter than previously estimated? How can pottery from the beginning and end of the MB IIA show up in association with three sequential kings whose reigns were not extraordinarily long (about 75 years altogether)? One possibility is that the Egyptian items in the Byblos tombs were not buried during the lifetimes of Amenemhet III and IV, but were buried later. Of course, this would place the MB even lower.

An earlier synchronism noted by Albright (1973: 15) was the discovery of several Ur III cylinder seals in the pyramid of Amenemhet II (Dyn 12). On the high Mesopotamian chronology the Ur III dates are 2167-2073, on the middle chronology 2113-2019, while the low dates of Gasche et al. would be 2015-1921. For Amenemhet II, Albright (1973: 15-16) estimated his reign around 1929-1895, Kitchen (200b: 49)

³⁴ Kitchen (2000b: 49) gives 1872-1853, the same dates employed by Bietak (2007:15, fig. 2), while Baines and Malek (2000: 36) prefer to lower the dates by some 37 years to 1836-1818. The lower system used by Baines and Malek is nearly identical to that of Krauss (2007).

³⁵ A similar connection was noted by Williams (1975: 1167).

prefers 1911-1876, and Baines and Malek (2000: 36) give 1876-1842. It seems credible that Amenemhet could have collected these items early in his 35-year reign, even as heirlooms, but it stretches credulity to suggest, as would be necessary with the high Mesopotamian chronology, that the seals had survived as a group for some 200 years before being incorporated into the king's burial cache. It seems much more likely that they came to Egypt during the lifetime of Amenemhet, even if prior to his actual reign. At any rate, there should not be an extraordinary amount of time between the reign of Amenemhet II and the close of the Ur III. Thus the Mesopotamian low chronology seems more likely.

From approximately the same period there is a cup of the Ur III period that was discovered in an EB IV tomb in Jerusalem (Dever 2003: 84). As above, the correlation between EB IV and Ur III seems to be confirmed, and the periods need to rise or fall together.

According to Redford (1992: 87), "the most precious source bearing on Egypt's relations with Asia in the late Middle Kingdom, the so-called Execration Texts, must be dated from about 1850 to 1750 B.C." Redford correlates these Dyn 12 texts with the EB IV/MB IIa transition in Palestine, indicating his opinion that the EB IV may extend as late as 1850.

First Intermediate Period

Synchronisms for the First Intermediate Period have proven to be elusive. According to Kantor (1965: 19), "the synchronization of the First Intermediate period with the Middle Bronze I of Syria and Palestine is not established by specific archaeological correlations. These periods fall into place opposite each other merely as

the successors of the Old Kingdom and the Early Bronze period." Fortunately, this picture has begun to change. Stager (1992: 41) can now point to encampments in north Sinai that have produced not only "MB I 'calciform' pottery but also, for the first time, Red Sealing-Wax Ware know from Medum in Egypt."

As noted earlier, Schaub has pointed out possible ceramic parallels between EB IV Bab edh-Dhra' and Dyn 6 in Egypt, including thin rim bowls, a cup similar to Dyn 6 votive bowls, and storage jars with combed decoration similar to wares imported into Egypt during the Fourth to Sixth Dynasties. This connection, though, is difficult to reconcile with the more widely held view that the EB IV was contemporaneous with the FIP (e.g., Esse 1991: 176; Oren 1973: 36-37; Stager 1992: 40) unless the FIP was quite short, the EB IV rather extended, or a high chronology is adopted for Palestine.

Old Kingdom: Dynasties 4-6

Some years ago it was thought that the EB III-IV transition in Palestine came at about the same time as the Dyn 5-6 transition in Egypt. Mellaart (1966: 67) placed the EB II-III transition at the start of Dyn 3, and estimated that the EB III lasted "until the beginning of the Sixth Dynasty." Hennessey (1967: 89, chart 9) similarly placed the end of the EB III at roughly the same time as the end of Dyn 5, at least for the southern Levant. Based on sparse evidence from 'Ai (collared mace heads and votive bowls), Hennessey also equated EB III in Palestine with the Early Dynastic III and Sargonid (Akkadian) ages in Mesopotamia (1967: 84).

Today, however, it is widely held that the Early Bronze III was contemporary with all of Dynasties 4-6 of the Old Kingdom (Stager 1992: 40-41; Kantor 1992: 21; Ward 1991: 11). Redford (1992: 64) posits that the end of the EB III was brought about

by the destruction visited on Palestine by the late Old Kingdom kings, although he qualifies this as pertaining only to those portions of Palestine that were within the Egyptian sphere of influence (mostly along the Mediterranean coast), not Transjordan. Likewise, de Miroschedji (2000: 339) notes the occurrence of combed Metallic Ware jars in Dyn 6 contexts, and he equates this with the latter part of the EB III. This same connection had been noted earlier by Stager (1992: 39), who concluded that the latest appearance of this ware, during the reign of Pepi II, "provides the best evidence for dating the end of the EB III in Palestine and Syria." Harrison (2000: 348) agrees, although he cautions that the correspondence between the EB III and the Old Kingdom is loose and there is "clearly a critical need for substantial further data." As if to highlight this cautionary note, Esse (1991: 106) had earlier noted a "discrepancy" in the accepted synchronism: jugs with a raised collar around the base of the neck appear in Palestine in the EB II (e.g., at Bab edh-Dhra' in round charnel house A 56), but occur in Egypt in Fourth and perhaps early Fifth Dynasty contexts.

Another synchronism is indicated by an alabaster lid inscribed with the early name of Pepi I (early Dyn 6) that was found in the Royal Palace G at Ebla, level IIB1, a palace that was destroyed by Sargon of Akkad (Matthiae 2000: 137).³⁶ In archaeological terms this was the EB IVa in Syria. The problem for now is that solid dates for all three, Pepi I, Sargon of Akkad, and the start of the EB IV, remain elusive.

As noted earlier, Dynasties 7-11 are not at all well known. Even the number of kings is not certain, much less how long each reigned. Documents like the Turin Papyrus

³⁶ Sargon's estimated length of reign was about 55 years. Thus his reign may have been around 2390-2335 (high), 2340-2285 (middle), or 2240-2185 (Gasche et al. 1996).

and the Abydos King List provide very different numbers for the kings that they do list (see Kitchen 2000: 47).

In Mesopotamia there is, of course, the uncertain length of the early Kassite period. In addition, when it comes to figuring the absolute dates of Sargon of Akkad, this is complicated by the uncertain length of time that separates the Akkadian and Ur III periods.³⁷ Indeed, the King List describes this period as one of which it could be said "Who was king? Who was not king?" (Oates 1979: 37). The combination of these periods of uncertain length allows estimates that vary by centuries.

For north Syria, it is not at all clear how closely EB IV of that region corresponds with the EB IV in Transjordan. Esse (1991: 143) notes that northern Palestine was different from southern Palestine all through the Early Bronze Age. Thus, even if firmer dates could be established for the start of the EB IV in Syria, this would not necessarily indicate the start of the EB IV in southern Transjordan.

PreDynastic Egypt: Dynasties 1-3

For an even earlier period, Kantor (1992: 19-20) is able to reference several connections between Dynasties 1-3 in Egypt and the EB II of Syria and Palestine. There are numerous examples of EB II Syro-Palestinian pottery recovered in Egyptian tombs, especially Dyn 1 tombs. Byblos has yielded a stone vessel fragment with the name of the Second Dynasty king, Khasekhemy, and Egyptian stone vessels have been discovered in EB II contexts at Ai in Palestine. The same context at Ai yielded an ivory knife handle

³⁷ "The history of the period that separates the end of the reign of Shar-kali-sharri from the establishment of the Third Dynasty of Ur is not at all well known" (Kuhrt 1995: v. 1, 58). Oates (1979: 43) viewed the length as "probably no more than a century, but whatever dating system is adopted the discrepancy is unlikely to exceed 100 years." The dates given in the previous note are based on an estimated length of about 45 years for this period (see e.g., Porada, Hansen, and Dunham 1992: 10).

decorated with a pattern well known in Egypt among the matting designs painted on several First Dynasty mastabas as well as in a Third Dynasty tomb. According to Kantor (1992: 20) this particular design does not appear after the Third Dynasty. However, Ward (1991: 13) suggests that the vessel fragment of Khasekhemy was likely from an "antiques" storehouse in Egypt, and thus that the EB II may extend into Dyn 3. Burnished Metallic Ware has also been found in both EB II contexts and in the tombs of First Dynasty Egypt (Fischer 2008: 201), indicating overlap between the two.

As mentioned above, in the EB II at Bab edh-Dhra' for the first time a type of pottery is present that is also found in Egypt, Red-Polished Ware, also known as "Abydos" Ware. In Egypt, Red-Polished Ware appears in Dynasty 1 contexts (Amiran 1969: 59-66; Stager 1992: 35). This makes them contemporaneous, but does not establish absolute dates.

Summary

The absolute dates derived from synchronisms can be no more certain than the date of the best-known component. Synchronisms may, in select cases, help in choosing between multiple possibilities. It is not possible, for example, to hold to a low Egyptian chronology and a high Mesopotamian chronology in the second millennium (Matthiae 1989: 167). They must rise and fall together. Likewise, the trend toward lower Egyptian and Mesopotamian chronology in general should have, through synchronisms, the effect of pulling the chronology of Palestine lower, although historians of the Levant have been slow to do so.

Radiocarbon Dates in the Levant

There are three reasons why radiocarbon is inextricably linked to the chronology of Bab edh-Dhra' and Numeira and why it is necessary to understand the strengths and weaknesses of the method. First, ^{14}C figures prominently in the current debate over broader issues of chronology in Egypt, Cyprus, Palestine, and Mesopotamia. The most heated debate is currently over the dating of the Thera eruption. There is about a century difference between the dates suggested by Egyptologists (e.g., Viennaer 2001) and those defended by the ^{14}C community (e.g., Baillie 1990). This debate has ramifications not only for Egyptian chronology but also by extension for the rest of the ANE. Bruins and van der Plicht also note that "the beginning of the Chalcolithic in the Near East has 'become' a [*sic*] 1000 years older, from about 4000 in the 1960s to about 5000 BC in current perception based on ^{14}C dating. . . . The new ^{14}C evidence is overwhelmingly in favor of an older Early Bronze Age and older dates for Dynasties 1-6" (2001: 1321).

Secondly, ^{14}C has played *the* critical role in determining the absolute chronology of the EB III-IV dates in Palestine for some historians and archaeologists. Dever considered the start of the EB IV to be "fixed by Radio Carbon dates at about 2350 B.C." (1973: 59). Mellaart noted the disparity between the dates suggested by historical archaeology and ^{14}C and chose to accommodate the ^{14}C by using a high chronology, starting the EB IV at about 2380. "A confrontation of the calibrated radiocarbon record with the historical middle and high chronologies shows an incompatibility of the calibrated carbon dates with the middle, but not with the high chronology. There is therefore no reason to ignore the calibrated C_{14} dating, or to demand that the physicists adjust their dating to the middle chronology, and one attempt to do so by McKerrell has rightly been rejected by the physicists as not justified" (Mellaart 1980: 18). Bruins and

van der Plicht (2001) recommend extending the EB I-III back about three centuries, based solely on the results of ^{14}C dating. Schaub and Rast discuss five EB IV ^{14}C samples from field X at Bab edh-Dhra'. After excluding two of the dates as unacceptably early, they chose the single short-lived sample from among the remaining three (P-2573, olive stones, calibrated 1σ date 2335-2135 B.C.), picked a date at about the middle of that range, and stated that "a date of approximately 2200 B.C. for these two tombs is consequently indicated" (1989: 502).

Finally, there are 21 ^{14}C dates from Bab edh-Dhra' and Numeira. In 1973, Schaub used a few initial ^{14}C results to place the end of the EB III at Bab edh-Dhra' around 2350.³⁸ The same date was assigned by Rast for the end of the EB III at Numeira, "based on C_{14} results and pottery" (Rast 2003:327).

Since so much rests on radiocarbon dating, it is necessary to investigate the question of what radiocarbon dating is capable of producing, how reliable or accurate it is compared to other methods, and how ^{14}C dating has been used, or perhaps misused, in building the chronology of ancient Palestine.

Basics of Radiocarbon

History

Radiocarbon dating was first proposed by Willard Libby in 1947 and more fully developed over the next few years. It is based on the theory that every living thing takes in ^{14}C while it is alive, so that it has the same proportion of ^{14}C in itself as does the

³⁸ Schaub 1973: 17, n. 48. The structure being dated by Schaub at this point was funerary building A 8, which he placed right at the end of the EB III. The ^{14}C date given is M-2036, 2192 ± 180 , 1σ . In light of ensuing discussion, this appears to be the straight-up BP date determined by the U. of Michigan lab, minus 1950. Using the newer half-life for ^{14}C and also applying the then-new bristlecone pine calibration curve of Suess resulted in a corrected date of 2350 ± 180 , which became the basis of Schaub's chronology.

atmosphere in which it lives. Upon death the intake of ^{14}C ceases and the amount of ^{14}C in the organism begins to lessen predictably as the ^{14}C decays into ^{12}C . Libby figured the half-life of ^{14}C as $5,568 \pm 30$ years.³⁹ So in theory if he measured the amount of ^{14}C in an item and found it to be, say, exactly half of the original amount, he could determine that it was about 5,568 years old.

There are three common methods for measuring the ^{14}C content in a sample. Gas proportional counting (GPC) uses organic material that has been combusted and converted to CO_2 . The number of radioactive decays that occurs over a given amount of time is then counted, and the amount of ^{14}C is then extrapolated from this rate.⁴⁰ This was Libby's original method. He estimated that the decay rate for modern ^{14}C would be about 14 disintegrations per minute per gram of carbon. The required sample size for this method is about a gram. GPC is currently the most widely used radiocarbon measurement method.

Accelerator Mass Spectrometry (AMS), first developed in the late 1970s, allows the number of ^{14}C atoms to be directly counted, rather than just inferring their number from the number of decays. Among other things, this method allows the use of a much smaller sample, in many cases less than 1 mg (Currie 2004), and results can be obtained in a matter of minutes rather than weeks. Although AMS labs require a much smaller sample, they are no more accurate than GPC labs (Kutschera and Stadler, 2000).

³⁹ By 1949 Libby had revised the half-life to 5720 ± 47 years (Arnold and Libby, 1949), and the University of Cambridge eventually determined that 5730 ± 40 was closer yet. However, for the sake of consistency when comparing results, the old half-life of 5568 continues to be used in most calculations. The difference is not relevant when the sample is calibrated using a calibration curve based on the old half-life number.

⁴⁰ For a more detailed description of the methods and requirements of GPC, see Kromer and Münnich (1992).

Liquid Scintillation Counting (LSC) was first used in 1953. It involves dissolving the sample to be measured in a solvent that also includes scintillators. When particles decay, they cause the scintillators to emit light, which is then measured by photomultiplier tubes. There have been complaints with regard to performance, stability, and reproducibility of results, and software introduced computational errors, although advocates of the method give ready counter-arguments (e.g., Polach 1992).⁴¹

During the 1960s it was discovered that the results of ¹⁴C dating on known-age tree rings did not match the expected decay rate. It was eventually determined that the ¹⁴C content of the atmosphere must have varied over time. Based on the assumptions that the tree-ring counts were correct and that their wood accurately reflected historical atmospheric levels of ¹⁴C, a calibration plot or "curve" was created that could be used to correct for these historical fluctuations in ¹⁴C determinations. Tree rings of known age were ¹⁴C dated, and the resultant numbers were used to correct or calibrate the dates of other items. Thus it became standard practice to begin with a "before present" (BP) date, based on the year 1950, accompanied by an error range, and then match that date against a calibration curve to "calibrate" it.

As can be seen from the 1970 curve (fig. 17), most dates earlier than about 800 B.C. become even older when moved from the theoretical straight-line decay rate to the tree-ring-based calibration curve.

The calibration curve has been refined and updated many times since it first appeared. The most recent curve to be published, as of this writing, is INTCAL04,

⁴¹ More detailed information on this method is available at <http://www.c14dating.com/lsc.html>.

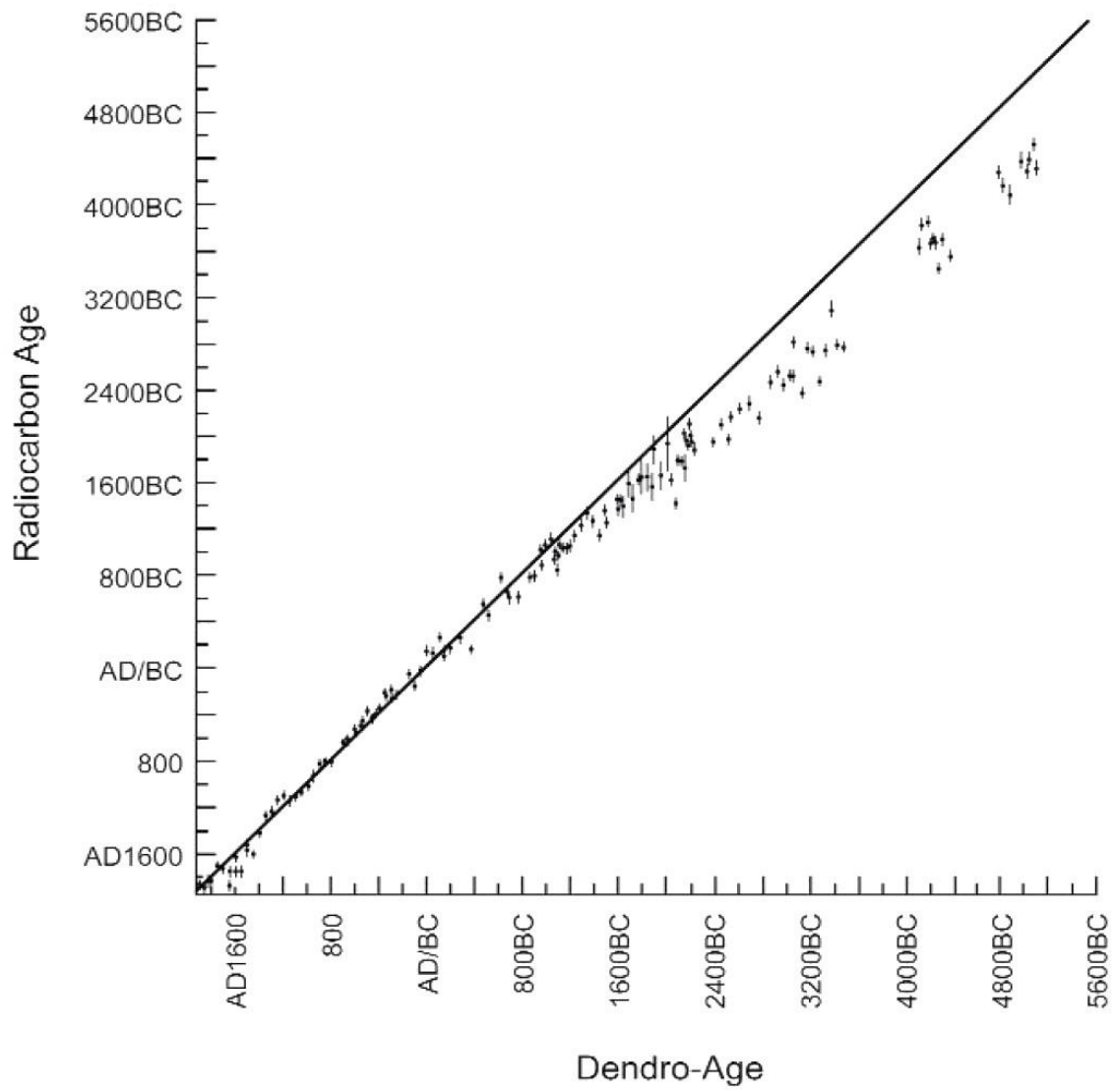

Fig. 17. The 1970 radiocarbon calibration curve (Currie 2004).

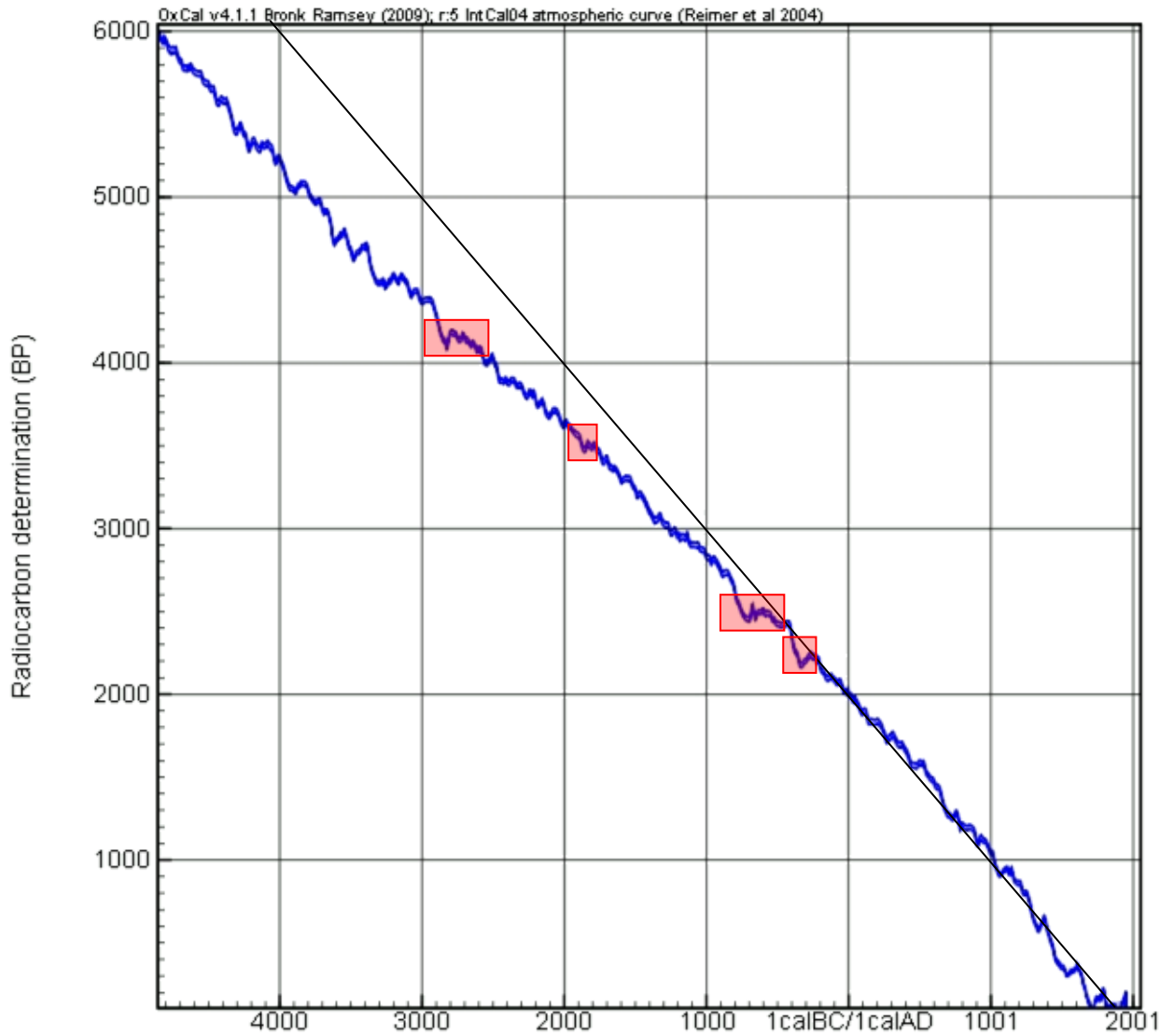

Fig. 18. The IntCal04 calibration curve, with some of the numerous flat areas highlighted.

published in 2004 (fig. 18). It provides a calibration curve based on tree-rings back to about 12,000 B.C., and then back as far as 25,000 B.C. based on fossilized corals.

Assumptions

Radiocarbon dating is based on a number of assumptions:

1. *The sample to be dated is uncontaminated.* Contamination of a sample, either with older material that has little or no ^{14}C or with newer material that has excessive ^{14}C , will skew the results. Contamination can happen in nature prior to collection of the sample, in the field during collection, or in the laboratory (van der Plicht and Bruins 2001: 1161). The challenge, of course, is to determine beforehand whether or not the sample is contaminated. In the literature unexpected dates are commonly blamed on contamination, regardless of whether other evidence for contamination exists or not. There is no certain way to determine whether a sample has been contaminated other than by unexpected dating results.

2. *Atmospheric or environmental levels of ^{14}C for past periods of time are known.* Initially it was assumed that the levels of atmospheric ^{14}C have always been constant. Radiocarbon dating of tree-rings seems to have proven that initial assumption wrong. Past fluctuations in ^{14}C levels must be known in order for age to be estimated.

3. *The sample is associated with the correct archaeological setting.* Samples that do not have a clear archaeological context cannot be used to establish the age of any surrounding material. Related to that, it is possible that long-lived organic material like wood may have lived decades or even centuries before the archaeological context in which it is found, either because it was already very old when it was cut or because the wood was re-used. Short-lived samples (e.g., grain, olive pits, bones) are often preferred

for ^{14}C dating, although even these may be misleading since they are usually single-year whereas the calibration curve they are being matched against are decadal or even bi-decadal and therefore somewhat smoothed (Harkness 1983: 32).

4. *Individual laboratories are able to accurately measure ^{14}C content.* Part of the Fourth International Radiocarbon Intercomparison (FIRI) project involved comparing labs with each other for accuracy. This required "accepting the consensus values as, in some sense, the true age/activity for each material" (Scott 2003: 260). For radiocarbon activity this approach makes sense, since activity is measured directly. For age, though, the picture is much more complicated. In fact, so long as the measurements are not completely random, there would be some "consensus" (middle 50%) by which other measurements could be profiled. If "consensus values" are indeed used to determine age, the reasoning becomes circular and the results are not falsifiable, regardless of where they fall in relation to true calendar dates. Scott (2003: 287) concludes that

for our materials, we must assume that we can define (through calculation) what the "true" ^{14}C age will be (the consensus value), and then, we can estimate for each laboratory whether there is a constant offset from this consensus (hence, a measure of accuracy). This is not an ideal situation since the issue of precision of the estimate of the consensus value should also be considered. However, the consensus value is based on a large number of results and so its precision is high, relative to the individual measurements.

5. *The dendrochronology used to build the calibration curve is reliable.* The use of ^{14}C to place tree-rings in some dendrochronologies has been viewed by some as circular reasoning, a possible invalidation of current calibration techniques (e.g., Kromer et al. 1986; Newgrosh 1990, 1992; Kutschera and Stadler 2000; Cichocki 2000). Not all dendrochronologies have been fully published, so that the reliability of their construction cannot be checked. Physicists must therefore proceed on the assumption that they do not contain significant errors.

It is worth observing the difference between "precision" and "accuracy." The quoted error on a measurement is the measure of its "precision." "Ideally, it quantifies the variation to be expected in the measurement were it to be repeated many times" (Scott 2003: 287). Thus, a high-precision date is one with a low quoted margin of error, and one in which a repeated measurement would be expected to produce similar results. By contrast,

accuracy is concerned with the 'correctness of the result.' Ideally, with exactly known-age samples, this could be independently estimated (for our dendro-dated samples, the true ^{14}C age is not known exactly, but only within a range, due to that [*sic*] fact that it is measured). The master measurements are based on decadal samples, which do not correspond exactly to the samples provided in FIRI. This range could be as much as 100 yr, which corresponds to twice a commonly-quoted error value. (Scott 2003: 287)

Thus it is clear that precision and accuracy are two very different concepts, and a high-precision measurement is not necessarily accurate when it comes to determining real age.

Inherent Weaknesses

There are some inherent weaknesses in radiocarbon dating that cannot be mitigated, even if the foregoing assumptions were proven to be correct.

1. *Radioactive decay happens randomly.* Because of random decay, the results of repeated measurement will always spread around a "true" value. "True point dates cannot be achieved with ^{14}C dating as there always is a standard deviation" (van der Plicht and Bruins 2001: 1159).

2. *Random radioactive decay includes the predictable occurrence of outliers.* This, of course, assumes that multiple readings are taken. In the case where few or only one determination is made, it is difficult or impossible to statistically identify "outliers." In one controlled inter-laboratory comparison,

a total of 122 observations out of 1056 (i.e., slightly over 10%) were identified as anomalous (i.e., outliers). From the statistical definition of an outlier, around 5% of the results would have been expected to have been classed as outliers. Thus, approximately twice as many outliers were identified as would be expected if they were occurring purely by chance. (Scott 2003: 173)

3. *The calibration curve is wiggly.* This compounds the problems associated with trying to narrow down date ranges. In many cases a single point date would have multiple intersections with the calibration curve, and the application of the broader range that is necessary with a standard deviation always increases the possible intersections.

4. *Assessment of error rates is subjective.* Shaw points out that "the phenomenon of inter-laboratory bias and the more serious fact of the different methods used in assessing error in dates mean that the results of such syntheses (even if the F-test of contemporaneity is applied) are potentially misleading" (Shaw 1985: 301; also Pearson and Stuiver 1986: 840). Regarding the choice of σ "cut-off" points, Scott states that "the choice of cut-off points is subjective" (2003: 250). In some cases this results in lab-stated error rates that are not reliable. For example, in the FIRI comparison the evidence "show[s] clearly that the distribution of the differences between each of the duplicate pairs *does not correspond to the claimed uncertainties in the measurements*, since the means and standard deviations do not agree with the theoretical values. This would suggest, in general, that the differences between duplicates are more varied than would be expected, given the quoted errors" (Scott 2003: 219, emphasis added).

Known Causes of Variation

Comparison between radiocarbon labs that have dated the same samples has revealed what appear to be systematic variations that stem from a number of different sources. The Fourth International Radiocarbon Intercomparison (FIRI) was undertaken

in 1999 and published in 2003 (Scott 2003). For reasons not well understood, accelerator mass spectrometry (AMS), gas proportional counting (GPC), and liquid scintillation counting (LSC) labs do not produce the same dates. LSC labs in particular tend to produce broader dates and more "outliers." As the authors of the FIRI report noted, "In the main, although not solely, the extreme results have been reported by liquid scintillation laboratories" (Scott 2003: 165). "Thus, for LSC, bigger differences in the results can be expected and we can expect more variation in the LSC results compared to AMS or GPC results" (Scott 2003: 223).⁴²

Furthermore, in some cases there are variations in the ages reported by different types of labs (fig. 19). The FIRI analysis "also appears to indicate some differences in

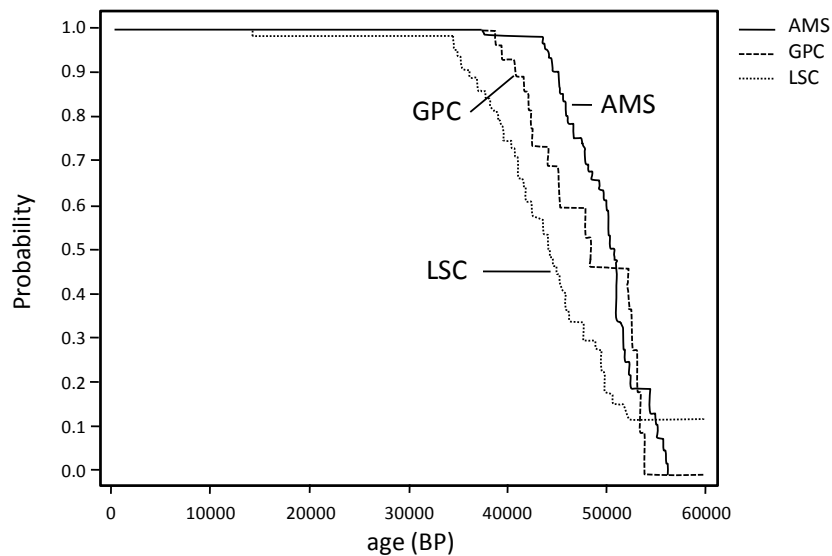

Fig. 19. Variation of date results by laboratory type, after Scott (2003, p. 246, fig. 6.15).

⁴² It may be worth noting that over half (44/85) of the participating laboratories were LSC labs (see the list given in Scott: 2003: 152). Among them is the Kimmel Center, Weizmann Institute, Israel, which has figured prominently in the debate between Mazar and Finklestein over the dating of the Iron Age.

the distribution of results between laboratory types, with AMS laboratories quoting older ages in general" (Scott 2003: 233). Again, "the AMS laboratories report a significantly older mean age for this sample [Kauri wood] . . . than either LSC or GPC laboratories" (Scott 2003: 240).

For some sample types, pre-treatment makes a significant difference in results. In FIRI, "there was a significant difference between the acid-leached and non-pretreated results. . . . The acid-leached results are younger" (Scott 2003: 206). "Thus, it was concluded that the apparent large age differences reflected purely a pretreatment effect, and that consistent application of the no pretreatment instruction would avoid any problem with this sample" (Scott 2003: 149). Radon contamination was also determined to be responsible for "age shift."

Finally, different materials used as a modern standard can affect the results. "Laboratories using benzene as a modern standard material quote, on average, lower ages for this sample" (Scott 2003: 189).

There has for decades been an uneasy relationship between dendrochronology and radiocarbon. In theory, either one should be able to produce absolute dates independently of the other. In reality, tree-rings have been used to adjust the calibration curve for ^{14}C , and ^{14}C has in turn been used to place floating sections of tree rings in various dendrochronologies, especially in the Mediterranean region (e.g., Kuniholm et al. 1996; Cichocki 2006).

There is some evidence for the translocation of sugars and resins across tree rings (McCormac et al. 1998). Such movement could throw off the ^{14}C measurements and thus disturb the calibration curve. There does not appear to be a solution for this problem.

Also, tree-ring patterns are only valid within one genus (or species) of tree, and a dendrochronology is only valid for that wood species and its growing area (Cichocki 2000: 62). This is less of a problem when large amounts of wood are available for constructing a tree-ring sequence, as with the Irish Oaks or the bristlecone pines, but it poses a problem for using dendrochronology for dating artifacts recovered from archaeological excavations, as it is often difficult to determine the species of tree that has been recovered. In addition, cedar that is recovered in Egypt came from elsewhere (e.g., Lebanon, Algeria, Cyprus), and each possible source location is likely to have had its own distinct growth patterns and ring sequence. "Yet even in Lebanon distinct growth areas seem to exist differing from one another in annual micro climate" (Cichocki 2000: 65).

It has proven impractical to take ^{14}C measurements from each individual growth ring when constructing calibration curves. Therefore dendrochronologists have tended to use samples, such as every tenth ring. This has the effect of smoothing the curve, since fewer data points are used. It could potentially result in the curve missing spikes or dips that actually occurred in the intervening rings.

Use of Radiocarbon

It has become common practice for archaeologists to gather organic material in the field for ^{14}C analysis. However, there is often reluctance on the part of the archaeologists, and to some extent even the physicists, to accept the results. Those who work in the ^{14}C laboratories tend to be least critical of the results. As an example, van der Plicht and Bruins (2001: 1164) suggest that

^{14}C dating in the Near East and Eastern Mediterranean has entered a crucial verification and correction phase of archaeo-historical chronologies. There is now

increasing ^{14}C evidence that the early part of Egyptian history seems older than currently assumed on the basis of scholarly reasoning. Time ought to be measured by physical dating methods, ^{14}C , and dendrochronology as a standard procedure. Complex archaeological age assessments based on cultural definitions and foreign synchronisms have their own value, but the inherent danger of circular reasoning must be recognized.

Or again, after quoting from a less-than-optimistic evaluation of radiocarbon dating by Weinstein (1984: 1156), "Somehow, the tremendous significance of direct time measurement by ^{14}C independent of scholarly opinion was not sufficiently appreciated." Yet every date produced by ^{14}C is scrutinized both by physicists and by archaeologists, to identify "outliers" or contaminated materials and to assess their reliability. *No one* is willing to accept the reliability of all ^{14}C determinations, as they often conflict with each other. Yet Manning complains that "the level of ultra-skepticism directed now at the radiocarbon evidence is not also so directed at the archaeological evidence and its synthesis. The playing field is not level" (2007: 106).⁴³

Despite these optimistic statements, there has always been a certain skepticism toward ^{14}C among consumers of the data, archaeologists and historians. This skepticism is rooted in several issues. The first is the imprecision of the radiocarbon method. ^{14}C has typically been unable to provide narrow chronological results. It is often less precise than other methods. A second issue is the tendency of ^{14}C determinations to provide dates that are significantly older than the ages obtained using other methods of calculation (lunar dates, compiled reign lengths, etc.). Finally, radiocarbon estimates have been dogged by

⁴³ It probably does not help Manning's case that, even within this article, he rejects 2 of 16 ^{14}C determinations, short-lived ones at that, as having "no clear explanation" (Manning 2007: 108, n. 3). He also recommends adjusting the calibration curve itself, since a problematic steep slope in the curve is "strongly influenced by one date on Irish Oak for a bidecadal sample" (2007: 108). These kinds of adjustments serve to highlight the fact that ^{14}C analysis is open to, and even requires, interpretation at least to the same extent as other methods of calculating absolute chronology.

issues of inconsistency, with samples that come from the same strata sometimes having dates that vary widely from each other.

¹⁴C Dates Too Imprecise

As early as 1975, Lapp (1975: 39) declared that

it is a common misconception that Carbon 14 has also made important contributions to chronological precision in the historical period. From the third millennium B.C. on Carbon 14 dates can do no more than corroborate in a very general way the datings derived from the study of pottery and other artifacts. If pottery from a certain stratum points to a date in the first half of the sixteenth century B.C., it is reassuring to have a Carbon 14 date of 1720 ± 175 B.C. On the other hand, if the Carbon 14 date came out 1257 ± 160 B.C., it should more than likely be dismissed as a contaminated sample. Carbon 14 dating is not precise enough to contribute to chronological precision in the historical period.

At least part of the question is what qualifies as a useable date. Dates within one standard deviation (1σ) are statistically likely to include the true date 68% of the time. Dates within two standard deviations (2σ) have a 95% likelihood of including the correct date, while those at three standard deviations (3σ) have about a 99% chance of covering the true date. In reality, 1σ date ranges are not far above a 50/50 probability, yet they are by far the most commonly cited. Why? Because the 2σ and 3σ date ranges tend to be considerably broader. Yet Ottaway observes that "the scientists who have produced the various calibration curves tend themselves to use a 2-sigma range, that is, a date ± 2 -sigma, in order to produce confidence limits at the 95% probability level. Implicitly they are urging archaeologists to adopt the same practice" (Ottaway 1983: 3). This same conviction is echoed by Baillie: "What is clear is that 2-sigma limits must always be used if serious misinterpretations are to be avoided. Few individual routine dates can be calibrated to better than a 400 to 500 year range, though replicate dates may allow this figure to be reduced to around 300 years. No routine dates can be sensibly interpreted in

the mid-1st millennium BC" (1983: 60). Harkness sounds a similar note of caution when addressing the then-new high-precision calibration curve: "In particular there is the distinct possibility that the 'near absolute' character of the new calibration tool could foster an attitude of unwarranted optimism in the interpretation of the resultant calibrated dates" (1983: 27). He concludes, "The foregoing discussion has attempted to highlight the fact that the advent of a high-precision calibration curve requires that potential archaeological users be acutely aware of the overall level of uncertainty inherent to the interpretation of radiocarbon ages. *Due recognition of the range of analytical confidence whether for conventional or calibrated age measurements is rarely sufficient*" (1983: 33; emphasis added).

In 1985, Shaw observed that "the major disappointment of the Irish oak curve is that it definitely establishes the fact that, for any level of C-14 in an artifact, there may be up to half a dozen corresponding calendar dates" (1985: 297). In an almost humorous turn, he notes that "the imprecision of radiocarbon dates is less of a problem in the prehistoric period, since there is no comparable absolute chronology" (1985: 299). So, the imprecision is not so bothersome when it cannot be checked against anything of known age. In relation to Egyptian chronology, "the nature of the calibration curve itself means that calibrated ranges, even at low standard deviations, inevitably overlap, creating a radiocarbon chronology which is too ambiguous to act as a check against the conventional chronology," and that "their role, even with high-precision calibration, can only be that of commentary on the existing framework" (1985: 303-4).

Pearson and Stuiver conducted a study in 1986 that was based on a comparison of 20 different radiocarbon laboratories. Their conclusion was that the reported standard deviation is usually too low.

When identical tree-ring samples (with approximate ages of ca 5000 ^{14}C yr) were measured by 20 laboratories (International Study Group, 1982) it was found that the reproducibility of standard deviations in the submitted data set were substantially higher than the age errors reported by the laboratories. Systematic errors ranged from <20 yr (3 laboratories) to 200 yr (1 laboratory). . . . The above studies indicate that systematic errors may exist, and that the reported standard deviation of a ^{14}C age measurement is usually too low. (1986: 840)

Although it has been suggested by some that the standard deviation for most ^{14}C dates should be doubled to provide more realistic error values (Weinstein 1988: 240, n. 5), Pearson and Stuiver caution against such an approach because "the original σ is not a properly defined standard deviation in many instances" (1986: 840).

It was this kind of imprecision that led Weinstein to conclude that "Palestinian archaeological and historical evidence generally provides more accurate dates for most cultural remains and stratigraphic phases after c. 2000 B.C. than can be obtained through Carbon-14 dating. Thus it is inappropriate to submit samples from Iron IB (c. 1000-900 B.C.) or IIA (c. 900-800 B.C.) contexts, or from a LB IIB/early Iron IA destruction, since the resultant dates, even if derived from short-lived and well-stratified samples, will be superfluous at best. . . . Hence there is little to be accomplished right now by submitting any radiocarbon samples from Middle or Late Bronze Age or Iron Age destruction debris" (1986: 245-6).

Kitchen has echoed this same belief, stating that "so far radiocarbon studies, including those incorporating calibration, have not yet brought us to the point where they can improve on historical dating" (1991: 201). He elaborates, "When Egyptologists are locked in a battle over whether to start the eighteenth Dynasty in 1550, 1540 (or even

1530) BC, haggling over just a decade or so, then radiocarbon dates are no help. A normal standard deviation of c. ± 80 years usually translates to a range of about three centuries after calibration" (1991: 204). Kitchen's view of the credibility of ^{14}C has not improved over time. As recently as 2007 he summarized his view this way:

At the end of the day, the chronology of the Ancient Near East/Ancient East Mediterranean has to depend on written sources for the periods when and where these exist. In their absence, archaeological sequences of assemblages using stratigraphy give us sequence, but not absolute dates. During the last century, highly ingenious "scientific" procedures have been developed to try to overcome the problem of fixing absolute dates, especially when explicit written records are lacking, including use of astronomy, radio-carbon, tree-rings, ice-cores, and so on. However, each of these is subject to various flaws that prevent attainment of absolutely reliable results, so far. (2007: 163)

In addressing the chronology of the Bronze Age in Cyprus, Merrillees (1992: 51) noted that

radiocarbon dates for the Bronze Age of Cyprus have proved no less of a help and a hindrance to chronological investigation than elsewhere in the eastern Mediterranean. While for Manning "they may be used with caution until additional reliable dates become available" (Manning 1988: 68), Åström declares that they "are not useful for exact dating" (Åström 1986: 39). Like all other scientific aids to archaeological research, radiocarbon dates are invoked if they support a particular hypothesis or position reached independently on an empirical study of the evidence, and dismissed if they do not.

For Merrillees it appears that radiocarbon dates are almost irrelevant for Bronze Age Cyprus. A similar view was expressed by Ilan with regard to dates for the Levant: "It is considered axiomatic that, given the problems of standard deviation and calibration, radiocarbon dates are superfluous for Near Eastern contexts after ca 2000 BC, since relative chronology tied into Egyptian historical data can provide closer and more reliable dating" (Ilan 1998: 299). For Mesopotamian chronology, Gasche describes the limitations of both ^{14}C and dendrochronology, which is due to the undeterminable span of time between the cutting of the timber and the final deposition in the archaeological

record. He concludes, "While we recognize the great potential of these techniques for chronological investigations, they unfortunately have been able to contribute little information to the present undertaking" (Gasche et al. 1998: 11).

There are numerous instances where published radiocarbon dates are so broad as to be nearly useless. The Naḥal Ḥemar ^{14}C measurements, for instance, were from short-lived samples including yarn, cordage, and cloth, which ought to have the best and narrowest results. The results were published uncalibrated (Schick 1988: 31). When calibrated with Stuiver's 1998 curve, several of these Neolithic measurements have a 2σ range of over 1,000 years. Examples like this abound throughout the literature. The imprecision of such measurements seriously degrades any potential value.

^{14}C Dates Too Old

From the very first, radiocarbon estimates have tended to be too old. In 1949, Arnold and Libby published a series of ^{14}C measurements on items of known age, including dendro-dated wood and items from Egyptian tombs of known age. The results showed an amazing match between nearly all the samples, and the test was heralded as proof that ^{14}C dating was reliable. Ironically, if those same determinations are calibrated using one of the modern calibration curves, most of them are shifted older. Had the scientific community known then what it knows now, it may have been less enthusiastic in accepting the new method. It could be argued, of course, that Arnold and Libby were working with a method that was still in its infancy. That is true, yet the tendency toward excessive age has continued. Albright observed in the early 1960s that already there was "a tendency in radiocarbon counts to reckon lapsed time at a little too high a figure" (1961: 39, n. 14).

In 1984, a group of scholars collected 80 samples from various Egyptian monuments and had them ^{14}C tested by two different labs, Southern Methodist University (SMU) in the U.S. and Eidgenossisch Technische Hochschule (ETH) in Zurich, Germany.⁴⁴ The resultant ^{14}C estimates averaged 374 years higher than the Old Kingdom dates given in the *Cambridge Ancient History*. A few of the samples were younger, but the majority of the dates were older (fig. 20).

Differences between historic and radiocarbon ages were calculated as averages for each of the following groups: charcoal (414 years), wood (294 years), and straw and grass (325 years); the average of all dates was 396 years (Haas et al. 1987). The authors suggested that part of the difference may be due to old wood effect, although the fact that the short-lived straw and grass samples were nearly identical undermines that argument. They concluded "that radiocarbon dates suggest that events in the Old Kingdom, up to the 6th Dynasty, are older by at least three centuries than established by traditional historical reconstructions" (Haas et al. 1987: 597; see fig. 21).⁴⁵ Of course, another possibility is that there is a systematic error somewhere in the radiocarbon scheme (e.g., Newgrosh 1992).

A series of six radiocarbon determinations from the Pre-Pottery Neolithic B site of Yiftah'el was published in 1987. The samples were short-lived, consisting of lentils

⁴⁴ The labs were Southern Methodist University (SMU) in the U.S. and Eidgenossisch Technische Hochschule (ETH) in Zurich, Germany.

⁴⁵ Weinstein (2003) notes that this conclusion was somewhat changed in Bonani et al. 2001 to align more with conventional dates, at least for the Archaic period.

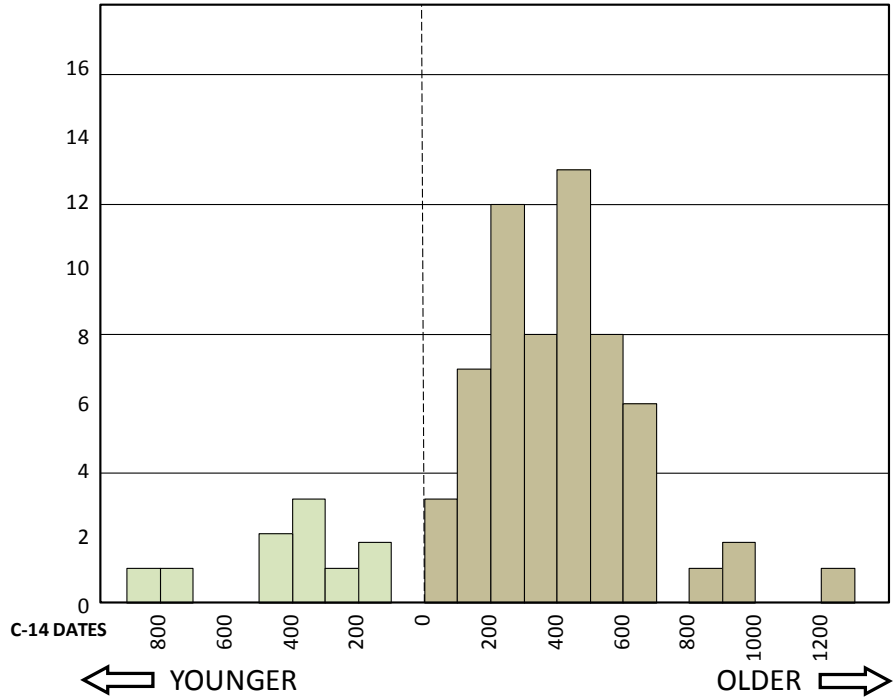

Fig. 20. Dates from the 1987 study by Haas et al., showing the number of samples and grouped according to how they diverge from the dates given in the *Cambridge Ancient History* (CAH), whether older or younger; adapted from Haas et al. (1987: 600, fig. 1).

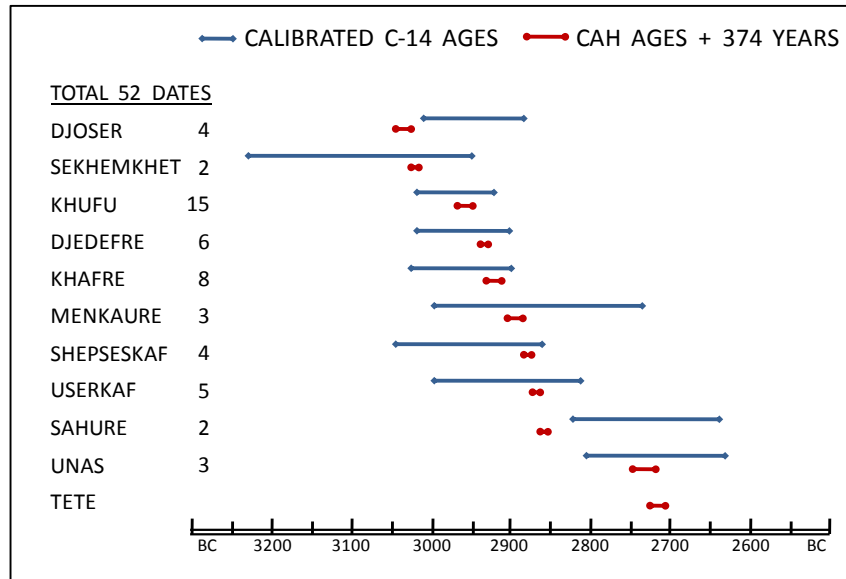

Fig. 21. Offset between the averaged ^{14}C dates of Haas and those given in the *Cambridge Ancient History* (CAH) for various pharaohs of the 3rd through 6th Dynasties. Note that the CAH dates have been shifted back 374 years to align with the ^{14}C dates. Adapted from Haas et al. (1987: 601, fig. 2).

and horsebeans, and they were measured at three different laboratories.⁴⁶ The dates were averaged in their uncalibrated BP form, producing a date of 8790 ±50 B.P. From this number was subtracted 1950 to produce an uncalibrated date of 6840 ±50 B.C.E., a date that was considered to be "in accordance with that of other similar Neolithic villages in the central and southern Levant" (Garfinkel, Carmi, and Vogel 1987: 42). However, when these dates are calibrated and then averaged, the result is 7924 B.C., nearly 1,100 years earlier than the uncalibrated date and thus not "in accordance" with the dates approved by the authors.

Newgrosh (1992) has noted a persistent difference between radiocarbon dates (especially calibrated ones) and historically derived dates, amounting to about 400 years around 2000 B.C. and about 1,000 years around 4000 B.C. The error is suggested to be in the calibration curve and in the dendrochronologies, which have issues of autocorrelation, circular reasoning, and both cumulative and catastrophic error.

In 2001, Bruins and van der Plicht published the results of new ¹⁴C tests on materials from Jericho that had been recovered by Kenyon's excavations in the 1950s. The eight samples were mainly short-lived, charred grain. Two were rejected as outliers. These dates were also compared to the contemporaneous Egyptian periods (Dyn 1-6). Based on the ¹⁴C determinations, the authors suggested extending the EB I-III back by something like three centuries (fig. 22). "Most ¹⁴C dates overwhelmingly show that these

⁴⁶ Weizmann Institute of Science, Rehovot, Israel; National Physical Laboratory, Pretoria, South Africa; Université Claude Bernard, Lyon, France.

periods are significantly older than currently accepted" (Bruins and van der Plicht, 2001: 1331).⁴⁷

Braun (2001) also notes that acceptance of ¹⁴C values would lengthen the EB I by up to 450 years, although there is no corroborating evidence that would allow for such a shift. Highlighting the uneasiness of this situation, he states that "the logical outcome of

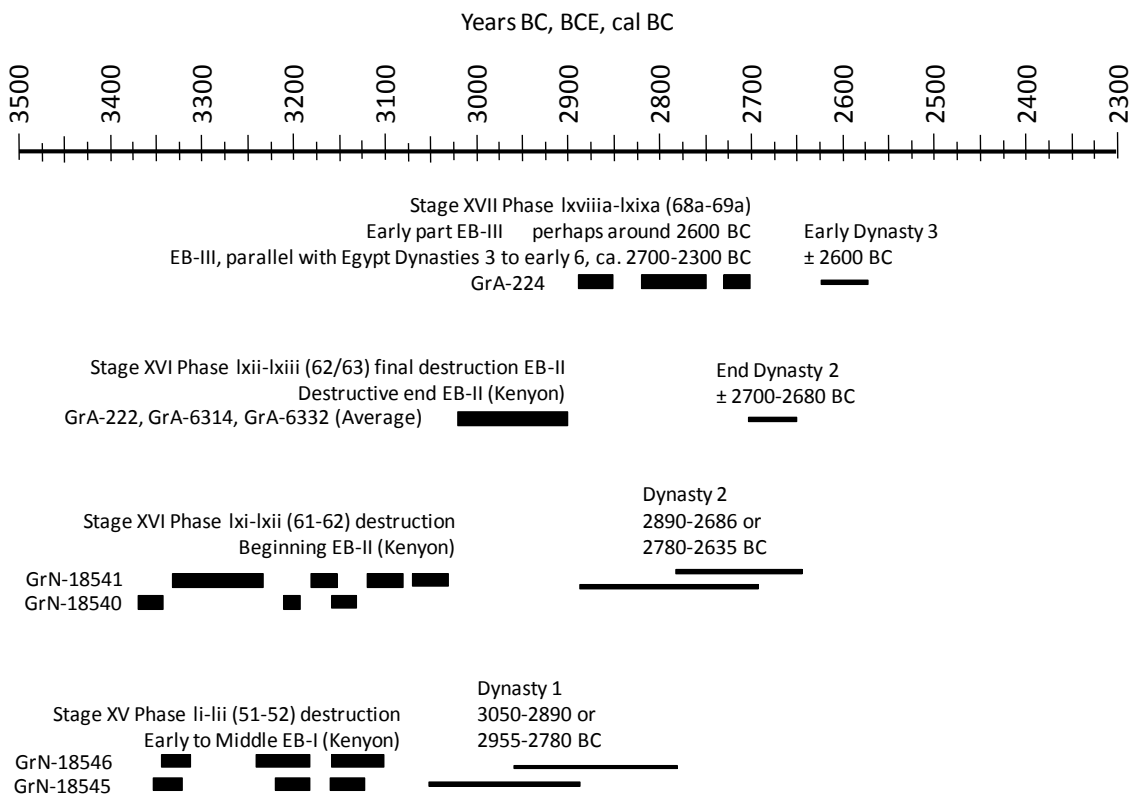

Fig. 22. Offset between ¹⁴C dates and archaeo-historical age assessment (Bruins and van der Plicht 2001: 1330, fig. 3).

⁴⁷ Bruins and van der Plicht also suggest that the date for the beginning of the Chalcolithic Period has receded by 1,000 years in the last century or so, based solely on ¹⁴C dating (2001: 1330).

the acceptance of these new dates puts such a strain on chronological correlations between the ^{14}C data and the archaeological record that the entire system would no longer be tenable if they were accepted" (2001: 1279).

In light of the mismatch between the historical chronology and the radiocarbon results obtained by Haas in 1984, a new set of samples was collected from the Giza Plateau area in 1995 that were intended to confirm, adjust, or retract the differences (Bonani et al. 2001). Of the 353 samples collected, 166 were submitted for ^{14}C dating. After processing, the removal of outliers, and averaging, the dates were matched against the historical dates. Weinstein considered these results to be "much more in line with the conventional historical chronology" (2003: 643). This may be true in comparison with the original results of Haas (1987), but two other observations are equally true. First, the results obtained by Bonani et al. are still, on average, too early by about two centuries, although the results are somewhat mixed. They may be closer to the historical dates overall, but they are still significantly earlier. Secondly, it is clear that the ^{14}C results are not capable on their own of placing the historical events or people in the correct order (fig. 23).

The results from Tel el-Dab'a show a consistent off-set between ^{14}C and historical dates, with the ^{14}C being earlier (fig. 20). "With the end of LM IA [Late Minoan, equals Egyptian New Kingdom Dynasty 18] we arrive at a dating difference of 120-130 years" (Bietak and Höflmayer 2007: 20). A similar offset had been noticed decades earlier by Kemp. He noted that dates from New Kingdom contexts have a tendency "to be too high, by over a century, frequently by two" (Kemp 1980: 27). Regarding a set of 25 New Kingdom determinations, "11 may reasonably be said to be consistent with accepted

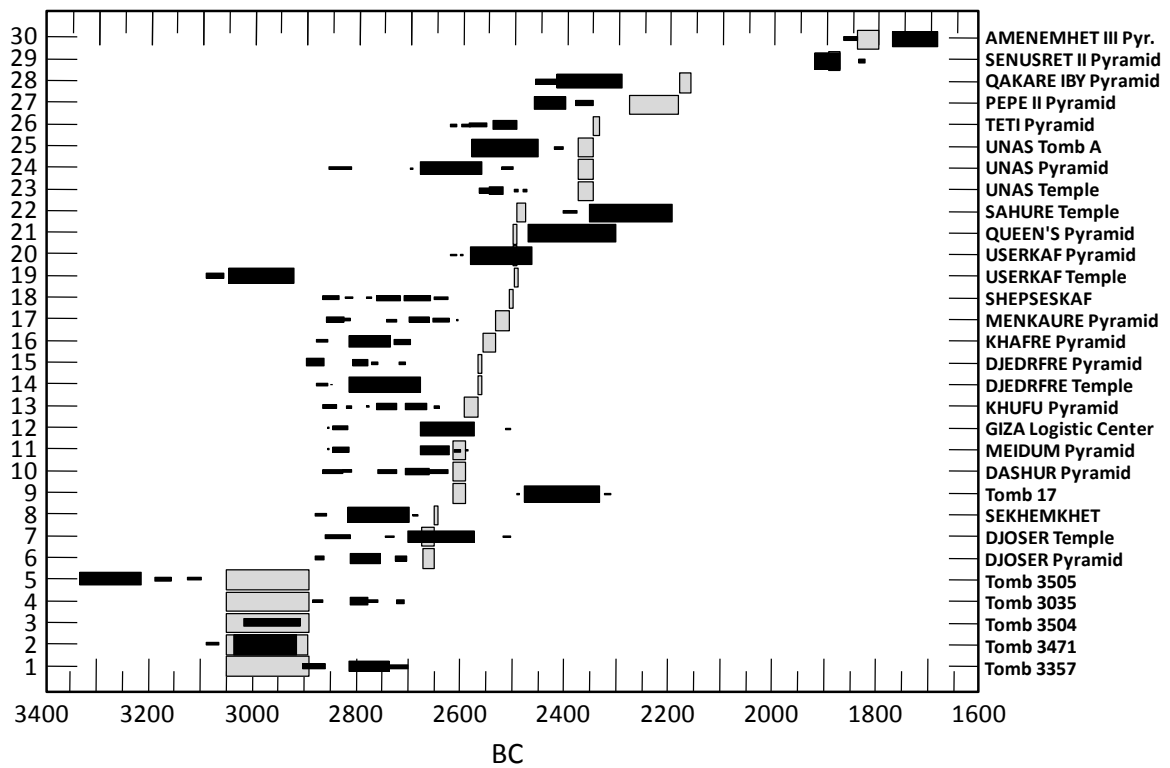

Fig. 23. Offsets of calibrated 1σ ^{14}C dates (black bars) with historical dates (grey areas), after Bonani et al. (2001: 1300, fig. 1).

dates, and 14 to be inconsistent by amounts ranging from about 100 to 400 years, always on the early side" (Kemp 1980: 27; see fig. 24). Middle Kingdom and especially Old Kingdom dates are not very solid in Egyptian chronology, being based on estimations of periods where data are sparse, but for the New Kingdom the data are plentiful and the historical chronologies are quite tight. As Bietak rightly notes, stretching the dates for the beginning of the New Kingdom by a century is completely out of the question from an archaeological/historical perspective. As he concludes, "This shows that the major reason (or fault) for this offset cannot be blamed on historical chronology" (2007: 20).

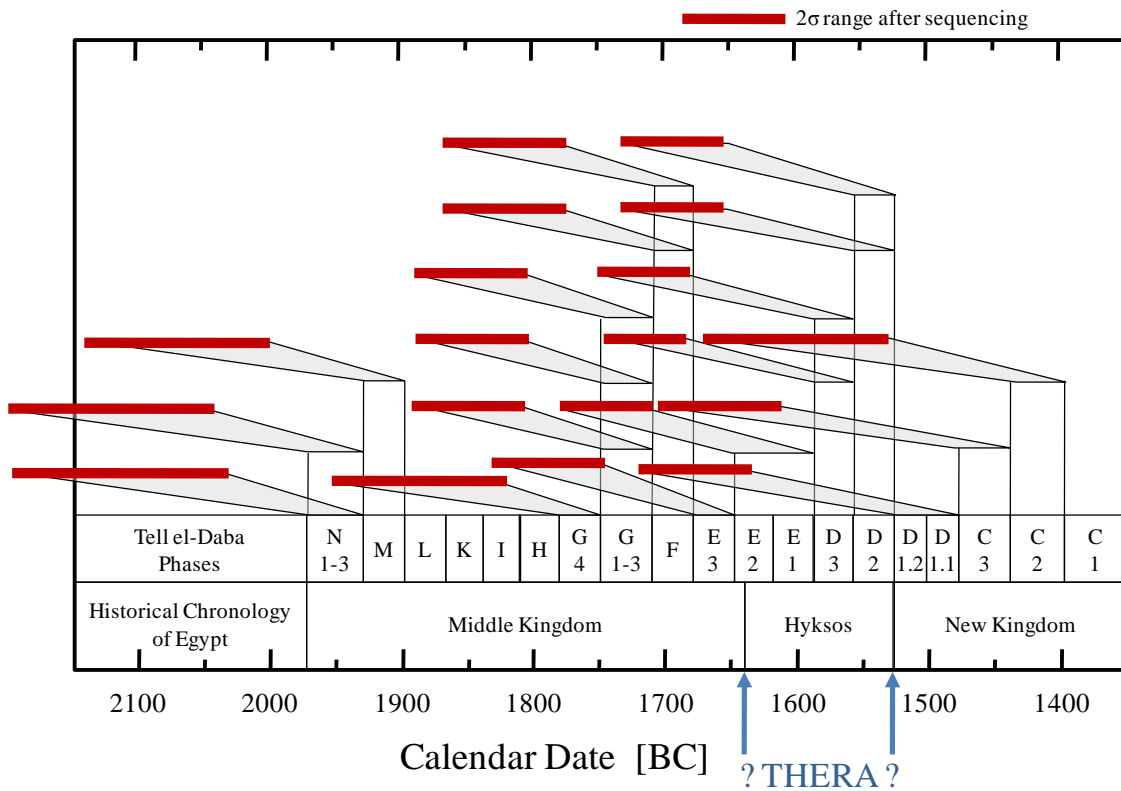

Fig. 24. Offsets between ^{14}C and historically derived dates from Tell el-Dab'a (Bietak and Höflmayer 2007: 14, fig. 1).

Why are the ^{14}C dates so early? In some cases it is possible, of course, that the historical/archaeological dates are incorrect, as suggested by some (e.g., Callaway and Weinstein 1977; Mellaart 1980; Haas et al. 1987; Bruins and van der Plicht 2001). No suggestions have been made, however, as to where or how the historical chronologies could be so badly in error. For the Egyptian periods back through the New Kingdom, the dates are firmly fixed by numerous historical records including reign lengths, astronomical data, and foreign synchronisms and are not subject to significant lengthening. Earlier periods are less fixed by historical data, but even there it is difficult to believe that lengthening the periods by centuries is feasible.

The other possibility is that radiocarbon is the source of error. But where might the error be located? Newgrosh (1990) has observed that radiocarbon dating has been used in the construction of the bristlecone pine chronology, thus it is circular to argue that it can then be used for calibration as well (so also Kutschera and Stadler 2000: 71). He also notes that there are known problems with pretreatment techniques, but it is assumed that these do not amount to more than 2-3 radiocarbon years. One interesting suggestion for explaining how the radiocarbon estimates could be so far off has been put forward by Keenan (2002). He cites evidence that the deep waters of the Mediterranean underwent stagnation following the ice age. When that water finally began to be remixed, starting around 4000 B.C. and ending perhaps around the turn of the era, it released large amounts of CO₂ into the atmosphere that had much lower levels of ¹⁴C. This would have happened primarily during the winter growing season and would have affected the regions downwind from the Mediterranean. Keenan points to several modern examples where this kind of phenomenon has been documented, albeit on a smaller scale. He concludes that "the hypothesis is plausible, and further research is required to verify or refute it. It would be ironic if the 'cradle of civilization' turned out to be in just the right place and time to make its ¹⁴C dates erroneous, but that might be the case" (Keenan 2002: 231).

Another observation that may explain some early offset, at least in Egypt, is that an offset (winter) growing period may cause lower and thus older ¹⁴C dates. Ramsey follows earlier studies in concluding that this may amount to as much as a 20-year error for New Kingdom dates (Ramsey et al. 2010: 1555). However, this is a fairly minor offset compared to the large amounts that have repeatedly been found in other studies

(Table 1). There are certainly ^{14}C determinations that fall on the more recent side of historical chronologies as well, as one might expect.⁴⁸ However, there is a clear and strong tendency for them to fall on the earlier/older side, and the tendency seems to become more exaggerated as one moves back in time.

Table 1. Sample offsets for various ANE sites and periods.

Site	Period	# of dates	Approx. Offset	Source
Deir 'Alla	IA IB	3	350	Weinstein 1984
Tel el-Daba'	New Kingdom	18	125	Bietak and Höflmayer 2007
Giza Plateau	Old Kingdom	166	200	Bonani et al. 2001
Pyramids	Old Kingdom	6	300	Bruins & van der Plicht 2001
Pyramids	Old Kingdom	80	375	Haas et al. 1987
Numeira	EB III	5	450	Weinstein 1984
'Ai	EB III	2	600	Weinstein 1984
Bab edh-Dhra'	EB III	5	600	Weinstein 1984
Jericho	EB III	12	300	Weinstein 1984
Jericho	EB III	1	200	Bruins & van der Plicht 2001
Jericho	EB II, late	4	250	Bruins & van der Plicht 2001
Jericho	EB II, middle	1	350	Bruins & van der Plicht 2001
Jericho	EB II, early	2	300	Bruins & van der Plicht 2001
Afridar	EB I	12	200	Braun 2001
Mesopotamia	Ubaid/Uruk	numerous	1,000	Hole 1987
Yiftah'el	PPNB	6	1,100	Garfinkel et al. 1987

Note. The offsets presented here are averages of the number of dates presented; all offsets are on the early side of the historical chronologies.

⁴⁸ A recent example is the set of three ^{14}C dates from Har Hemar. The site exhibits only EB II-III ceramics, dated by the excavators to about 2700 BC, yet the radiocarbon dates all centered in the 9th century BC. This extraordinary result led Yekutieli to suggest a brief visit by Iron Age people who scraped the rooms of the site clean of pottery, dumped the pottery on the northern slope of the site, built a brush fire between some of the houses, toppled in the remaining walls, and erected a small standing stone on the debris. "It is remarkable that without the radiocarbon evidence this event would have been totally invisible" (Yekutieli 2009: 233). It may be even more remarkable that such a bizarre scenario could be recreated and published on no more solid evidence than three ^{14}C dates.

Manning (2006) has suggested that there really is not, in fact, an age issue with radiocarbon dating, particularly in Egypt. He attributes the appearance of an age discrepancy to the “old wood” effect. It is possible that this explanation works for some samples, although it is difficult to prove. On the other hand, two recent samples on (short-lived) human hair from New Kingdom tombs produced ^{14}C dates that were over a century too old (Hassler and Höflmayer 2008), consistent with the discrepancy noted on other (long-lived) samples.

^{14}C Dates Too Inconsistent

It has long been known that radiocarbon determinations for items originating from similar or even identical strata are commonly inconsistent, sometimes wildly so. Only a few examples are given below for the sake of illustration, but the problem of inconsistency among ^{14}C dates that should be similar is widespread.

In 1977, Callaway and Weinstein wrote an article in which they attempted to synthesize all the then-known radiocarbon dates for the Early Bronze Age (EBA). A total of 55 dates was available for the EB at that time. Of those, at least 25 were rejected because they were viewed as "aberrant," "deviant," "unacceptable," "inconsistent," or "unreliable." Despite the fact that "this 45% rejection rate is very high and obviously quite disappointing," the remaining acceptable dates were subsequently used to argue for a higher/earlier chronology for the EBA, on the order of a century higher for the EB III and perhaps more for the earlier periods (Callaway and Weinstein, 1977: 11-12).

Weinstein's 1984 study included 474 ^{14}C determinations. Weinstein found evidence of numerous problems with dates across the spectrum, some of which he

characterized as "systematic misdating of entire series of samples" (1984: 312). In addition,

the Bab edh-Dhra' and Numeira dates present some interesting problems. For example, the entire series, SI-4132 to -4138, is anomalous. SI-4134 and -4135 from Bab edh-Dhra' are more than 1000 years off. SI-4136 and -4138, which come from late EB III destruction debris at Numeira, are several hundred years too early to pertain to the end of EB III, though they could certainly reflect the dating of early growth rings of older wood. As for SI-4137, the date, which is 500 to 600 years too old, comes from grapes which were collected in a water flotation device. (1984: 308)

Grapes, of course, are a short-lived sample that would not be susceptible to "old-wood effect" or inbuilt age.

Braun (2001) compared numerous ^{14}C determinations from EB I-II sites and from early Egyptian sites (mainly Dyn 0-2). He discovered numerous inconsistencies. For example, a date from EB I Hartuv would make it contemporaneous with Beth Shemesh Stratum IV, although it clearly belongs to an earlier cultural horizon (2001: 1285).

Three radiocarbon measurements were made in the early 1960s on a reed mat found in the Cave of the Treasure in Israel. Related items place the stash of articles in the Chalcolithic period. In 1999 and 2000, six additional radiocarbon determinations were made on material from the mat. Aardsma contrasted these six new ^{14}C dates with the three previous determinations (fig. 25). The material is all short-lived, but the combined results, when calibrated, at the 1σ confidence level, span more than 1,300 years. The six new determinations alone span some nine centuries, with the three younger dates not overlapping the three older dates at the 1σ confidence level. One possibility suggested by Aardsma was that the mat was repaired in antiquity, although he rejected this possibility as highly unlikely based on the way the mat was woven. His preferred explanation, which seems even more absurd, is that the reeds were kept separately (unwoven) for

centuries before being woven into a mat, with a few new ones being inserted just prior to weaving.

More recently, Higham et al. evaluated a series of radiocarbon determinations from Kirbat en-Nahas. Of the 15 dates from Area A, six "were eventually excluded due to low agreement indices. This model [using the remaining nine dates] produced a final acceptable agreement index of 78.6%" (Higham et al. 2005: 170). In Area S at Kirbat en-Nahas, 3 of 19 were excluded as too old and thus not acceptable. This is three times the expected failure result of 5% (Higham et al. 2005: 172). Using the remaining 75% of the radiocarbon determinations, the authors used Bayesian modeling to weight, sort, and

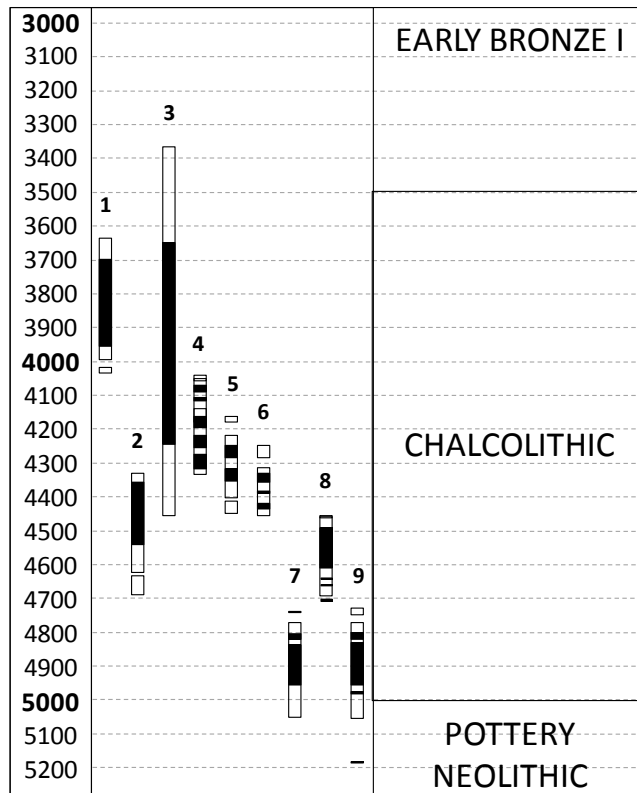

Fig. 25. Radiocarbon determinations from the reed mat from the Cave of the Treasure; numbers 1-3 are the original determinations, 5-9 are the newer determinations. Adapted from Aardsma 2001: 1248, fig. 1.

average the remaining data. "Taken together, the Bayesian analysis sharpens the available chronometric data considerably" (Higham et al. 2005: 172). By way of explanation for the rejection of 9 out of 36 determinations, the authors suggest that the aberrant determinations were "almost certainly influenced either by taphonomy and mixing within the confines of the site, or are affected by inbuilt age" or old-wood affect (Higham et al. 2005: 172). The fact that two possible explanations are given is evidence enough that the true reason is not known, and the excluded dates were set aside not because of a known contamination issue but solely because they were inconsistent with the expected outcome.

Shaw had already addressed the possibility of averaging dates some 20 years earlier.

Given a large number of radiocarbon dates from a particular historical period, it is naturally tempting to use weighted averages to synthesize the data into a coherent chronology. But the phenomenon of inter-laboratory bias and the more serious fact of the different methods used in assessing error in dates mean that the results of such syntheses (even if the F-test of contemporaneity is applied) are potentially misleading. The use of weighted averages can create an illusion of certainty. (Shaw 1985: 301)

Yet another example is provided by Bruins (2004: 95). He suggests that a 2σ date for sheep or goat bone at 1189-915 B.C. (± 274 yrs) constitutes the first scientific evidence of IA occupation at Horvat Haluqim. He then mentions two charcoal samples from the site, one with a 2σ determination at 896-519 B.C. and another at 1σ A.D. 262-659. The latter is assigned to the Roman/Byzantine period (and an associated watchtower), while the former "is a surprise in archaeological terms" as there are no associated buildings or pottery from the late IA. He explains that "even if the charcoal fleck (GrA-12448) is the result of a camp-fire from passers-by in the later Iron Age, which did not add another living floor or stratum to some of the earlier Iron Age

buildings, it is still a witness of past human activity at the site." This almost comes off as an effort to rescue the radiocarbon system from looking irrelevant.

More directly related to the region and time period for Bab edh-Dhra' and Numeira, a couple of EB IV radiocarbon dates have been produced for the nearby site of Khirbet Iskander. These were then compared with a set of five radiocarbon determinations from Bab edh-Dhra' (fig. 26). The date range for the first Khirbet Iskander reading, after calibration, was 2571-2462 B.C. (1σ). The second sample produced a slightly younger and somewhat broader range at 2549-2307 B.C. (1σ). As the author notes, "This is a relatively high date for EB IV. . . . Since this sample is from no earlier than Phase 2 of Area C, it does appear to be early" (Holdorf 2010: 267). Holdorf

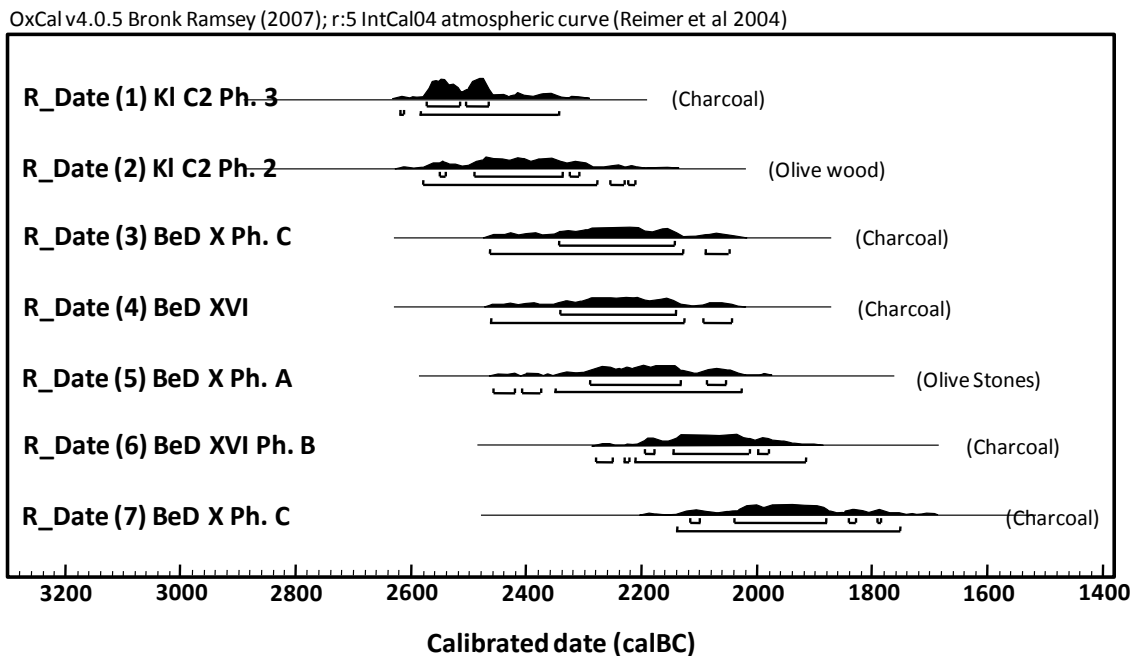

Fig. 26. Radiocarbon determinations from Khirbet Iskander, compared to radiocarbon determinations from Bab edh-Dhra'. After Holdorf 2010: 270, fig. 15.3.

is fairly quick to blame the earliness of these dates on “old-wood” effect, going so far as to state that “using C₁₄ samples that are or may be from wood is unlikely to be helpful in correlating phases of a 400-year age, either within a site or between sites.

Regarding the issue of consistency, it should also be noted that the seven dates from Khirbet Iskander and Bab edh-Dhra’ (which have already been purged of outliers in the case of Bab edh-Dhra) span a period of over 800 years at the 2σ level.

It is unfortunate that the shortcomings of radiocarbon dating are not more commonly acknowledged. Certainly they are known. Hankey (1987: 55) notes that “radiocarbon age measurements are not truly dates, but statements of probability.” He observes that “Christopher Chippindale, the new editor of *Antiquity*, is more precise in his uncertainty, ‘a radiocarbon determination is not a date, but a measure of time subject to complex statistical variability in the light of a wiggly calibration curve of radiocarbon “years” against real elapsed time.’” Likewise, Manning has acknowledged that “routine radiocarbon dating and calibration are not straightforward, and are governed by inherent biases and preferences” (1995: 136).

In some ways the archaeologist who chooses to collect ¹⁴C already places himself in a difficult spot. What should be done with the data? On the one hand, 2σ ¹⁴C ranges are “enough greater to make them less adequate for archaeological use” (Ehrich 1992: vii). On the other hand, 1σ ranges only have a 2/3 chance of including the real date of the sample (assuming no other problems), causing some scientists to recommend *only* the use of 2σ dates, especially with routine dates (e.g., Baillie 1983: 60). In fact, Weinstein suggests that “¹⁴C samples should not be collected from Middle Bronze age or later contexts unless the archaeologic dating evidence is inadequate (e.g., in the case of a

furnace or slag heap unaccompanied by any pottery or inscriptions)" (Weinstein 1984: 312).

One partial explanation for some inconsistency in ^{14}C determinations is that variations have been observed in readings from different species of trees and from trees growing in different hemispheres. A recent study of hemispheric differences found an offset of 27.2 ± 4.7 years for the interval A.D. 1725 to 1935 (McCormac et al. 1998: 1156). This is similar to other studies cited by McCormac for hemispherical differences. McCormac also cites several other studies that show regional differences within the same hemisphere and notes that "these authors have suggested that regional effects may not be temporally constant" (McCormac et al. 1998: 1153). It may be observed that these offsets can be discovered only because the dendrochronology for these recent periods is unquestionable. But how are such offsets to be discovered in ancient periods where tree-ring sequences are not available, or for samples that come from short-lived plant or animal remains? "Can we really apply the tree-ring calibration of radiocarbon activity to the radiocarbon activity in other materials? This question used to be asked in the early years of radiocarbon dating and is worth asking again" (Newgrosh 1990: 40).

A recent critique of radiocarbon dating has noted that "recent years have seen major progress in the science and art of radiocarbon dating. . . . Within the past decade, however, high precision laboratories have sometimes provided quite different date ranges for materials divided between them, as in the case of the reported dates a century apart for the Turin Shroud as well as for the control material of known first century B.C./A.D. date" (Wiener 2007: 29-30).

In order to illustrate the inability of ^{14}C to resolve major questions of chronology, we will now examine two test cases. The first is from the Iron Age, the second from the MB/LB. In both cases there are numerous ^{14}C determinations available for the site or event in question.

Iron Age Test Case—Tel Rehov

Among the many sites where ^{14}C has played a role in the discussion of chronology, probably none has figured more prominently in recent times than the Iron Age site of Tel Rehov, excavated by Amihai Mazar. Much of the controversy over the chronology of the Iron Age, with a low scheme favored by Finklestein and a higher scheme favored by Mazar, has centered around the excavation results from Rehov. Initial ^{14}C results (20 from Tel Rehov along with another 33 from Beth Shean) were considered by Mazar to be in general agreement with historical dates, although he acknowledged that the ^{14}C results were ambiguous enough that they could not be used to definitively settle the Iron Age chronological debate (Mazar 2001b). As usual, a number of dates were rejected for yielding "unrealistic" dates, this time from area D at Rehov. It was also noted that using different calibration curves can give significantly different results. The two employed by Mazar were the 1993 and 1998 curves (Mazar 2001b: 1339), although he noted that future changes in the calibration curve could affect the results.

In 2003, Mazar and others published another article on ^{14}C and Rehov. This time the ^{14}C results from different strata were combined to produce a weighted average, which was then wiggle-matched to fit the ^{14}C calibration curve (fig. 27). The rationale for wiggle-matching is that "the horizontal range of the calibrated date is determined by the calibration curve but conditioned by the stratigraphic order, because most layers cannot

overlap in time, but succeed each other" (Bruins, van der Plicht, and Mazar 2003a: 317). Thus, the wide 1σ ranges for individual weighted averages are reduced so that all the strata can be fit together in the necessary sequence and within the necessary historical timeframe without overlapping.

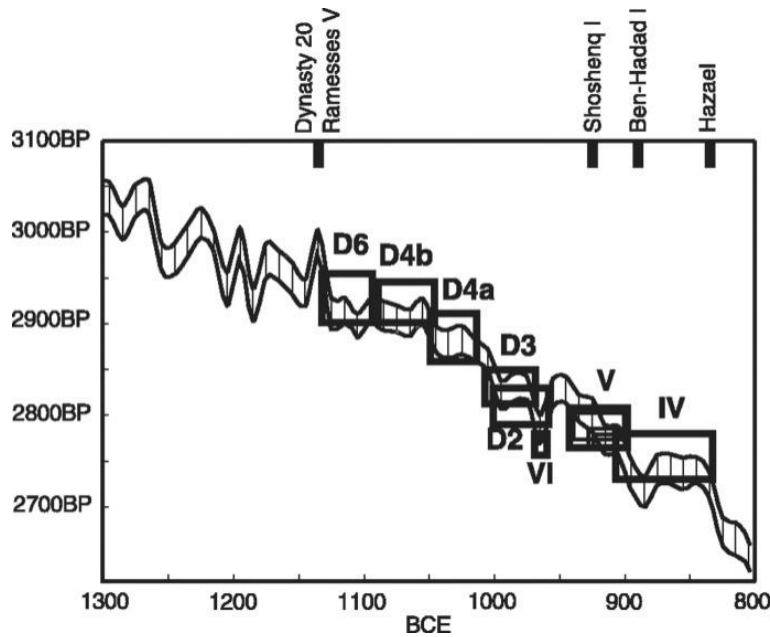

Fig. 27. Initial placement of strata from Tel Rehov on the ^{14}C calibration curve according to Bruins, van der Plicht, and Mazar 2003a: 317.

Finklestein and Piasezky responded that the ^{14}C data could as easily be interpreted to fit with the low chronology. By shortening Stratum V, he was able to wiggle-match Stratum VI with a lower section of the calibration curve, thus concluding that the Tel Rehov data do not contradict the low chronology (fig. 28).

Bruins, van der Plicht, and Mazar responded by publishing yet another chart, this time showing the ^{14}C results in their full 1σ form, using the results to argue that

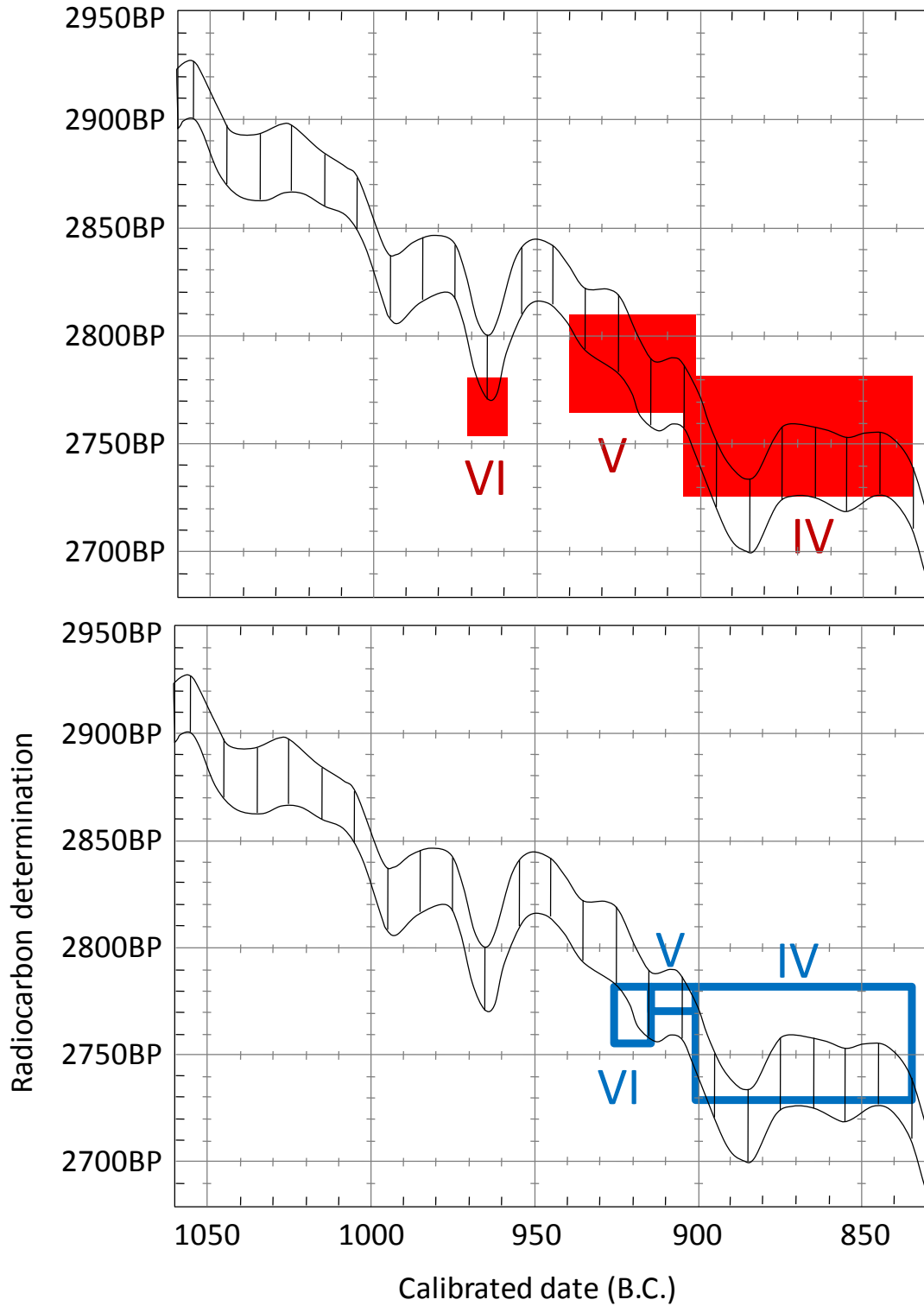

Fig. 28. Comparison of Mazar's initial placement (red) with Finkelstein's revised placement (blue) of ^{14}C dates for Tel Rehov (after Finkelstein and Piasezky 2003: 568b).

squeezing Strata V and VI together so tightly is unrealistic (fig. 29). Yet this chart is also misleading, for two reasons. As noted by the authors, the respective 1σ ranges are centered around the BP midpoints for graphical clarity and to prevent vertical overlap. Thus they are represented as being narrower than is actually the case. Secondly, the chart does not indicate the true contact points between each calibrated ^{14}C determination and the calibration curve. For example, the weighted average sample from Stratum VI should actually have four contact points with the calibration curve, not just two (fig. 30).

It should be clear that ^{14}C is not sufficiently free of subjective interpretation that it can resolve this dispute over Iron Age chronology. The wiggly nature of the calibration curve and the width of even 1σ ^{14}C determinations prevent fine chronological resolution. The two sides in this argument are still a century apart, unable to come to an agreement despite dozens of ^{14}C determinations from controlled contexts.

MB/LB Test Case—Thera

Another date which has been vigorously contested is the eruption of the island volcano of Thera, sometime toward the end of the MB or start of the LB. Radiocarbon determinations place the eruption during the 17th century B.C., with 1628 standing as one of the most commonly cited dates (e.g., Kuniholm 1996: 782; Bietak and Hein 2001: 174; Porter 2005: 43) due to the appearance of a particularly harsh winter in many of the dendrochronologies in that year, an event that could have resulted from volcanic ash lowering global temperatures.⁴⁹ The situation is complicated, however, by the fact that the radiocarbon calibration curve at this point is flat, making it impossible to produce ^{14}C

⁴⁹ Another range of dates, from 1627 to as late as 1480, is provided in chart form in Kutschera and Stadler (2000: 73, Table 1).

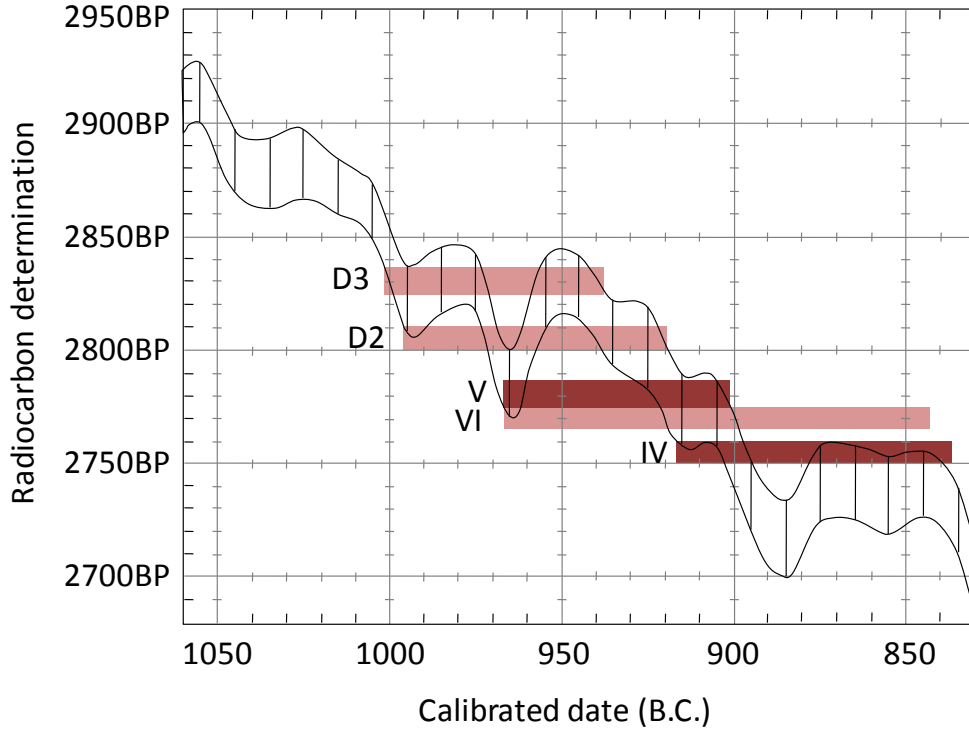

Fig. 29. Response by Bruins, van der Plicht, and Mazar (2003b: 568c) with broader ^{14}C bands.

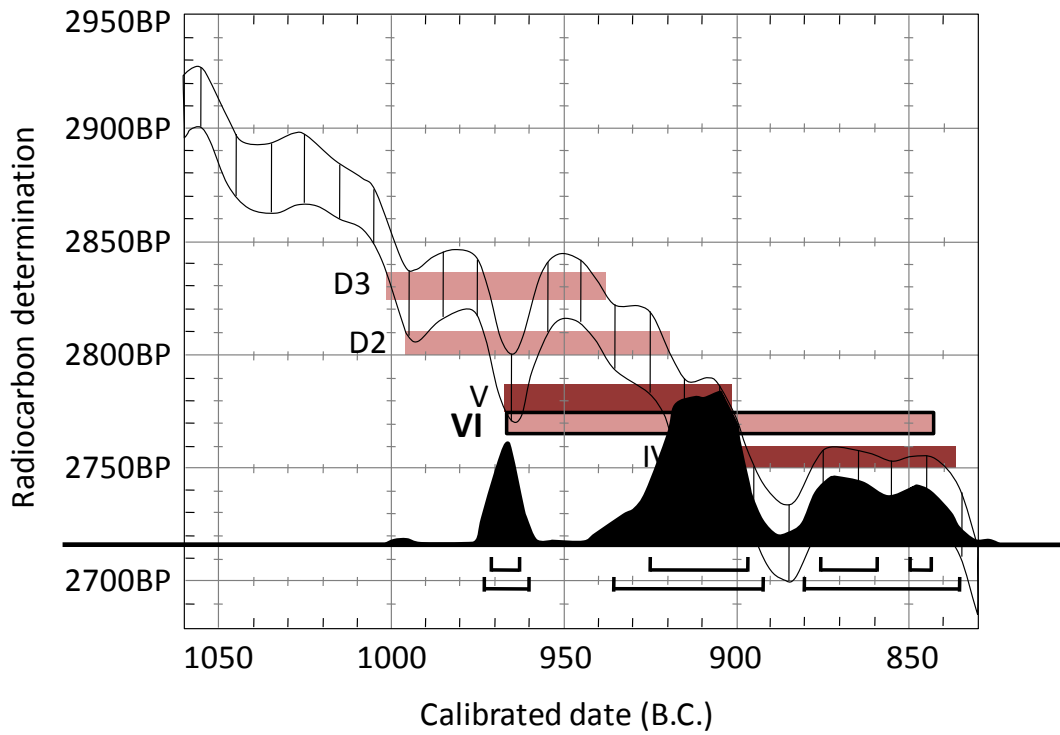

Fig. 30. Actual range of the weighted average for ^{14}C from Area C Stratum VI, Locus 4426 at Tel Rehov (Bruins, van der Plicht, and Mazar 2003a: 316, fig. 2), spanning nearly two centuries, overlaid on the previous chart.

dates that are precise. Kutschera and Stadler give an averaged set of 25 dates from the destroyed city of Akrotiri on Thera which render two major ^{14}C date ranges in the 1σ range, while the 2σ range spans 1680-1520 B.C. (fig. 31).

For a time it was thought that an acid peak in Greenland ice-cores that appeared in 1645 was likely due to Thera. However, more recent analysis of the volcanic glass in this layer has shown that the 1645 event was definitely not Thera, but rather the eruption of the Alaskan volcano Aniakchak (Pearce et al. 2007: 140). In fact, volcanic ash from Thera has not yet been positively identified in any ice-core samples.

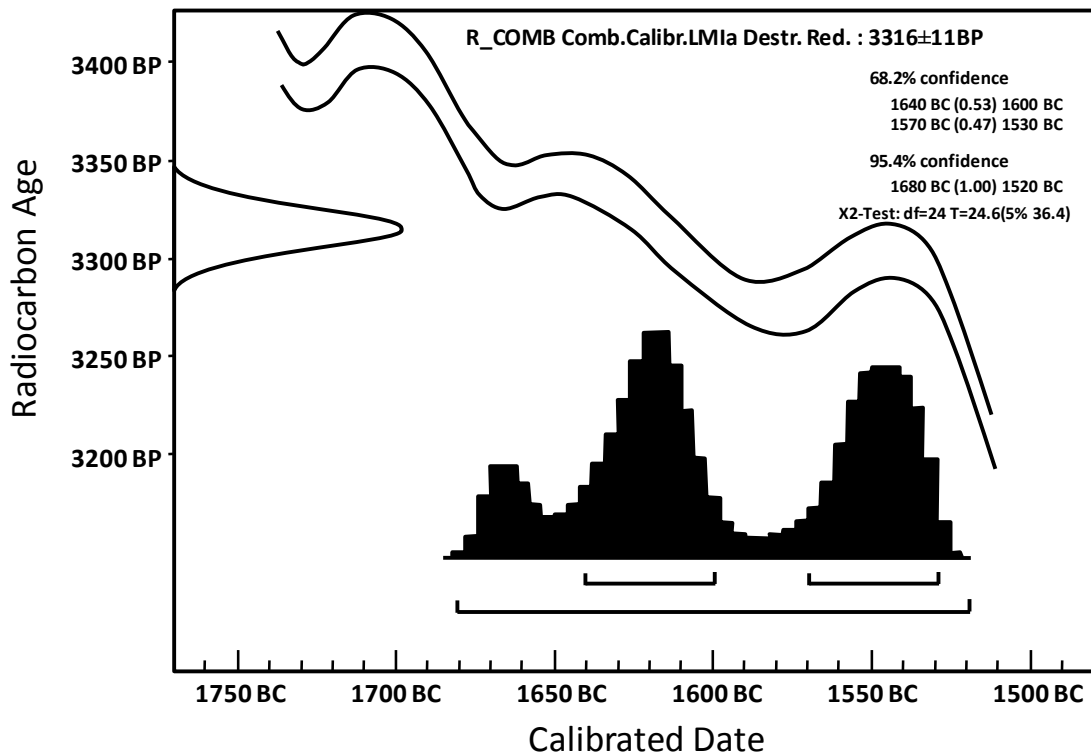

Fig. 31. Averaged date ranges of 25 radiocarbon determinations from Akrotiri, showing the effect of the flat calibration curve for this period (after Kutschera and Stadler 2000: 77, fig. 2).

Archaeological evidence, on the other hand, places the Theran eruption much later than the radiocarbon determinations, perhaps around 1500. Much of this evidence comes from the excavations of Bietak at Tell el-Dab‘a.

1. *Cypriot White Slip (WS) ware*—A milk-bowl of this type was found at Akrotiri in 1870 *beneath* the Theran destruction level (Viennaer 2001). This pottery has been found in 18th Dynasty levels at Ajjul, Hebwa, Ashkelon, and Naami (Porter 2005: 45; Bichler et al. 2003: 13). At Tell el-Dab‘a this pottery does not occur until after stratum D/2 or the beginning of the 18th Dynasty, leading to the conclusion that “the eruption must have happened, therefore, not before the beginning of the New Kingdom” (Bietak and Hein 2001: 172).

2. *Minoan paintings*—Plastered wall paintings in the Minoan style have been found at el-Dab‘a in large quantities. The subject of one panel is a bull-leaping scene much like one found at Knossos. Similar components have been discovered in the debris of the period immediately before the Theran eruption at Akrotiri (Late Minoan IA) (Kutschera and Stadler 2000: 71). These paintings at Tell el-Dab‘a are dated to the beginning of the 18th Dynasty (Stratum C). Based on the similarity in style and motif, “the paintings at Thera should be roughly contemporary” (Bietak 1996: 76).

3. *Theran pumice*—Pumice from the Theran eruption was found at el-Dab‘a, apparently carried there by the sea. The pumice was collected and used as an abrasive in workshops. “Its chronological context at Tell el-Dab‘a within a single restricted stratum of the New Kingdom dates it to sometime after the reign of Ahmose and before that of Thutmose III (c. 1500 BC)” (Bietak 1996: 78). In this regard el-Dab‘a is not alone, as

Theran pumice has also been found on top of Second Intermediate Period levels at Tell el-Habwa in Northern Sinai (Bietak 1996: 78, Bichler et al. 2003).⁵⁰

Taken together, the WS1 pottery, Minoan-style paintings, and Theran pumice all show that the Theran eruption should be dated, from an archaeological/historical perspective, to about the beginning of the New Kingdom in Egypt.

If we were to adopt the more recent high chronology for the Santorini (Thera) explosion at about 1628 BC, based on radiocarbon and dendrochronology, we would have to raise the dates of Egyptian chronology by some 130 years. Apart from the serious problems this would cause to the Egyptian chronological framework and astrochronology, we would have to fill 130 years of Egyptian history. Currently no Egyptologist would accept such a proposition. (Bietak 1996: 76; cf. Bietak 2003b)

As Kitchen has succinctly stated, “Any idea of slipping in the odd extra century or so to link up (e.g.) with supposed dates for the Thera eruption can be resolutely and definitively dismissed” (Kitchen 2000: 44). “The apparent discrepancy between the historical date of Thera and the one suggested by various dating methods within the realm of Natural Science is clearly disturbing” (Kutschera and Stadler 2000: 72).⁵¹ The discrepancy is clearly illustrated by Bruins (fig. 32), although Bruins does not adequately reflect the stretching effect that the radiocarbon results would have on the Egyptian historical chronology.⁵²

⁵⁰ See also the list provided by Porter (2005: 45) that includes 18th Dynasty levels at Ajjul, Hebwa, Ashkelon, and Naami, although some of the evidence is still unpublished.

⁵¹ Lasken (1992) regards the radiocarbon dates from Thera as anomalous, partly because readings from long-lived samples are later than those from short-lived samples. The suggested reason is that the short-lived plants took up volcanic gasses that gave them much older readings. However, almost all studies have preferred the short-lived samples over the long-lived, arriving at a date for the Theran eruption between 1700 and 1500, whereas Lasken prefers the most recent of the short-lived samples, opting for a date between 1200 and 700 BC.

⁵² For example, the dividing line between phase D2 and D1.1-2 (destruction by Ahmose) should match the division between the SIP and the New kingdom, not the middle of the SIP, while the division between phases L and K (year 5 of Sesostri III) should fall in the middle of the 12th Dynasty. For detail, see Bietak and Höflmayer 2007: 15, fig. 2, as seen in figure 33 below.

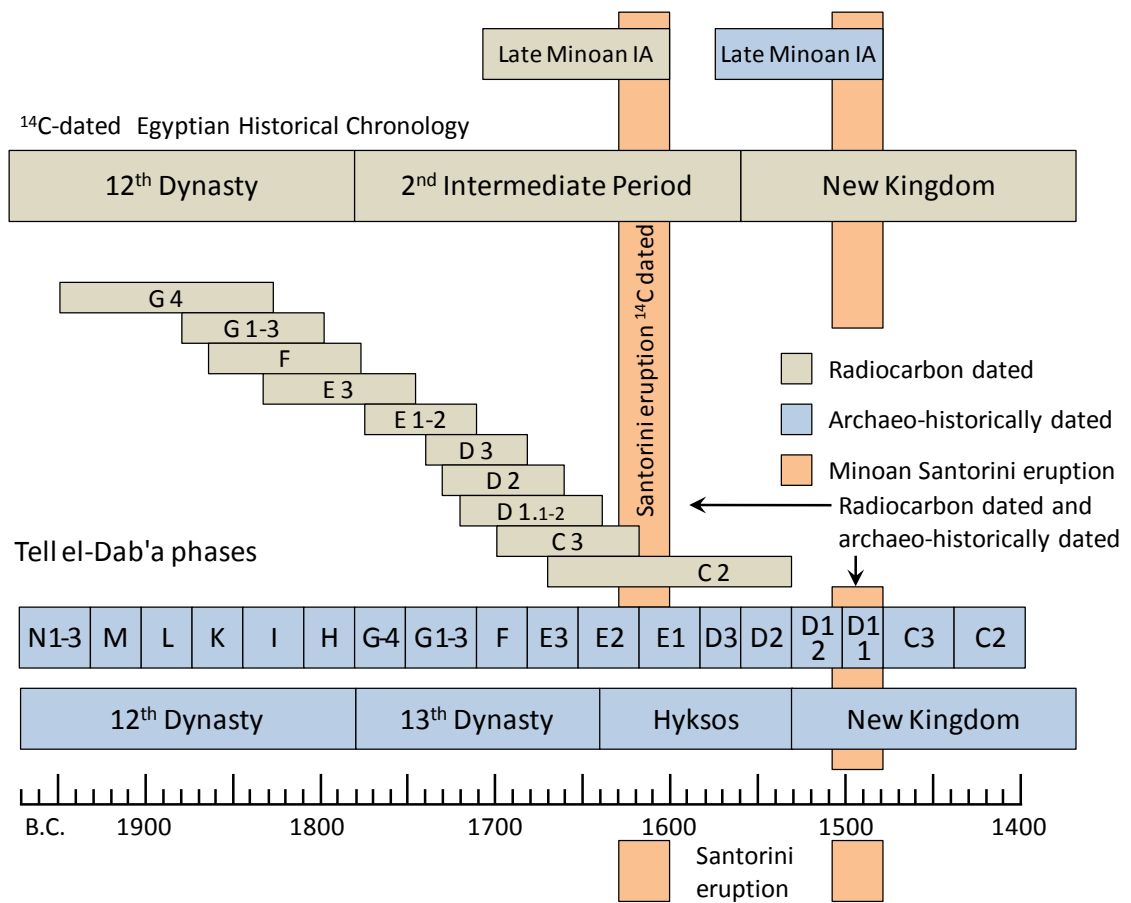

Fig. 32. Illustration of the differences between radiocarbon-derived dates and archaeo-historically derived dates, showing (1) Radiocarbon dating (brown) and archaeo-historical dating (blue) of the Late Minoan IA period; (2) Radiocarbon-based Egyptian chronology; (3) Radiocarbon-dated archaeological phases at Tell el-Dab'a; (4) Archaeo-historically dated phases at Tell el-Dab'a; (5) Historically based Egyptian chronology; adapted from Bruins 2010: 1490.

In contrast to the Iron Age debate over Rehov, in the case of Thera there is really not a debate between historians. The debate in the case of Thera is between the historians and the physicists. On the one side are dozens of radiocarbon dates that are all fairly consistent with each other, both from Tell el-Dab‘a and from the island of Santorini. On the other side is a tight, well-defined historical sequence that does not appear capable of stretching to accommodate the radiocarbon estimates (fig. 33).

Given the inherent uncertainty associated with radiocarbon dating it would seem unwise to rely on ^{14}C for determining the transitions between the various Early Bronze periods. Unfortunately, it has all too often been the only “scientific” or “objective” data available in a region that lacks early written records and, as a result, has had an inordinately large affect on the chronological debate of the Levant. In fact, while the absolute chronologies of the surrounding regions (Egypt and Mesopotamia in particular) have steadily been lowered over the last century, the chronology of the Israel/Jordan region has experienced the opposite trend. Whereas earlier scholars (Albright, Yadin, Lapp) proposed ending the EB III around 2100 or even 2000, more recent scholars (Dever, Mazar, Mellaart, Meyers) have pushed the date back to about 2300 or even earlier. This shift has not been based on the discovery of written sources, or even synchronisms with other regions, but on radiocarbon alone.

Absolute Dates for the EB III / EB IV Transition

So what absolute date should be attached to the EB III/IV transition? Early estimates often centered around 2000 (Albright 1961, 1974) or 2100 (Lapp 1975; Yadin 1975). Amiran recognized that "the beginning of the MB I period in Palestine cannot be much later than the Akkad dynasty. Consequently, in absolute terms, c. 2250-2200 B.C.

LB II	B.C.	EGYPT RELATIVE CHRONOLOGY	TELL EL - DAB 'A					GENERAL PHASES
			TOWN CENTRE (Middle Kingdom) 'Ez. Rushdy	NEW CENTRE MB-Population	EASTERN TOWN	NORTHEASTERN TOWN	PALACE DISTRICT 'Ez. HELMI	
			R / I	F / I	D / 2	A / V	H / I-VI	
	1410	Dyn.						
LB I	1440	XVIII AII H TIII TII ITI AI	Destruction of Tell el-Dab'a by Ahmose	HIATUS			Thera Pumice c	C / 2
	1470						Paintings d	C / 3
MB III	1500	AHMOSE	± 1530 BC				e / 1.1-2	D / 1.1-2
	1530		DENUDED		D / 2	D / 2		D / 2
MB II	1560	XV HYKSOS		a / 2	D / 3	D / 3	g-h	D / 3
	1590		DENUDED & PITS	b / 1	E / 1	E / 1		E / 1
MB I-II	1620	↑ KING- DOM OF AVARIS - NEHESI		b / 1	E / 2	E / 2		E / 2
	1650			b / 2	E / 3			E / 3
MB I	1680			b / 3	F			F
	1710	XIII	DENUDED & STORAGE PITS	EPIDEMIC c HIATUS	G / 1-3			G
EB IV	1740			d / 1	G / 4			G / 4
	1770			d / 2 $\frac{d/2a}{d/2b}$	H		UNOCCUPIED	H
EB IV	1800	XII So AIV AIII		b / 1				
	1830			b / 2				
EB IV	1860	XII SII SIII S I		c / 1-2 5 th year S III	HIATUS		Temple enlarged, Sesostris III yr 5	I K
	1890			d			± 1868 BC	L
EB IV	1920			e / 1-4				M
	1950			f	e / 1		UNOCCUPIED	N / 1
EB IV	1980	XI		? HERACLEO- POLITAN FOUNDATION	e / 2-3			N / 2-3
	2000							
	2050	X					EXPANSION OF THE SETTLEMENT	

Fig. 33. Sequence of phases at Tell el-Dab'a, adapted from Bietak and Höflmayer 2007: 15, fig. 2. Note especially the two datum lines (red) that anchor the intervening phases for the period between Sesostri III and Ahmose. The accession year used by Bietak for Sesostri III is 1873, compared to the lower date of 1836 used by Baines and Malek (2000) and Krauss (2006). If the lower dates are correct, the EB IV should end around 1880 rather than 1920.

seems nearer to the facts than the generally accepted date of c. 2150" (Amiran 1960: 224). In this case Amiran used a high Mesopotamian chronology; if her synchronism is applied using a low Mesopotamian chronology, the EB IV would begin around 2060 B.C. Likewise, Tufnell connected the EB IV with either late Akkad or Ur III, using the middle Mesopotamian chronology (1966: 205). If the low Mesopotamian chronology were to be used instead, her EB IV would instead begin around the middle of the 21st century B.C.

However, as radiocarbon dating became more common and was deemed more trustworthy, the chronology moved back in time. It is not uncommon now for the transition to be dated around 2300 (Dever 1992; Meyers 1997; Mazar 1990) or even higher (Mellaart 1980; Long 2003). These high dates are able to accommodate high radiocarbon dates yet also favor high chronologies in Mesopotamia and Egypt.⁵³

However, as demonstrated above, the trend in absolute chronology for both Mesopotamia and Egypt has been distinctly downward, and there remain serious issues with the reliability of radiocarbon dating. Although these issues have been widely acknowledged in Mesopotamian and Egyptian studies and thus the chronologies in those areas are being lowered, there seems to be a certain reluctance in the Levant to either acknowledge these trends or to apply them to Levantine chronology. The work of Bietak at Tell el-Dab'a has finally seemed to convince most archaeologists that lower dates are appropriate for the Middle Bronze Age in Palestine, but the logical step of lowering the preceding Early Bronze periods has yet to be taken. This may be due to an overreliance on radiocarbon dating and a reluctance to question the usefulness of the method, but regardless of the cause a downward shift is overdue.

⁵³ See especially Mellaart 1980, who followed the high Mesopotamian chronology.

Two other recent studies are worth noting at this point. From his work at Sidon on the Lebanon coast, Claude Doumet-Serhal has concluded that it is difficult to distinguish a unique EB IV period between the EB III and MB IIA.

The last quarter of the third millennium, that has in terms of terminology and chronology been so controversial, appears at this site as a *continuum* and an extension of earlier material, with influences from Syria maintained as an inherent development at the beginning of the MB IIA. Clearly the use of EB IV is valid for some regions and the reason that Stratum 6 has not been called EB IV but EB IIIB is that there is no distinct change (see also Doumet-Serhal 2006b, 13). At this stage a degree of flexibility must be admitted which takes into account substantial chronological overlaps, allowing the contemporaneity of EB III/EB IV and EB IV/MB IIA types within the same chronological horizon. (Doumet-Serhal 2009: 32)

It seems difficult to imagine that this overlap/transition at Sidon could have lasted for centuries.

Further south along the coast of Israel, Ram Gophna studied 30 settlement sites and 26 burial sites dated to the EB IV (his Intermediate Bronze Age). "In most cases the excavators note that only two or three architectural phases were uncovered. This suggests that the settlements existed for approximately three generations, that is, less than one hundred years" (Gophna 2009: 35). Gophna recognizes that it has been common to attribute about 300 years to the EB IV (e.g., Dever 1992), and his solution is to posit a century-long gap on either side of the EB IV in order to accommodate that time period (fig. 34).

But the creation of gaps or "dark ages" brings its own set of problems, and such periods have tended to evaporate upon closer study. It may in fact turn out that earlier scholars were not so far off in their estimates of a two-century EB IV. Albright (1974: 10) placed it at c. 2000-1800, while Yadin estimated 2100-1900 (1975: 269).

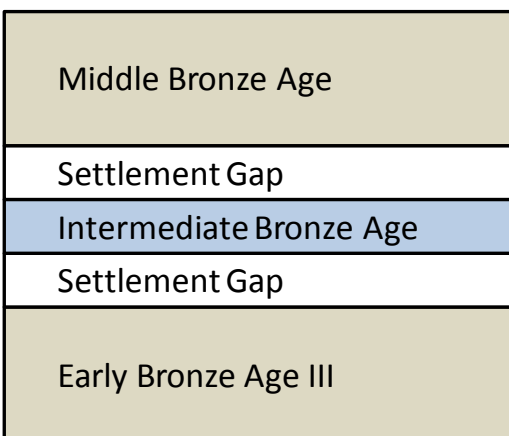

Fig. 34. Proposed gaps on either side of the EB IV along the coast of Israel (after Gophna 2009: 36, fig. 2).

In the Transjordanian area, particularly in the region surrounding Bab edh-Dhra', there are typically two to three phases at EB IV sites. At Iktanu and 'Arô'er there appear to be two, while at least three are evident at Iskander, Niaj, Um Hammad, and Bab edh-Dhra' (Richard 2003: 298). How long did each phase last? If each endured for about a generation the period would have lasted about a century to a century and a half. While Dever has suggested a 400-year span for the EB IV, Gophna argues for not more than 200-250 years (1992: 127). But even Gophna's lower estimate is based on starting the EB IV sometime during the Egyptian 6th Dyn sometime during the 23rd century and ending it about the time of the establishment of the Middle Kingdom; both start and end dates still have considerable uncertainty.

Summary: Feasible High and Low Estimates

In summary, recent trends are pushing the beginning of the Middle Bronze period down to around 1900 (Bietak 1996; Ben-Tor 2006); Redford even argues for pushing the end of the EB IV well into the 19th century (1992: 93, n. 122). It is not unreasonable,

then, to estimate the start of the EB IV somewhere within the 21st century B.C., as this would give at least a century to the period, and possibly more.

It may be suggested, then, that the transition between EB III and EB IV took place anywhere between a high date of 2350 and a low date of 2050. The preference would be toward the lower end of this spectrum, based on recent developments in the chronology of this region as well as those of Egypt and Mesopotamia, but contra radiocarbon dating.

CHAPTER 4

ABSOLUTE CHRONOLOGY AND ABRAHAM

In this section I will present a variety of options for the absolute dates that may be assigned to the patriarchs. Because the events relating to the Cities of the Plain fall within the life of Abraham, that period will be the specific focus of this chapter. I will first review the various pieces of data that are most often used in calculating an absolute date for Abraham, and then I will review a variety of suggestions that have been made for piecing it all together.

Biblical Evidence

Virtually all modern biblical chronologies are built off of the ground-breaking work of the Adventist scholar Edwin Thiele. For more than 2,000 years the numbers given in the OT for the reigns of the Hebrew kings had confounded scholars. They appeared inconsistent and contradictory, tempting many who worked with the OT to conclude that its numbers had been hopelessly corrupted. Using newly discovered information from Assyrian and Babylonian records and an ingenious application of the long-known phenomenon of differing calendars and methods of calculating reign lengths, Thiele was able to demonstrate that in fact the OT regnal lengths added up in a very plausible and consistent way. Thiele showed that the numbers were in fact correct, and could be used to reconstruct a sensible and consistent chronology of the Hebrew kings, one that fit extremely well with non-biblical data (Thiele 1983). A number of minor

corrections have been made to Thiele's original work, but by and large it has stood the test of time.⁵⁴ Of greatest interest to our work is that Thiele established that Solomon died in 931 B.C. This date then serves as the anchor point for all attempts to work backward in time.

Table 2 presents a list of OT passages that give what appears to be relatively straightforward evidence that could be used to reconstruct the absolute chronology between Solomon and Abraham.

Table 2. Selected OT chronological references

Text	MT	LXX
1 Kgs 11:42	Solomon reigned 40 years over Israel.	same
1 Kgs 6:1	Construction on the temple was begun in Solomon's 4 th year, 480 years after the Exodus from Egypt.	Construction began in the 440 th year after the Exodus.
Exod 12:40	The sojourn in Egypt was 430 years in length.	The sojourn in Egypt <i>and in Canaan</i> was 430 years.
Gen 47:9	Jacob (Israel) was 130 years old when he and his clan entered Egypt.	same
Gen 25:26	Isaac was 60 when Jacob was born	same
Gen 21:5	Abraham was 100 when Isaac was born.	same
Gen 15:13	Abraham's descendants will be enslaved in a land not their own for 400 years.	same
Judg 11:26	Jephthah refers to the Israelites as having dwelt in the land some 300 years already.	same

⁵⁴ Most corrections that have been suggested have to do with the length of coregencies or refinements of a year or two for a particular event. For example, McFall (1992: 35-38) suggests that Thiele missed four coregencies; Young has been able to refine the dates for the fall of Samaria and of Jerusalem (Young 2004a: 21-38 and Young 2004b: 57-95). There have been more thorough-going attempts at revising Thiele's work, but none has found wide acceptance, nor seems likely to. Galil, for example, has attempted wide-ranging revisions, yet his system requires numerous emendations of the Hebrew text that are both unnecessary and unhelpful (Galil 1996).

Several NT passages also refer to the length of the patriarchal period and/or sojourn.

Table 3. Selected NT chronological references

Text	Description
Acts 7:6	Stephen refers to the OT prophecy that Abraham's descendants would be enslaved in a foreign land for 400 years, an apparent quote of Gen 15:13.
Acts 13:19	Paul refers to a period of 450 years which ended with the conquest of Canaan.
Gal 3:17	Paul states that the Law came 430 years after the covenant.

Evidence within the OT that is somewhat less direct includes the following: (1) the various references to the length of the cycles within the book of Judges;⁵⁵ (2) genealogies of the judges period, such as Ruth 4:18-22, which could allow a count of generations; and (3) genealogies of various lengths that pertain to the time of the sojourn in Egypt.

A straightforward reading of the MT gives a birth date for Abraham at about 2165 (e.g., Ray 1986). If the LXX is followed, the birth date of Abraham is reduced by some two centuries to about 1950 (e.g., Beitzel 1985). The NT passages cited above can generally be made to fit whichever of these two textual traditions is preferred.

⁵⁵ Of particular interest for the chronology of the judges period is the detailed study of Steinmann 2005: 491-500. Steinmann makes a convincing case that the numbers given in the OT for the various judges cycles are part of a coherent system and that individual judges can be accurately dated within that period. He reckons the length of time from the start of the conquest (1406) to the coronation of Saul (1048) at 358 years.

Non-Biblical Evidence

Numerous kinds of non-biblical evidence have been employed in various ways by those attempting to calculate an absolute date for the patriarchs. Although they have the advantage of being extra-biblical and thus are not subject to the charge of being theologically influenced, they have their own weaknesses. Nevertheless, each of the items below must be taken into consideration by anyone wishing to assign a calendar date to the patriarchs.

Merneptah Stele

There are a number of indirect lines of evidence regarding the periods that precede the Hebrew kings. Perhaps the best known is the Merneptah stele. Dated to about 1209 B.C., it records an earlier victory over a people-group known as "Israel" in the land of Canaan (fig. 35).⁵⁶ The text of the relevant portion is as follows:

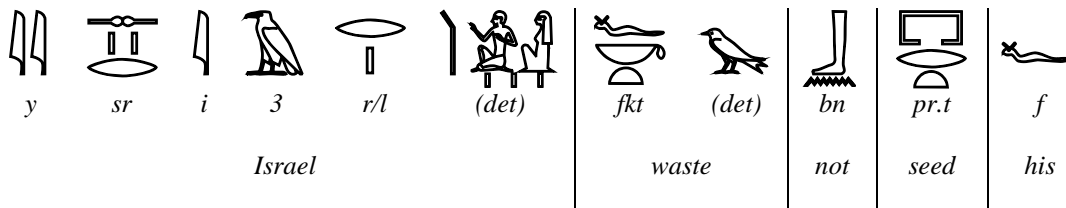

Fig. 35. Text of the reference to Israel in the Merneptah Stele.

⁵⁶ Kitchen dates the stele to the 5th year of Merneptah's 10-year reign and reckons it at "c. 1209/08 BC – NOT 1207, as is often misquoted"; see Kitchen 2003: xxv.

Although there is some disagreement over what it is that Merneptah claims to have done to Israel,⁵⁷ it is widely acknowledged that this inscription "does indicate that Israel was a significant socioethnic entity that needed to be reckoned with" at the end of the 13th century (Hasel 1994: 54-6, n. 12). It has generally been reckoned as providing a *terminus ante quem* for the existence of an "Israel" in Palestine.

"Shasu of Yahweh"

The term "Shasu of Yahweh" appears in Egyptian inscriptions of the 18th and 19th Dynasties. Two such inscriptions have been found so far.⁵⁸ The later specimen was found at Amara West in Upper Nubia (Fairman 1939). This site was established by Seti I (c. 1290-1279), and a temple was built there by his successor, Ramesses II (c. 1279-1213). It may be inferred that this inscription dates to about 1240 B.C.

The Amara West inscription was copied from an earlier exemplar at the Temple of Amun in Soleb, Sudan (fig. 36, 37). This temple was built by Amenhotep III (c. 1390-1353) and thus dates to around 1375 B.C. The inscriptions take the following form as shown in figs. 36 and 37.

Astour (1979: 18) has observed that the hieroglyphic rendering of this item "corresponds very precisely to the Hebrew tetragrammaton, YHWH, or Yahweh, and

⁵⁷ Hasel acknowledges the traditional interpretation that Merneptah's statement "his seed is not" is a hyperbolic statement referring to Israel's offspring. He prefers, however, to take the more literal sense of "seed," suggesting that "Israel's food supply/subsistence is no longer in existence" (1994: 53). Kitchen (2003: 15) provides the generic translation "Israel is laid waste, having no seed."

⁵⁸ Recent references to these inscriptions include Hoffmeier (2005: 240) and Rainey (2007: 55). The preliminary report on the Amarah inscription was made by Fairman (1939).

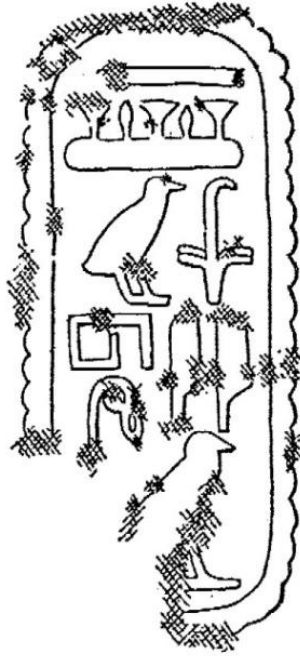

Fig. c. L'écusson IV N 4 α 2.

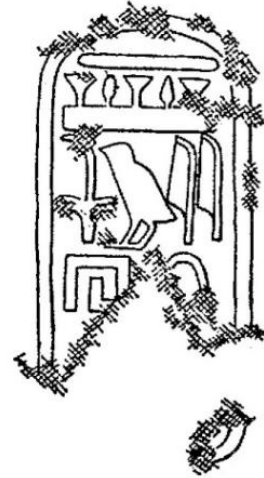

Fig. e. L'écusson du bloc II 69 de Soleb.

Fig. 36. Two name rings of the “Shasu of Yahweh” from Soleb (adapted from Leclant 1965: 215, figs. c and e).

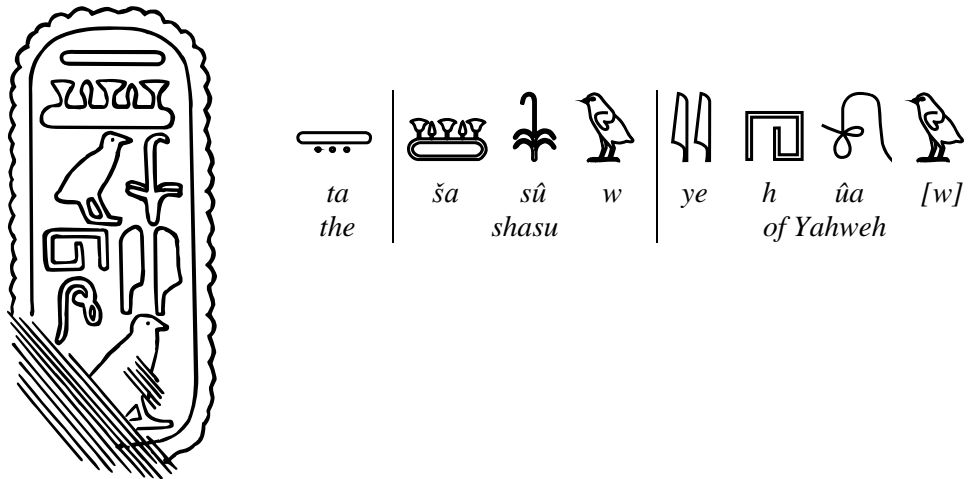



Fig. 37. Text of the “Shasu of Yahweh” inscription.

antedates the hitherto oldest occurrence of that divine name—on the Moabite stone—by over five hundred years.”⁵⁹

Shasu was a term used by the Egyptians to refer to Bedouin-type foreigners in Canaan. So who were the *shasu* of Yahweh? Redford states that "for half a century it has been generally admitted that we have here the tetragrammaton, the name of the Israelite god, 'Yahweh'; and if this be the case, as it undoubtedly is, the passage constitutes a most precious indication of the whereabouts during the late fifteenth century B.C. of an enclave revering this god."⁶⁰ Redford goes so far as to call this group "nascent Israel," no small admission from a scholar who in the same chapter chides Albright for his naïve belief in a historical Moses.⁶¹

There is not sufficient context for the “shasu of Yahweh” inscriptions to say much about them. There is no indication of size, names of leaders, origin, or exact geographical location. However, these inscriptions do provide extra-biblical evidence for the existence of a group at an early time that could be the biblical Israel. At the very least, the position of those who claim a complete lack of evidence for pre-monarchic Israel is called into question.

⁵⁹ There are actually two extant inscriptions of the Shasu of Yahweh at Soleb, although both are damaged. Drawings are provided in Leclant (1965: 215, figs. c and e) and in Schiff-Giorgini (1998: 207, 221). A photograph of the better preserved ring may be found in Leclant (1965: 214, fig. 15).

⁶⁰ Redford (1992: 272 -3). For an earlier and more cautious analysis, see Horn 1953: 201— "Whether one of the Edomite tribal names bearing the name Yahweh  (t3 š3sw yhw) implies that Edomites were followers of the god Yahweh or whether the name of the tribe has only a curious coincidence with the name of the Israelite god is still undecided." Horn's rendering of *shasu* as "Edomite" appears to have somewhat obscured his understanding of the inscription.

⁶¹ Redford (1992: 279). Helpful analysis and useful bibliography on the “Shasu of Yahweh” are also provided by Hoffmeier (2005: 242-3).

Berlin Statue Pedestal Relief 21687

Manfred Görg (2001) has recently drawn renewed attention to an inscription in the Egyptian Museum Berlin. The inscription may date from as early as the reign of Amenhotep II (c. 1427-1400) and contains the name rings of three Egyptian enemies.

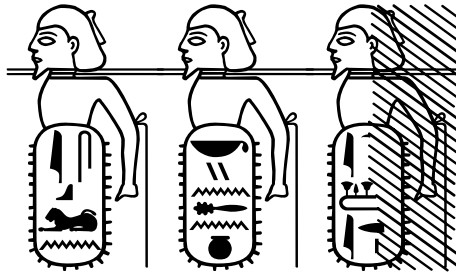

Fig. 38. Text of the Israel Inscription in the Berlin Egyptian Museum.

The first two, "Ashkelon" and "Canaan," are complete name rings and their identifications are clear (fig. 39). The third name ring is partially damaged, requiring the restoration of some letters, although it would appear that at least some portion of each letter is present.



Nearly three decades ago, Giveon (1981) read the name ring tentatively as

 , יִשְׂרָאֵל . However, Görg (2001) has pointed out that Giveon's



Fig. 39. Text and translation of the first two name rings in the Israel Inscription in the Berlin Egyptian Museum.

reconstruction is faulty on two grounds. First, the reconstruction of the second reed sign is faulty. Rather than the top of a second reed, a slightly curved incision is clearly preserved which could only belong to the beak of a bird. Thus Görg reconstructs the common vulture sign, , 3.

Secondly, Görg suggests that the insertion of the reed mat/stool sign , š3, is not feasible because the lotus flower and pool sign , š3, requires the full width of the name ring, leaving no room for the additional sign hypothesized by Giveon. Based on the photo published by Görg, this does indeed appear to be the case. The letters reconstructed by Görg are as follows (fig. 40):

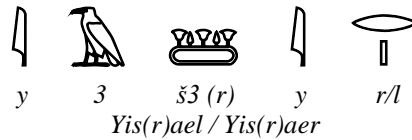

Fig. 40. Text and translation of the third name ring in the Israel Inscription in the Berlin Egyptian Museum.

Görg further notes that in Middle Egyptian it is not uncommon for the š3 sign to represent šr or šl in practice, and he gives several examples of this.⁶² He concludes that this name is at a minimum "compatible" with the name Israel.

⁶² For example, *b3-ḏ3-n3* (=bd(r/l)n), for Busruna, *J-k3-ti* (=Jk(r/l)t) for Ugarit, and *Q-n-tj-k3-m-r* (=Kntk(r/l)mr/l) for Ginti-Kirmil (Görg 2001: 25).

The inscription has been viewed in person by several other scholars who have confirmed Görg's reading.⁶³ If true, this reading may prove to be a challenging piece of data for those who do not accept the existence of Israel prior to the beginning of the Iron Age. Up to now the Merneptah stele has provided an early Iron Age *terminus ante quem* for "Israel." This inscription seems to provide an even earlier *terminus ante quem* for the existence of a socio-ethnic group named "Israel" in Palestine during the first half of the Late Bronze Age, perhaps even signaling the demise of the "late" Exodus scheme.

Excavation of Various Sites

In theory, the excavation of sites should help answer some of the questions regarding the historicity or age of some OT events. One would expect to be able to find remains, for example, of a given city in a given period if it is mentioned in the Bible. In practice, however, this has proven to be a contentious issue. Proper site identification can be tricky, as with the city of Ai. Joseph Callaway identified the ruin of et Tell as ancient Ai. His excavations there revealed a gap between the Middle Bronze and the Iron Age. More recently, Bryant Wood has suggested Khirbet el-Maqatir as a better candidate for Ai, based on geographical considerations, the age of the remains (an LB I fortress), and the layout of the town site (gate on the north side of the town, overall smaller than Gibeon), which appears to match the biblical description (Wood 2000: 123-30). Thus Callaway's claim (1985: 68) that he "worked nine seasons between 1964 and 1976 and

⁶³ These include Peter van der Veen, John Bimson, Stephan Wimmer, and Christoffer Theis. High-resolution photographs taken by van der Veen and made available to the author confirm the existence of the beak of the vulture sign; van der Veen, personal communication, 2008. See also van der Veen, Theis, and Görg 2010.

spent nearly \$200,000, only to eliminate the historical underpinning of the Ai account in the Bible” may well be a false conclusion based on the misidentification of the site.

For sites that are safely identified, there is often disagreement over the finds. Jericho is a classic example of a site that is agreed by all to be correctly identified, has been excavated several times, but has produced results that are ambiguous. Garstang claimed to have found Joshua's city at Jericho during his excavations there in the 1930s. Kenyon revisited the site in the 1950s and concluded that the site was mostly abandoned during the LB age. More recently, Wood has reviewed Kenyon's pottery from Jericho and believes that good evidence of LB occupation was left out of the final reports (Wood 1990: 51-3). Also, some sites have never been excavated or cannot be excavated because they are under a modern city.

In general, those who argue for a late Exodus point to various sites that appear in the biblical text but do not appear in the archaeological record in the earlier periods (including foreign cities such as the store cities of Exod 1:11). Those arguing for an early Exodus counter with alternate site locations or a different interpretation of the evidence. Although used as evidence by both sides of the chronological debate, so far the archaeological evidence has not proven decisive.

Climate Change and Early Geography

Paleoclimate is one of the more obscure data sets in this debate, yet for some scholars the evidence it presents is compelling. In 1982, James Sauer stated that "in my opinion, it is only at the end of the Late Bronze Age and in the Iron Age, c. 1300 B.C., that the archeological evidence and the biblical sources can begin to be correlated" (Sauer 1982: 208). Sauer considered the earlier periods to be mythical in nature, having no basis

in history and probably no historical recollection whatsoever. However, based on more recent evidence of climatic variations in the EB, Sauer has reversed his earlier opinion. He now considers it a "likely conclusion that the Early Bronze sites of Bab edh-Dhra', Numeira, and so forth probably were some of the 'Cities of the Plain'. . . . I agree with David Noel Freedman (1978) about the third-millennium BCE date for the patriarchs" (Sauer 1994: 390). "Since the memories of climatic change and of early geography seem so accurate, it could even be suggested that some of these traditions may not have been written down for the first time in the tenth century BCE but were in fact written down much earlier" (Sauer 1994: 391).

Using a combination of geologic evidence (e.g., dark layer soils in areas that are today desert, evidence of now dry wadi beds, etc.), dendrochronology, ice cores, and pollen data from cores in Lake Hula and the Mediterranean, Sauer reconstructs the following: a wet phase in the Chalcolithic period, with a drier ending, a wetter EB I, a somewhat drier but still moist EB II-III, and a more arid EB IV.⁶⁴ As Sauer sees it, the wetter Chalcolithic phase is reflected in the Genesis recollection of a Mesopotamian flood in Gen 6-9 while the drier EB IV is to be seen in the extended famine during the days of Joseph in Gen 41-47. "Most of the Albright school had been opposed to using climate change in this way, but in fact it is more supportive of the early biblical traditions than any other existing data" (Sauer 1994: 373).

⁶⁴ This conclusion is in basic agreement with the reconstruction of Neev and Emery (1995: 62), which is based on the fluctuating levels of the Dead Sea waters.

Cultural/Sociological Indicators

A number of various cultural and sociological indicators have been suggested over the years that potentially relate to the patriarchs. An early suggestion was made by Albright. He noted the expansion of EB IV/MB I settlements in the Negev, many of them located along caravan routes. He concluded that these small sites must have been established by donkey caravaneers and that such a nomadic, transient lifestyle perfectly fit the biblical description of the life of Abraham (Albright 1961). Albright's thesis has since been largely discredited, in part simply for lack of corroborating evidence.

Kenneth Kitchen has collected numerous cultural/sociological items that could indicate a second millennium B.C. setting for the patriarchs. His comparison of slave prices in the Old Testament, which rise over time, seems to match the rise in ANE slave prices during the second millennium (Kitchen 1995, 2003a). He has also studied treaty/oath formulae, again concluding that the development of such formulae in the OT matches, or at least does not contradict, the development of the same in the ANE. The components of treaties and oaths, as well as the typical amount of space granted to each component and the order of the components, are favorably compared and contrasted.⁶⁵ Another indicator is the geo-political environment. Only during the second millennium and not during the first, notes Kitchen, can one find a geo-political situation similar to that found in the biblical patriarchal period. The weakness of Egypt and the lack of a real power in Mesopotamia appear to be well suited, for example, to the battle of four kings against five in Gen 14.

⁶⁵ See also Hoffmeier 2008: 60-62 for an affirmation of Kitchen's general scheme.

Donald Wiseman places the patriarchal age in the MB I, based on such things as the occupation of city-states (Bethel, Shechem, Hebron, the Dead Sea region), personal names (Abram, Nahor, Terah, Serug, Laban, Benjamin, etc.), and social customs (marriage contracts, betrothal and bride-gifts, the special position of the first-born, etc.). Additionally, "from a study of the Mari texts, it is evident that an incident like that related in Genesis 14 . . . could likely have taken place only in this period, which, according to the Mari letters, was one in which such coalitions were formed" (Wiseman and Yamauchi 1979: 18). He also cites evidence of camel bones, representations on seals, plaques, and figurines, and Sumerian and Babylonian textual references from the MB I and earlier to show that the patriarchal references to camels are not an anachronism.⁶⁶

Walter Kaiser has gathered information on the inheritance standards used in various centuries. He states that,

indeed, the patriarchal narratives contain a distinctive flavor, pattern of living, and several unique socio-legal institutions that are not found in the social mores and norms of later ages. For example, in Genesis 49, Jacob blessed his twelve sons, giving to each of them an *equal* share of the inheritance. Later, at Sinai, this would change with the Mosaic law specifying that a *double* share of the inheritance go to the first born son (Deut 21:15-17). Wellhausen had seen this disparity, but explained it by saying that different writers had composed conflicting accounts of the Pentateuch during Israel's postexilic times. However, the extrabiblical texts from the ancient Near East confirmed that the situation reflected in Jacob's distribution of an *equal* inheritance for all his sons was precisely what was found in the Laws of Lipit-Ishtar (twentieth century B.C). Some 200 years later in Hammurabi's Code, (eighteenth century B.C.), the situation had changed already so that the sons of a man's first wife got first choice over the sons of his second wife. When we go further, from the eighteenth to the fifteenth century B.C., the tablets from Mari and Nuzi demand that the natural first born son was to receive a *double* share over that of the adopted son. Finally, the first millennium Neo-Babylonian laws required the same distribution, with the sons of the first wife getting a double portion and the secondary sons only receiving a single share. (Kaiser 2001: 86)

⁶⁶ Incidentally, a large camel bone was also recovered from the Stratum IV (EB IB) excavations at Bab edh-Dhra' (Rast and Schaub 2003a: 120). It was located on an ash streak above brick debris.

Dever (1977: 128) lists numerous factors that are frequently mentioned as types of external (mainly indirect) evidence that might date the patriarchs. These include letters from Mari, Egyptian execration texts, the Sinuhe story, the Amarna letters, references to the Hapiru, Babylonian legal documents, the Nuzi texts, northwest Semitic personal names, and archaeological data from places mentioned in the patriarchal narratives. Dever concludes that these various indicators place the patriarchs immediately before Joshua, if in fact the patriarchs are not just a theological construct (1977: 145-7).

Fleming (2004) and Hess (2004) have recently compared biblical texts with documents from Mari (Middle Bronze Age) and Emar. Fleming finds significant parallels between the patriarchal descriptions in Genesis and the newly published Mari data. He specifically mentions four parallels: (1) the tribe named Benjamin, in relation to the Syrian tribal coalition called the Binu Yamina; (2) an ancestral homeland associated with the particular city of Harran, in far-northern Syria, a gathering point for the Binu Yamina tribes; (3) the biblical use of the adjective "Hebrew" for identifying Joseph and his family in Egypt, in relation to the Binu Yamina *'ibrum*, the part of the tribal population that remains full-time with the flocks; (4) the division of the pasture between Abram and Lot by the right and left hands in Gen. 13:9, in light of the broad definition of Syrian tribal peoples into two coalitions, as "sons of the right hand" (Binu Yamina) and "sons of the left hand" (Binu Sim'al) (Fleming 2004: 194-5).

Hess compares the multi-month calendar of the Late Bronze Age tablet Emar 446 with Lev 23, concluding that while "multi-month cultic calendars remain a rare occurrence, little separates the Emar and Leviticus calendars from one another. They remain similar in many features of form, structure, and content, despite the distinct

religious worldviews that each embodies" (Hess 2004: 253). Although neither Fleming nor Hess is prepared to date either the patriarchal narratives or their date of composition by such parallels, they do point toward a specific *background* for these events that is clearly earlier than the first millennium B.C.

Proposed Chronological Schemes

Iron Age

On the lowest end of the chronological scale are those who assign the patriarchs to the Iron Age period. It is typical of those who hold this view to speak of the origin of the patriarchal *tradition* in this period, as they tend to reject the historical reality of the patriarchs themselves.

One of the severest critics of the patriarchal narratives is Thomas Thompson. In his 1974 treatment of the patriarchal narratives, Thompson sets out to show that "in this quest for the historical Abraham, we are not dealing with a legitimate historical reconstruction which merely lacks verification; we are rather dealing with a search that is essentially misdirected. Not only has the historicity of Abraham not been proven, but it does not seem to be implied in the biblical narratives themselves" (Thompson 1974: 9). Upon reviewing the chronological evidence for this period in the various textual traditions of the OT, Thompson prefers to follow the earlier work of M. Johnson to the effect that "the Masoretic system is a theological construction based on a chronological scheme of a Great Year of 4000 years, which is fulfilled at the rededication of the temple by the Maccabees in the year 4000 A.M." (Thompson 1974: 14). This leads naturally to the conclusion that "we cannot use any of the extant chronological systems to arrive at an absolute date for the patriarchal period" (Thompson 1974: 15). Thus, any attempt at

"historicizing Genesis is a serious error in biblical interpretation, and, to the extent that it depends upon the evidence we have from Near Eastern nomenclature, totally unfounded" (Thompson 1974: 21).

A similar position has been advocated more recently by Redford. After pointing out some supposed mis-references in the OT to Egyptian kings of the 25th Dynasty, Redford (1992: 258) states that

we cannot help but conclude that the Biblical writers of the seventh to sixth centuries B.C. lacked precise knowledge of Egypt as recent as a few generations before their own time. Such ignorance is puzzling if one has felt inclined to be impressed by the traditional claims of inerrancy made by conservative Christianity on behalf of the Bible. And indeed the Pentateuch and the historical books boldly present a precise chronology that would carry the Biblical narrative through the very period when the ignorance and discrepancy prove most embarrassing.⁶⁷

Why, then, do others find the patriarchal narratives historically believable? For Redford the only answer is that the strength "of a confessional commitment to bolster a pre-judgment will not allow most conservative Jewish or Christian exegetes to discard the whole chronological arrangement, and recent work has proven Muslim scholars similarly in thrall" (Redford 1992: 259).

In connection with Albright's attempt to place Abraham in the late 14th century, Redford can only conclude that "Crypto-orthodox tendencies drive some scholars to ludicrous ends" (Redford 1992: 260, n. 11). An apt comparison, in Redford's view, would be the stories of King Arthur. "Who were consuls of Rome when Arthur drew the sword from the stone? Where was Merlin born? Where is Avalon to be located?"

⁶⁷ What is most puzzling about Redford's subsequent reconstruction of the reign lengths of the Hebrew kings is that he completely ignores the progress made by Thiele and others in the last 50 years. His desire to construct a round-numbered 430 years to match the 430-year figure given in Exod 12:40 for the sojourn, thus proving the biblical figures to be schematic and unhistorical, suggests itself as a possible motive.

(Redford 1992: 261). Such statements amply illustrate the negative view taken by some regarding the historicity of the patriarchal narrative. In the view of such a position, the present investigation would surely be futile. As Dever (1977: 120) has stated, if such a view is correct, "archaeology can reconstruct no 'historical' background for the contents of the patriarchal traditions, since by definition there is none." For Dever then, "the whole 'Exodus-Conquest' cycle of stories must now be set aside as largely mythical, and the patriarchal period itself is a theological construct originating in the Late Bronze and Early Iron Age" (Dever 2001: 121; 1977: 147).⁶⁸

1425 B.C.

Among those who look for a historical setting for the patriarchs, the lowest suggested dates have been attributed to the Late Bronze Age. C. H. Gordon relies on general genealogical information and analogies with the Amarna Age to place the birth of Abraham in the late 15th century B.C. He views the statement in Gen 47:11, that Joseph gave Jacob a possession "in the land of Rameses," as a clear indication that Jacob entered Egypt during the Ramesside Age, which began in the late 14th century. "If Jacob was aged late in the fourteenth century, his grandfather Abraham would have been born in the latter part of the fifteenth century and hence flourished during the Amarna Age" (Gordon 1953: 103).

In addition to the "land of Rameses" statement, Gordon points to the numerous parallels between the Amarna Age archives from Nuzi in Mesopotamia and the

⁶⁸ The other two possibilities Dever suggests are that the patriarchal traditions belong to the phase of Hebrew history immediately prior to the settlement as it appears in Joshua (although this conflicts with Dever's view that Joshua was also a mythical character) or that the traditions reflect individual episodes taken from the contemporary culture of the Exile by the J source, a view espoused by Thompson and Van Seters, and one that Dever rejects (Dever 1977: 145-6).

patriarchal accounts. These include references to adoption, the taking of a second wife in cases where the first was barren, and the transfer of the family gods to the firstborn.

One striking result of placing the patriarchs in the 15th-14th centuries is that the sojourn in Egypt becomes very short. In fact, it "could be spanned by a single lifetime" (Gordon 1953: 103). Gordon finds biblical support for such a short sojourn in some of the more brief genealogies of the OT, as well as in the fact that two midwives could handle the obstetrical needs of all the Hebrews (Exod 1:15-21). Regarding the numbers given in the biblical account that conflict with such a view, Gordon is content to "lean on the genealogies and not on the reckoning in terms of years" (Gordon 1953: 105). Arab nomads down to the present day, he notes, memorize the names of ancestors back 10 or 15 generations, yet cannot tell their own age. This illustrates the ability of tribal groups to accurately retain genealogical information apart from a remembrance of numerical years. The biblical numbers "reflect schematic numbers taken over from the epic tradition" (Gordon 1953: 104, n. 6).

Although Gordon does not cite the specific genealogy on which he bases his view, he appears to refer to Exod 6:16-20, which gives only four generations from Levi to Moses. Reliance on such passages poses a problem for Gordon. Even granting that the genealogies are, in general, to be preferred over "schematic numbers," Gordon must still be selective in his choice of genealogies. For example, the genealogy from Ephraim, Levi's nephew, to Joshua seems to include eighteen generations, compared to the four given in Exodus. See Table 4.

Harris (1975: 675) has noted that many OT genealogies are incomplete, with only the more famous men mentioned. Kitchen refers to these short genealogies as "fourfold

identity tags." He notes their common occurrence in the OT along with fuller genealogies, and concludes that "this fourfold system of 'tagging' a person to tribe, clan, and family group should not be abused (as some have done) to set the patriarchs artificially in the fifteenth century because of supposed links with Nuzi customs" (Kitchen 2003: 357).

Table 4. Comparison of selected Sojourn genealogies

Exodus 6:16-20	1 Chronicles 7:20-27
Levi	Ephraim
Kohath	Shuthelah
Amram	Bered
Moses	Tahath
	Eleadah
	Tahath
	Zabad
	Shuthelah
	Beriah
	Rephah
	Resheph
	Telah
	Tahan
	Ladan
	Ammihud
	Elishama
	Non
	Joshua

1675—1900 B.C.

Albright addressed the patriarchal period on numerous occasions, and his views varied over time. Prior to 1926, Albright argued for dating the events of Gen 14 (the battle of the four kings against five) at about 1675 (Albright 1926). However, his 1924 expedition to the Dead Sea region revealed the existence of Bab edh-Dhra'. Two

observations then led Albright to adjust his dates. One was the fact that five streams capable of supporting towns flowed into the Dead Sea in this region.⁶⁹ Albright had observed further north in the Jordan valley that every such stream that also had a small plain that could be irrigated supported an Early Bronze town, and he deduced that this must have been the case in the south as well. The other factor was the discovery of the cemetery at Bab edh-Dhra'. Based on the surface finds from this area and the "fortress" discovered there, Albright concluded that occupation in this region ended with the Early Bronze Age. "Bab ed-Drâ' was certainly abandoned before the foundation of Jericho IV, the Middle Bronze town, that is, roughly before the eighteenth century B.C." (1926: 61).⁷⁰ Although Albright did not believe he had found any Early Bronze cities and thus concluded that they were buried under the waters of the Dead Sea, he did believe "the mere fact that the material remains at Bab ed-Drâ' stop in the same general age as the end of Sodom and Gomorrah, according to any system of biblical chronology, cannot but be very striking" (1926: 62). Given the connection made between biblical text and tell, "the date we have fixed for the catastrophe of Sodom and Gomorrah, about the early part of the eighteenth century B.C., seems to be exceedingly probable" (1926: 66).⁷¹

⁶⁹ These five streams were the Seil el-Buqsâseh, Seil ed-Drâ', Seil 'Esâl, Seil en-Numeirah, Seil el-Qurâhî. Seil el-Feifeh is also mentioned, although Albright considered it "less important than the rest" (Albright 1926: 56).

⁷⁰ It may be interesting to note Albright's rationale for the 1800 B.C. date. He follows Macalister's chronology for Gezer, which is "based upon the fact that scarabs of the Egyptian Middle Empire (2000-1600 B.C.) are found at Gezer both with First and Second Semitic pottery, so that the division between these periods would fall roughly about 1800 B.C. This *terminus ad quem* is quite in accord with our conclusions from other premises" (Albright 1926: 60, n. 165).

⁷¹ It should be noted that chronology of Palestine was still very rough at this stage. The very existence of an EB IV period was still decades away from being recognized. When Albright published the first volume of his Tell Beit Mirsim pottery in 1932, his table of chronological periods jumped from an EB III that covered the "last third of the third millennium" to an MB I that was contemporaneous with the Egyptian 12th and 13th Dynasties (commonly known today as the MB IIa), followed by an MB II that

In 1961 Albright published an article on the new evidence in the Negev that was coming to light as a result of Nelson Glueck's systematic surface surveys. It was apparent that there was much pottery of the EB IV (now Albright's MB I), an indication of extensive agricultural settlements.⁷² Albright used several lines of evidence to suggest that this settlement pattern was related to a thriving donkey caravan trade that connected Canaan and Egypt. Albright dated the EB IV/MB I in Palestine to the period between 2000 B.C. and 1800 B.C., roughly equivalent to the Egyptian 12th Dynasty. He also assigned Abraham to this period, without attempting to specify an actual date. The connections he saw included the following: (1) many of the towns associated with the patriarchal tradition were occupied during the EB IV/MB I, including Shechem, Bethel, and Gerar; (2) Ur was a thriving trade city during this period; (3) Abraham's own activity as a caravaneer may be suggested by Gen 20:1, which Albright understood as saying that Abraham's family stayed in Gerar while he himself was down in Sinai leading caravans; (4) the well-known references to the *hapiru* of this period refer to donkey drivers or caravaneers and are to be equated with Abraham the "Hebrew" both linguistically and socially (Albright 1961).

By 1974, Albright felt that he was able to narrow the possible range of dates for Abraham. Although no excavations had yet been undertaken at Bab edh-Dhra', Albright was well aware of the pottery from the region, which indicated that occupation in the area

covered the Hyksos period, followed by the Late Bronze Age (Albright 1932a: xxi). Albright picked up what would now be considered EB IV pottery during his 1924 expedition to Bab edh-Dhra' and must be credited for placing it "relatively late in this [EB] period" (1924: 66).

⁷² Mazar (1990: 154) summarizes more recent surveys and excavations by Y. Aharoni, M. Kochavi, W.G. Dever, and R. Cohen that have largely substantiated Glueck's earlier findings and conclusions regarding EB IV Negev settlements.

ended abruptly "not later than 1800 B.C. at the outside" (1974: 137). He was also aware of the existence of exactly five oases in the region, which could have supported not more than five cities. Based on this evidence, and the presumed connection between the biblical cities of the plain, Abraham, and the occupation in this region, Albright concluded that "it does suggest very strongly that the date of Abraham cannot be placed earlier than the nineteenth century B.C." (1974: 137). This conclusion fitted nicely with Albright's previous view that Abraham belonged to the EB IV/MB I, serving only to narrow it down to the second half of that period, roughly 1900-1800 B.C. No effort was made by Albright to incorporate the chronological data in the OT with this date. It was based solely on the archaeological data from the southern end of the Dead Sea, Albright's dating scheme for the EB IV/MB I, and the connection he drew between those items. If Abraham's arrival in Palestine was sometime during the 19th century, and Abraham was 75 years old when he arrived, his birth would be calculated sometime between 1975 and about 1900 B.C.

1950 B.C.

Beitzel calculates the birth of Abraham sometime around 1950. He accepts an early date for the Exodus, around 1445, and follows the LXX and Samaritan Pentateuch in assigning the 430 years of Exod 12:40 to cover both the time spent by the Patriarchs in Canaan and the time spent by the Israelites in Egypt (Beitzel 1985: 85). This places the birth of Abraham around 1950.

This position is also held by Hoerth. Among other favorable considerations, Hoerth likes that this "puts Abraham in Mesopotamia's turbulent Isin-Larsa period, puts Joseph into Egypt during the Hyksos period, and places the exodus early enough to allow

later chronological references in the Bible to stand as they are" (Hoerth 1998: 58-9). He finds further support in Acts 13:19, "in which 450 years are said to extend from the patriarchal period through the conquest of the Promised Land" (Hoerth 1998: 58, n. 1). However, this understanding of Acts 13:19 is not universally held, and even stands in contrast to Acts 7:6, which refers to a 400-year enslavement "in a foreign land." Hoerth acknowledges the difficulty, but concludes that this second reference (a quote from Gen 15:13) must be applied not only to the sojourn in Egypt but also to the patriarchal period itself.

2000 B.C.

Kitchen and Mitchell (1980: 269) accept the 430 years of Exod 12:40 as referring to the Egyptian sojourn only, but they opt for the later date for the Exodus, placing it around 1280 or so. This places the entry of Jacob and his family into Egypt at roughly 1700 B.C., during the Hyksos period. This, then, means that Abraham's birth would fall at about 2000 B.C.

Kitchen (2003) reaffirms and expands on this position in his more recent work. His collection of external evidence includes some 17 items specific to the early second millennium or earlier, such as the East Delta residences of pharaohs, types of treaties, prices of slaves, the occurrence and frequency of particular proper names, characteristics of long-distance travel, social customs, and the use of a number of Egyptian terms that later went out of style (2003: 352-3). Combined with the internal evidence of the OT, Kitchen concludes that the patriarchs date "to the overall period circa 1900-1600 (2000-1500 at the outermost limits)" (2003: 358). Once again, the assumptions include an

exodus date around 1260/1250 and a 400-year sojourn, which would result in a birth date for Abraham at 1990 B.C.⁷³

Incidentally, virtually the same date was suggested by Smith more than 100 years earlier, who in turn followed the scheme set forth by Ussher. According to this view, the foundation of the temple in Solomon's fourth year happened in 1012, with the result that the exodus occurred in 1491. The 430-year sojourn was taken as covering both the sojourn in Egypt as well as the patriarchal age in Canaan, following the LXX. Thus Abraham left Haran in 1921 at age 75 and would have been born in 1996 B.C. (Smith 1884: 117). The chronology of the Hebrew monarchy was poorly understood at that time, but it is interesting to note the general similarity of Ussher's numbers with those of some modern scholars.

2165 B.C.

Perhaps the most common date espoused for the start of the patriarchal period among conservative scholars is 2165/2166 B.C. This view has been ably presented by Merrill (1980: 241ff.). The position is based on acceptance of Thiele's dates for the reign of Solomon and on acceptance of the Masoretic text over the LXX in the relevant passages.⁷⁴ Based on 1 Kings 6:1, Merrill concluded that the exodus took place in 1446, the so-called "early date" for this event. Furthermore, based on the Masoretic text of Exod 12:40, the sojourn in Egypt was 430 years in length, which places Jacob's arrival in

⁷³ For a critique of Kitchen's late date for the exodus, see Wood 2005: 475-89. Wood suggests that all three of Kitchen's main arguments for a late date are weak, and that both the archaeological data and the internal biblical data better fit a 15th-century exodus date.

⁷⁴ For a recent reappraisal and basic confirmation of Thiele's work, see Young 2005: 225-48. Young finds only minor revisions necessary in Thiele's work, and confirms the date of 971 for the beginning of Solomon's reign.

Egypt in 1876 B.C. Calculating back from that date, the birth of Abraham occurred in 2166 B.C. Furthermore, Merrill deduces that the destruction of Sodom and Gomorrah must have occurred in 2067-66 B.C. since it would have taken place in the year between the promise of Isaac's birth and the time of his birth when Abraham was age 99 (Gen 17).

This basic scheme is followed by others, including Gruenthaner, Bimson, Rasmussen, Ray, and Wood.⁷⁵ Bimson in particular rejects the LXX text of Exod 12:40, noting that "Abraham, Isaac and Jacob would hardly be described as 'children of Israel,'" and thus the text does not have their sojourn in Canaan in view (Bimson 1980: 83).

2350 B.C.

Finally, Freedman (1978b: 152) has made the suggestion that the patriarchs should be dated in the third millennium, in the EB III, which he places at approximately 2800-2400 B.C. The basis for this conclusion was a combination of early optimism regarding the appearance of the cities of the plain in the Ebla tablets (which was subsequently retracted, although the tablet in question has not been published) and the view that Bab edh-Dhra' and the other EB III sites along the southeastern rim of the Dead Sea likely were these same cities. Freedman rightly pointed out that MB sites in this region are lacking, a difficulty for an MB patriarchal period.

Freedman did not address the internal chronology of the OT. If Freedman's dates for the EB III were maintained, it would be necessary to posit some lacunae in the biblical numbers and genealogies in order to accommodate the additional centuries.

⁷⁵ Gruenthaner 1943: 87; Bimson 1980: 86; Rasmussen 1989: 79; Ray 1986: 239; Leon Wood 1986: 19-25, 387.

This view more recently has been endorsed by James Sauer (1994: 390), based in large part on the study of ancient climate. A similar suggestion has been made by Neev and Emery (1995), although apparently independently of Freedman and Sauer. Neev and Emery suggest dating the patriarchal period to approximately 2400-2200 B.C. in order to match the biblical data with the archaeological data (1995: 149). Although they believe that Sodom and Gomorrah were likely situated in the vicinity of Mt. Sedom on the southwestern shore of the Dead Sea, they identify Bab edh-Dhra' with Zoar and suggest a contemporary destruction due to earthquake activity. Again, no attempt is made to explain the numbers found in the biblical text.⁷⁶

Summary: Feasible Range of Schemes

Estimates for the age of the patriarchal period run from as early as 2350 to as late as the last part of the 15th century (fig. 41). The earliest and latest dates are the most difficult to reconcile with the biblical data. Because the early date of Freedman is based solely on the Ebla tablets (now seemingly discredited) and the possible connection to Bab edh-Dhra' and Numeira, it appears to lack an independent basis for our purposes. Likewise, the late-15th-century date of Gordon requires a fairly radical re-interpretation or outright dismissal of much of the biblical account. It appears much more likely that the patriarchs are to be located somewhere between the 22nd and 16th centuries B.C.

⁷⁶ Incidentally, Neev and Emery date the Exodus to about 1200 B.C., thus concluding that the sojourn in Egypt would have lasted about 1,000 years (1995: 150).

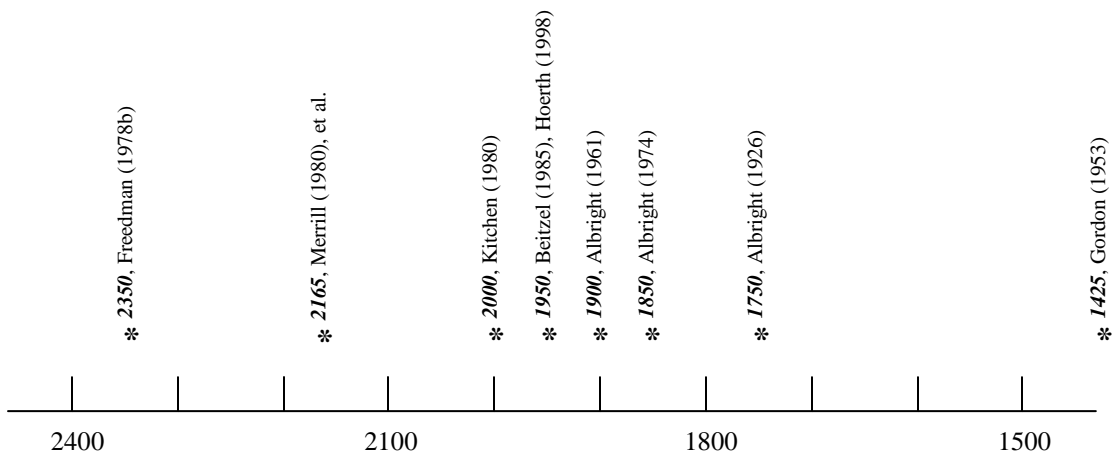

Fig. 41. Comparison of various dates suggested for the beginning of the patriarchal period (birth of Abraham).

CHAPTER 5

SUMMARY

Comparison of the Archaeological and Biblical Data

It now remains to propose a chronological scheme that ties together the evidence from Mesopotamia and Egypt with that of the Levant, and finally with the biblical evidence. Each will be addressed in turn.

Mesopotamia

For the Mesopotamian chronology from the Kassite period back through the Ur III period, the low chronology of Gasche et al. is adopted. Among the important dates of Gasche's scheme are the fall of Babylon in 1499 B.C., the reign of Hammurabi at 1696–1654, and the Ur III period at 2018–1911. The Ur III period was preceded by a time of unrest, described by the ancients as a time when one could ask, “Who was king? Who was not king?” Following Nissen, this period is assigned 45 years, and it is preceded by the Dynasty of Akkad at about 180 years and the Dynasty of Lagash at about 150 years (Nissen 1987).

The ultra-low chronology of Gasche et al. is allowed or supported by numerous other scholars (e.g., Veenhof 2000, Warburton 2002, Zeeb 2004, Novak 2007) and is reproduced in summary form in Appendix B. It is not necessary to use Gasche's scheme per se, but some form of a low or ultra-low chronology is necessary.

Egypt

For Egyptian chronology, particularly from the start of the New Kingdom back through Dynasty 6 in the Old Kingdom, I have followed the low chronology of Baines and Malek (2000). This is similar to the low chronology of Kitchen (2007), although Kitchen's preference is to begin the Middle Kingdom a bit earlier. Krauss (2007) estimates dates for these periods that are nearly identical to those of Baines and Malek, as do Hornung, Krauss, and Warburton (2006).⁷⁷ A summary of the dates for these periods according to Baines and Malek is provided in Appendix A.

The Levant

The dates for the Middle Bronze Age used in my scheme are largely based on those of Bietak and Höflmayer (2007). Bietak's Egyptian chronology is not particularly low. For example, he places the start of Sesostris III at 1873, whereas Baines and Malek place it nearly 40 years lower at 1836. Thus it would not be difficult to argue for an even lower chronology for the Levant as proposed by Yadin (1975) and Albright (1973). Bietak's view is espoused by others (e.g., D. Ben-Tor 2006, Porter 2005). It should be noted that Bietak prefers to give date ranges rather than a single date for the transitions between archaeological periods in the Levant. The length of the EB IV, here estimated at 160 years, is considered sufficient for the evidence known to date. As noted above, in some regions it seems to have been even shorter (Gophna 2009) and in other places it may overlap the EB III (Chapman 2009; Doumet-Serhal 2009) or the MB (Ilan 1998).

⁷⁷ It should be noted that the adoption of a low SIP or MK chronology does not require the lowest NK chronology. Bietak and Höflmayer (2007: 15) uses relatively high dates for Dyn 12 to urge a low MB IIA chronology.

The Patriarchs

The traditional long chronology for the sojourn and the patriarchal period is employed (e.g., Merrill 1986). As a result, the destruction of Sodom and Gomorrah, which occurred in Abraham's 99th year, is calculated to have occurred at 2066 (Gen 18:10, cf. Gen 21:5).

It should be noted that the chronologies outlined above generally do not comport well with ¹⁴C estimations. In fact, it is probably true that radiocarbon is the main issue that has, so far, prevented a broader acceptance of the lower chronologies.

The combination of these various chronologies—short chronologies for Mesopotamia, Egypt, and the Levant, and the traditional long chronology for the biblical patriarchs—is summarized on the chart in figure 42. This construction preserves the following synchronisms:

1. The synchronism between Hammurabi and Neferhetep (Dyn 13) in Egypt at around 1700 B.C. (see Albright 1945: 12; Kitchen 1987: 48)
2. The synchronism between Amenemmes II (Dyn 12) and the Ur III period, via cylinder seals (Albright 1973: 15), on the assumption that the Ur III is a contemporary or earlier
3. The appearance of Levantine Painted Ware (MB IIA) in levels associated with Sesostri III (mid to late Dyn 12; see Bietak and Kopetzky 2000: 127)
4. The appearance of a silver cup of the Ur III period in an EB IV tomb in Jerusalem (Dever 2003: 84)
5. Two seals apparently from the reign of Hammurabi, found in the palace of Khayan (Dyn 15) at Tel el-Dab'a (Artifax 2010), although the reign of Hammurabi would have preceded the reign of Khayan by two to three decades

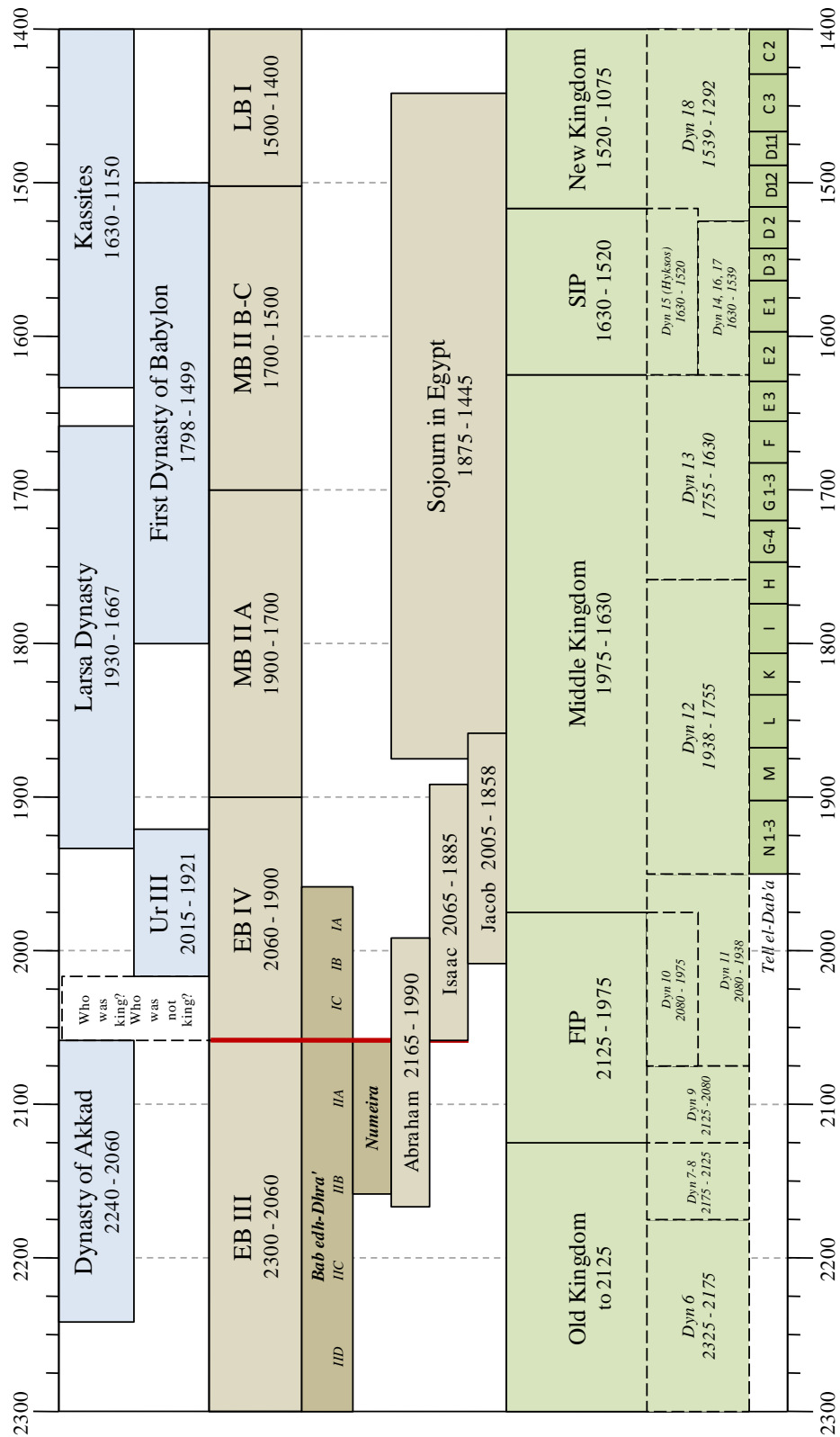

Fig. 42. Proposed chronological scheme for the Early Bronze–Middle Bronze period. Mesopotamian dates are largely those of Gasche et al. (1998: 91), with length of periods prior to Ur III as in Nissen (1987); Egyptian dates follow Baines and Malek (2000: 36). For the Levant, the end of EB IV through LB I follows Bietak (2007: 15).

6. The general or partial overlap between the EB IV and the FIP (e.g., Tufnell and Ward 1966, Oren 1973, Esse 1991, Redford 1992, Bietak and Höflmayer 2007, Prag 2009).

Implications for Biblical Chronology

There are, of course, numerous other issues at play besides the cities of the plain when constructing a biblical chronology. The length of the judges period, the date of the exodus and conquest, the length of the sojourn—all of these are legitimate issues on their own. However, the possible connection of the cities of the plain with Bab edh-Dhra' and Numeira would certainly tend to pull the biblical chronology higher rather than lower. The traditional high chronology is definitely the most attractive from this perspective.

For those who prefer the lower dates for the patriarchal and succeeding periods, other sites must be sought in this region that would match up with MB or LB periods. To date, very little from these periods has been found in this region, although it cannot be ruled out that future discoveries could yet change that picture.

Implications for Archaeology

Scholars working with absolute chronology in the Levant have always struggled with a lack of historical data for the earlier periods. There simply have not been more than a scattering of datable monuments, inscriptions, or other items like those found in Egypt and Mesopotamia which can tie historical figures and dates to archaeological levels, and those that have appeared have often been subject to debate because of questions of provenance or because they may have been kept as keepsakes (e.g., scarabs, seals, etc.). What has particularly been lacking has been a sequence of named rulers with associated monuments or architecture.

There is at least the potential that this could change if Bab edh-Dhra' and Numeira were to be positively identified as two of the cities of the plain. Such a link would mean that at long last a particular destruction level in the Levant could be identified as belonging to a known historical event in the Early Bronze Age. Although the destruction of the final EB III level at Bab edh-Dhra' and Numeira would not necessarily match up with the end of the EB III at other sites, it would provide the strongest link yet to historical events. Anchoring the end of the EB III at about 2060 B.C. would set parameters within which the succeeding periods would necessarily need to fit.

The combined impact of the invasion of the northern kings (Gen 14) and the overthrow of four important cities (Gen 19) would have had a devastating impact on the Dead Sea region. Might these events be part of the larger regional shift from the more urban EB III to the more pastoral EB IV?

This study has shown that it is chronologically possible that the EB III destructions of Bab edh-Dhra' and Numeira could be those described in Gen 19. A low EB III–IV chronology does overlap with a high patriarchal chronology. The archaeological chronology is not necessarily an impediment to such a match. Such a coincidence is not proven to be the case, but it is possible using a low archaeological chronology and a high (traditional) biblical chronology.

Several areas of future study are suggested in order to determine the likelihood that such an identification is correct.

Areas for Future Inquiry

Chronology

The raising of chronologies in Palestine during the last half-century needs to be reconsidered, especially in light of lowering trends in the chronologies of surrounding regions. The Levant seems to be a back-water in this regard. The lowering of Egyptian and Mesopotamian chronologies should pull down the dates of parallel periods in the Levant. If the connection between Bab edh-Dhra' and Numeira and the patriarchs is legitimate, the lengthened archaeological chronologies of recent decades should be abandoned in favor of lower chronologies.

Radiocarbon has yet to establish a reliable track record. It continues to be dogged by issues of consistency, accuracy, and precision in the historical periods, and thus its estimates for pre-historical eras must also be considered tentative. It seems that the physicists working with radiocarbon dating have much work yet to do if they wish to make lasting contributions to the reconstruction of the historical record. If more reliable, trustworthy, and precise results cannot be obtained within coming decades, perhaps the discipline should be abandoned altogether.

The identification of the four kings of the north (Gen 14) has remained something of a mystery. Attempts have been made to identify these kings in the records of ancient Mesopotamia, yet the search has typically been undertaken in the later periods (e.g., Gruenthaner 1943) and has proven unsuccessful. If the chronological scheme proposed here is correct, such a search should be moved back to about the end of the Dynasty of Akkad, rather than the Kassite period.

Exploration in the Southern Ghor

It would be very interesting to continue this study by taking the next logical step in trying to work out the possible interconnection between the biblical accounts and the remains at Bab edh-Dhra' and Numeira. Some initial work in this regard has already been done (e.g., Wood 1999). Could specific destruction layers be attributed to the battle of the four kings against five (Gen 14) or to the final overthrow of the cities (Gen 19)? What can be made of the post-destruction settlement (EB IV) at Bab edh-Dhra? From the biblical perspective, Sodom had a gate (Gen 19:1) and presumably walls, as was true at both Bab edh-Dhra' and Numeira, but this was not necessarily true of the other cities of the plain. What might explain the blocked doorways and gates of the final occupational level? The idea that the destruction of Numeira, which included "massive burning," was caused by a "natural cause such as an earthquake" (Rast 2003: 327) does not explain all the data. How is it that the inhabitants had time to block up doors with stone yet left behind grain and grapes that were carbonized before being destroyed by rodents?

Further research into the possible location and identification of the other "cities of the plain" would be merited. Only scanty remains have been found at es-Safi and Feifa so far. "Early Bronze IB burials in cist tombs were found in large cemeteries at both es-Safi and Feifa, but no evidence of settlement remains appeared at either site, suggesting that here the pastoralist life-style remained intact and was not transformed as at Bab edh-Dhra'" (Rast 2003: 324). At Khirbet Khanazir only EB IV tombs have been found, and no domestic structures have been identified (MacDonald 1995). However, it is good to recall Albright's initial conclusions: Even after excavations at Bab edh-Dhra' he concluded that no city had existed there, and his team completely missed the city at Numeira. Similarly, only recently has the huge Iron Age copper mining site at Jabal al-

Jariya been discovered, despite the fact that the region has been surveyed many times before and it is located next to the well-known Faynan mines (Ben-Yosef, Levy, and Najjar 2009). As Albright observed long ago, the water sources in this region would each have been capable of supporting a town, and cultivable alluvial fans are spread around the southern end of the Dead Sea (Neev and Emery 1995: 108-111, esp. fig. 4.15). Thus an energetic search for Early Bronze towns somewhere along their courses is merited. EB III settlements would be expected along these water courses and alluvial fans, whether or not Bab edh-Dhra' and Numeira are in fact two of the biblical "cities of the plain."

APPENDIX A

RULERS OF EGYPT

Rulers of Egypt according to Baines and Malek (2000: 36).

<p>LATE PREDYNASTIC c. 3100 "Dynasty 0" Several kings; Iryhor(?); Ka(?); Na'mer</p> <p>EARLY DYNASTIC PERIOD c. 2950-2775 c. 2950-2775 Menes (= Aha?); Djer; Wadj; Den; 'Ane'djib; Semerkhet; Qa'a</p> <p>2nd Dynasty c. 2775-2650 Hotepsekhemw; Re'neb; Ninetjer; Peribsen; Kha'sekhem(wy)</p> <p>3rd Dynasty c. 2650-2575 Djoser (Netjerikhet) Sekhemkhet Zanakht (=Nebka?) Kha'ba Huni(?)</p>	<p>1st INTERMEDIATE PERIOD c. 2125-1975 c. 2125-2080 9th Dynasty (Herakleopolitan)</p> <p>10th Dynasty c. 2080-1975 (Herakleopolitan) Several kings called Kheby; Merykare'; Ity</p> <p>11th Dynasty c. 2080-1975 (Theban) Inyotef I (Sehertawy) Inyotef II (Wah' ankh) Inyotef III (Nakhtnebtupfer) Nebhepetre' Mentuhotep</p> <p>MIDDLE KINGDOM c. 1975-1640 c. 1975-1940 11th Dynasty (all Egypt) Nebhepetre' Mentuhotep S'ankhkare' Mentuhotep Nebtawyre' Mentuhotep c. 1948-?</p> <p>12th Dynasty c. 1938-1755 c. 1938-1908 Amenemhet I (Sehetepibre') Senwosret I (Kheperkare') (Nubkaure') Senwosret II (Kha'kheperre') Senwosret III (Kha'kaure') Amenemhet III (Nima'atre') Amenemhet IV (Ma'akheperre') Neferusobk (Sebekkare')</p> <p>13th DYNASTY c. 1755-1630 About 70 kings; better-known ones are listed (numbers are their approximate positions in a complete list)</p>	<p>Wegaf ('Khatuwyre') 1; Amenemhet V ('Sekhemkare') 4; Harnedjheritof ('Hetepibre') 9; Amenyemau I Ib Sebekhotep I c. 1725 (Kha'ankhre') 12; Hor ('Awibre') 14; Amenemhet VII ('Sedjefakare') 15; Sebekhotep II ('Sekhemre'-khatuw) 16; Khendjer ('Userkare') 17; Sebekhotep III ('Sekhemre'-swadjtawy) 21; Neferhotep I c. 1710-1700 (Khasekhmerre') 22 Sebekhotep IV c. 1700-1690 (Kha'feferre) 24 Sebekhotep V c. 1690-1685 (Kha'hotepre') 25 Aya c. 1685-1670 (Mernferre') 27 Mentue mza' ('Djed'ankhre') 32c Dedumose II ('Djedneferre') 37; Neferhotep III ('Sekhemre'-s'ankhatawy) 41a</p> <p>14th Dynasty Minor kings who were probably all contemporaneous with the 13th or 15th Dynasties</p> <p>2nd INTERMEDIATE PERIOD c. 1630-1520 15th Dynasty (Hyksos) c. 1630-1520 Salitis; Sheshi; Khian ('Swoseremre') Apophis c. 1570-1530 (A'woserre' and others) Khamudi c. 1530-1520</p> <p>16th Dynasty Minor Hyksos rulers, contemporaneous with the 15th Dynasty</p> <p>17th Dynasty c. 1630-1540 Numerous Theban kings; numbers give positions in a complete list Inyotef V ('Nubkheperre') 1; Sebekemza'af ('Sekhemre' - wadjkha' 'u) 3; Nebireyraw ('Swadjenre') 6; Sebekemza'af II ('Sekhemre'-shedtawy) 10; Ta'o (or Djehuti' o) I ('Senekhtenre') 13;</p>	<p>Ta'o (or Djehuti' o) II ('Sekhemre'-swadjtawy) 14 Kamose (Wadjkheperre') 15</p> <p>NEW KINGDOM c. 1539-1075 18th Dynasty 'Ahmose c. 1539-1514 (Userkheperre') Amenhotep I ('Djeserkare') c. 1514-1493 (Djeserkare') c. 1493-? Thutmose I ('Akheperkare') c. ?-1479 (Thutmose II ('Akheperenre') c. 1479-1425 Thutmose III ('Menkheperre') c. 1473-1458 Hatshepsut ('Ma'arkare') Q c. 1426-1400 Amenhotep II ('Akheprure') c. 1400-1390 Thutmose IV ('Menkheperre') c. 1390-1353 Amenhotep III ('Nebma'atre') c. 1353-1336 Amenhotep IV ('Akhenaten ('Neferkheprure' wa' enre') c. 1335-1332 Smenkhkare' ('Ankheprure') c. 1332-1322 Tut'ankhamun ('Nebkheprure') c. 1322-1319 Aya ('Kheperkheprure') c. 1319-1292 Haremhab ('Djeserkheprure')</p> <p>19th Dynasty c. 1292-1190 Rameses I c. 1292-1290 (Mernptire') c. 1290-1279 Sety I ('Menma'atre') c. 1279-1213 Rameses II ('Userma'atre' setepenre') c. 1213-1204 Mernepthah ('Baenre' hotepihirma'at) c. 1204-1198 Sety II ('Userkheprure' setepenre') c. 945-925 Anemnesse ('Mennire'), usurper during reign of Sety II</p>	<p>Siptah ('Akhenre' setepenre') c. 1198-1193 Twosre c. 1198-1190 (Sitre' meritamun) Q</p> <p>20th Dynasty c. 1190-1075 Sethnakhte ('Userkha'ure' meryamun) c. 1187-1156 Rameses III ('Userma'atre' meryamun) c. 1156-1150 Rameses IV ('Heqama'atre' setepenamun) c. 1150-1145 Rameses V ('Userma'atre' sekheperenre') c. 1145-1137 Rameses VI ('Nebma'atre' meryamun) c. 1137-1129 Rameses VII ('Userma'atre' setepenre' meryamun) c. 1129-1126 Rameses VIII ('Userma'atre' akhenamun) c. 1126-1108 Rameses IX ('Neferkare' setepenre') c. 1108-1104 Rameses X c. 1104-1075 Rameses XI ('Menma'atre' setepenptah)</p> <p>3rd INTERMEDIATE PERIOD c. 1075-715 21st Dynasty c. 1075-945 Smenides ('Hedjkheperre' setepenre') c. 1050-1040 Amenemnisu ('Neferkare') c. 1040-995 Psusennes I ('Akheperre' setepenamun) c. 994-985 Amenemope ('Userma'atre' setepenamun) c. 985-978 Osorkon I ('Akheperre' setepenre') c. 978-960 Siamun ('Neferkheperre' setepenamun) c. 960-945 Psusennes II ('Ttikheprure' setepenre')</p> <p>22nd Dynasty c. 945-715 Shoshenq I ('Hedjkheperre' setepenre') c. 945-925 Shoshenq II ('Hedjkheperre' setepenre') c. 925-910 Osorkon II ('Sekhemkheperre' setepenre')</p>
--	---	---	--	---

APPENDIX B

MESOPOTAMIAN CHRONOLOGY

Chart of Mesopotamian Chronology according to Gasche et al. (1998: 91).

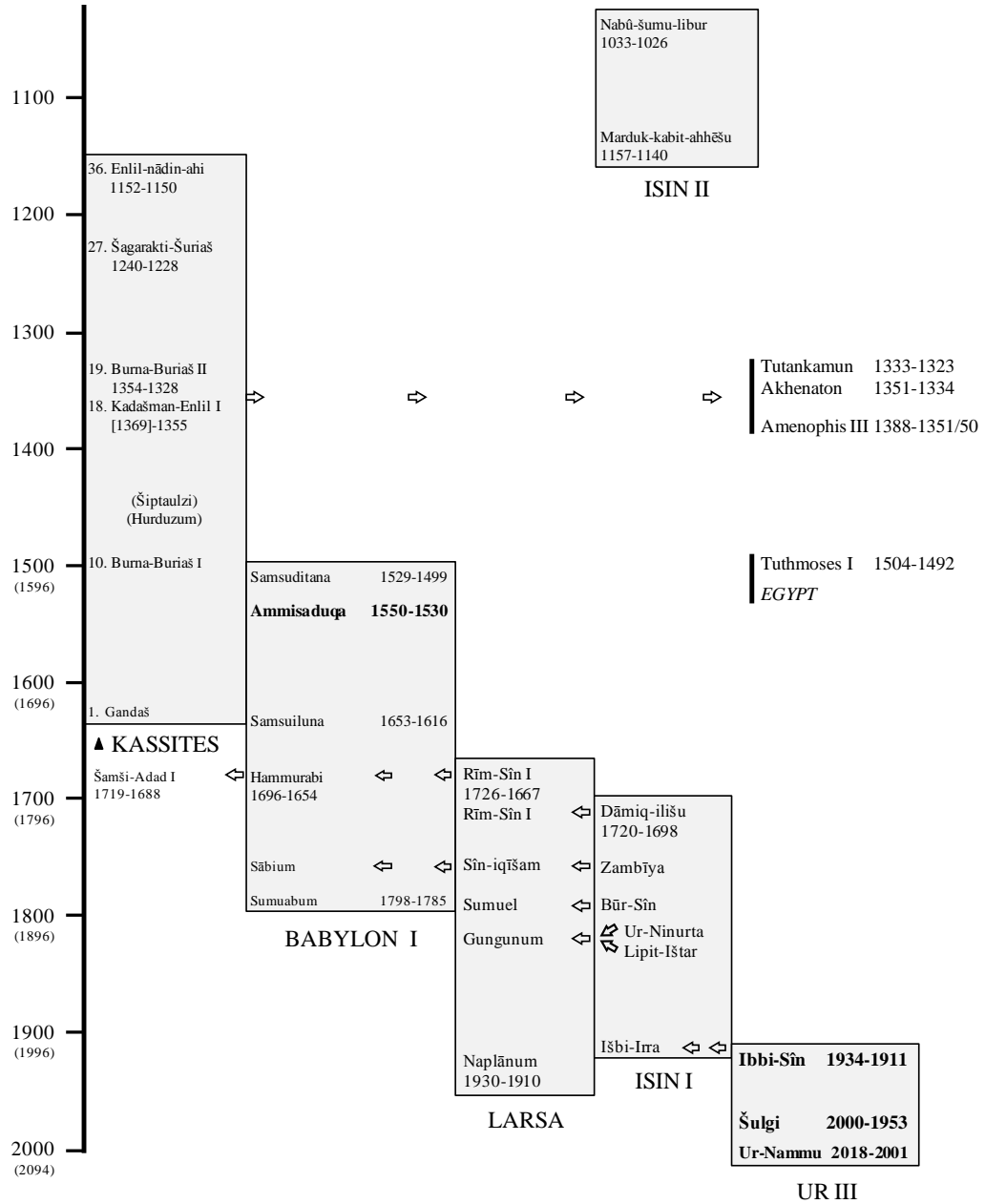

Principal Southern Mesopotamian Dynasties of the Second Millennium and Their Dating

(1596) (2094) Middle Chronology dates.
 ⇐ Synchronism (or indirect synchr. [Sîn-iqīšam/Šabium]).

BIBLIOGRAPHY

BIBLIOGRAPHY

- Aardsma, G. E.
1989 Myths Regarding Radiocarbon Dating. *Impact* no. 189.
2001 New Radiocarbon Dates for the Reed Mat from the Cave of the Treasure, Israel. *Radiocarbon* 43 no. 2: 1247-54.
- Adams, R. B.
2000 The Early Bronze Age III-IV Transition in Southern Jordan: Evidence from Khirbet Hamra Ifdan. Pp. 379-401 in *Ceramics and Change in the Early Bronze Age of the Southern Levant*. Levantine Archaeology, 2, eds. G. Philip and D. Baird. Sheffield: Sheffield Academic Press.
- Aharoni, Y.
1982 *The Archaeology of the Land of Israel*, from A. F. Rainey. Philadelphia: Westminster Press.
- Aharoni, Y., Avi-Yonah, M., Rainey, A. F., and Safrai, Z.
1993 *The Macmillan Bible Atlas*. New York: Macmillan.
- Ahlström, G. W.
1994 *The History of Ancient Palestine*. Minneapolis: Fortress Press.
- Albright, W. F.
1926 The Jordan Valley in the Bronze Age. *Annual of the American Schools of Oriental Research* 6: 13-74.
1932a The Excavation of Tell Beit Mirsim in Palestine. *Annual of the American Schools of Oriental Research* 12.
1932b The Fourth Joint Campaign of Excavations at Tell Beit Mirsim. *Bulletin of the American Schools of Oriental Research* 47: 3-17.
1945 An Indirect Synchronism Between Egypt and Mesopotamia, Cir. 1730 B.C. *Bulletin of the American Schools of Oriental Research* 99: 9-18.
1956 Stratigraphic Confirmation of the Low Mesopotamian Chronology. *Bulletin of the American Schools of Oriental Research* 144: 26-30.

- 1961 Abraham the Hebrew: A New Archaeological Interpretation. *Bulletin of the American Schools of Oriental Research* 163: 36-54.
- 1973 The Historical Framework of Palestinian Archaeology between 2100 and 1600 B.C. (E.B. IV, M.B. I, M.B. IIA-B). *Bulletin of the American Schools of Oriental Research* 209: 12-18.
- 1974 *The Archaeology of Palestine and the Bible*. The Richards Lectures delivered at the University of Virginia. Cambridge, MA: American Schools of Oriental Research.
- Albright, W. F., Kelso, J. L., and Thorley, J. P.
 1944 Early Bronze Pottery from Bab ed-Dra' in Moab. *Bulletin of the American Schools of Oriental Research* 95: 3-11.
- Aldred, C.
 1998 *The Egyptians*. London: Thames and Hudson.
- Aling, C. F.
 1981 *Egypt and Bible History: From Earliest Times to 1000 B.C.* Grand Rapids: Baker.
- Amiran, R.
 1960 Pottery of the Middle Bronze Age I in Palestine. *Israel Exploration Journal* 10: 204-25.
 1968 Similarities Between the Pottery of the MB IIA Period and the Pottery of the Assyrian Colonies, and Their Implications. *Anatolia* 12: 59-66.
 1969 *Ancient Pottery of the Holy Land*. Jerusalem: Massada Press.
- Arnold, J. R., and Libby, W. F.
 1949 Age Determinations by Radiocarbon Content: Checks with Samples of Known Age. *Science* 110: 678-80.
- Artifax
 2010 Hammurabi Period Seal Discovered in Egypt. *Artifax Winter*: 20.
- Astour, M. C.
 1979 Yahweh in Egyptian Topographic Lists. Pp. 17-33 in *Festschrift Elmar Edel*, eds. M. Görg and E. Pusch. Bamberg: Manfred Görg.

- Åström, P.
 1989 High, Middle or Low? Final Conclusions. Pp. 75-77 in *High, Middle or Low? Acts of an International Colloquium on Absolute Chronology Held at the University of Göthenburge 20th-22nd August 1987: Part 3*, ed. P. Åström. Göthenburg: Åström.
- 2000 Cyprus. Pp. 150-53 in *The Synchronisation of Civilisations in the Eastern Mediterranean in the Second Millennium B.C.: Proceedings of an International Symposium at Schloß Haindorf, 15th-17th of November 1996 and at the Austrian Academy, Vienna, 11th-12th of May 1998*. Contributions to the Chronology of the Eastern Mediterranean, Vol. 1, ed. M. Bietak. Vienna, Austria: Österreichischen Akademie der Wissenschaften.
- 2007 Sinda and the Absolute Chronology of Late Cypriote IIIA. Pp. 505-7 in *The Synchronisation of Civilisations in the Eastern Mediterranean in the Second Millennium B.C. III: Proceedings of the SCIEM 2000-2nd EuroConference, Vienna, 28th of May-1st of June 2003*. Contributions to the Chronology of the Eastern Mediterranean, Vol. 9, eds. M. Bietak and E. Czerny. Vienna, Austria: Österreichischen Akademie der Wissenschaften.
- Avner, U., and Carmi, I.
 2001 Settlement Patterns in the Southern Levant Deserts During the 6th-3rd Millian BC: A Revision Based on ¹⁴C Dating. *Radiocarbon* 43 no. 3: 1203-16.
- Bagh, T.
 2002 Painted Pottery at the Beginning of the Middle Bronze Age: Levantine Painted Ware. Pp. 89-101 in *The Middle Bronze Age in the Levant*, ed. M. Bietak. Vienna: Österreichische Akademie der Wissenschaften.
- Baillie, M. G. L.
 1990 Difficulties Associated with any Radical Revision of Egyptian Chronology: A Reply to Bernard Newgrosh. *Journal of the Ancient Chronology Forum* 3: 29-36.
- Baillie, M. G. L., and Pilcher, J. R.
 1983 Some Observations on the High-Precision Calibration of Routine Dates. Pp. 51-63 in *Archaeology, Dendrochronology, and the Radiocarbon Calibration Curve*, ed. B. S. Ottaway. Edinburgh: University of Edinburgh.
- Baines, J., and Malek, J.
 2000 *Cultural Atlas of Ancient Egypt*. New York: Checkmark Books.

- Banning, E. B.
 2001 Review of *Neolithic and Chalcolithic Pottery of the Southern Levant* by Yosef Garfinkel, Qedem 39, 1999. *Bulletin of the American Schools of Oriental Research* 322: 79-81.
- 2003 Archaeological Survey in the Southern Levant. Pp. 164-7 in *Near Eastern Archaeology: A Reader*, ed. S. Richard. Winona Lake: Eisenbrauns.
- Beitzel, B. J.
 1985 *The Moody Atlas of Bible Lands*. Chicago: Moody Press.
- Bennett, C.
 1980 Soundings at Dhra, Jordan. *Levant* 12: 30-39.
- Ben-Tor, A.
 1982 The Relations Between Egypt and the Land of Canaan During the Third Millennium B.C. *Journal of Jewish Studies* 33: 3-18.
- 1992 The Early Bronze Age. Pp. 81-125 in *The Archaeology of Ancient Israel*, ed. A. Ben-Tor, from R. Greenberg. New Haven: Yale University Press.
- Ben-Tor, D.
 2003 Egyptian-Levantine Relations and Chronology in the Middle Bronze Age: Scarab Research. Pp. 239-48 in *The Synchronisation of Civilisations in the Eastern Mediterranean in the Second Millennium B.C. II: Proceedings of the SCIEM 2000–EuroConference, Haindorf, 2nd of May–7th of May 2001*, ed. M. Bietak. Vienna, Austria: Österreichischen Akademie der Wissenschaften.
- 2006 Egyptian Reference Points and the Low Chronology for the Middle Bronze Age. <http://www.biu.ac.il/js/le/mb/ABSTRACTS/BENTOR00.htm>
- Ben-Yosef, E., Levy, T. E., and Najjar, M.
 2009 New Iron Age Copper-Mine Fields Discovered in Southern Jordan. *Near Eastern Archaeology* 72 no. 2: 98-101.
- Bichler, M., Exler, M., Peltz, C., and Saminger, S.
 2003 Thera Ashes. Pp. 11-21 in *The Synchronisation of Civilisations in the Eastern Mediterranean in the Second Millennium B.C. II: Proceedings of the SCIEM 2000–EuroConference, Haindorf, 2nd of May–7th of May 2001*, ed. M. Bietak. Vienna, Austria: Österreichischen Akademie der Wissenschaften.

Bietak, M.

- 1984 Problems of Middle Bronze Age Chronology: New Evidence from Egypt. *American Journal of Archaeology* 88 no. 4: 471-85.
- 1989 The Middle Bronze Age of the Levant - A New Approach to Relative and Absolute Chronology. Pp. 78-120 in *High, Middle or Low? Acts of an International Colloquium on Absolute Chronology Held at the University of Göthenburge 20th-22nd August 1987: Part 3*, ed. P. Åström. Göthenburg: Åström.
- 1996 *Avaris: The Capital of the Hyksos*. London: British Museum Press.
- 2000 Datelines According to the First Appearance of Frequent Artefacts with Wide Distribution. Pp. 27-9 in *The Synchronisation of Civilisations in the Eastern Mediterranean in the Second Millennium B.C.: Proceedings of an International Symposium at Schloß Haindorf, 15th–17th of November 1996 and at the Austrian Academy, Vienna, 11th–12th of May 1998*. Contributions to the Chronology of the Eastern Mediterranean, Vol. 1, ed. M. Bietak. Vienna, Austria: Österreichischen Akademie der Wissenschaften.
- 2002 Relative and Absolute Chronology of the Middle Bronze Age: Comments on the Present State of Research. Pp. 29-42 in *The Middle Bronze Age in the Levant*, ed. M. Bietak. Vienna: Österreichische Akademie der Wissenschaften.
- 2003a Israelites Found In Egypt. *Biblical Archaeology Review* 29 no. 5: 40-49, 82-3.
- 2003b Science versus Archaeology: Problems and Consequences of High Aegean Chronology. Pp. 23-33 in *The Synchronisation of Civilisations in the Eastern Mediterranean in the Second Millennium B.C. II: Proceedings of the SCIEM 2000–EuroConference, Haindorf, 2nd of May –7th of May 2001*, ed. M. Bietak. Vienna, Austria: Österreichischen Akademie der Wissenschaften.

Bietak, M., and Hein, I.

- 2001 The Context of White Slip Wares in the Stratigraphy of Tell el-Dab‘a and some Conclusions on Aegean Chronology. Pp. 171-94 in *The White Slip Ware of Late Bronze Cyprus: Proceedings of an International Conference Organized by the Anastasios G. Leventis Foundation, Nicosia, in Honour of Malcolm Viennaer, Nicosia, 29th-30th October 1998*. Contributions to the Chronology of the Eastern Mediterranean, Vol. 2, ed. V. Karageorghis. Vienna: Österreichischen Akademie der Wissenschaften.

- Bietak, M., and Höflmayer, F.
 2007 Introduction: High and Low Chronology. Pp. 13-23 in *The Synchronisation of Civilisations in the Eastern Mediterranean in the Second Millennium B.C. III: Proceedings of the SCIEM 2000–2nd EuroConference, Vienna, 28th of May–1st of June 2003*. Contributions to the Chronology of the Eastern Mediterranean, Vol. 9, eds. M. Bietak and E. Czerny. Vienna, Austria: Österreichischen Akademie der Wissenschaften.
- Bietak, M., and Kopetzky, K.
 2000 Regional Projects: Israel/Palestine. Pp. 96-129 in *The Synchronisation of Civilisations in the Eastern Mediterranean in the Second Millennium B.C.: Proceedings of an International Symposium at Schloß Haindorf, 15th–17th of November 1996 and at the Austrian Academy, Vienna, 11th–12th of May 1998*. Contributions to the Chronology of the Eastern Mediterranean, Vol. 1, ed. M. Bietak. Vienna, Austria: Österreichischen Akademie der Wissenschaften.
- Bietak, M., Kopetzky, K., Stager, L. E., and Voss, R.
 2008 Synchronisation of Stratigraphies: Ashkelon and Tell el-Dab‘a. Pp. 49-60 in *Egypt and the Levant 18*, ed. M. Bietak. Vienna: Österreichische Akademie der Wissenschaften.
- Billington, C. E.
 2007 Goliath and the Exodus Giants: How Tall Were They? *Journal of the Evangelical Theological Society* 50 no. 3: 489-508.
- Bimson, J. J.
 1980 Archaeological Data and The Dating of the Patriarchs. Pp. 53-89 in *Essays on the Patriarchal Narratives*, eds. A. R. Millard and D. J. Wiseman. Winona Lake, IN: Eisenbrauns.
- Bonani, G., Broshi, M., Carmi, I., Ivy, S., Strugnell, J., and Wölfli, W.
 1991 Radiocarbon Dating of the Dead Sea Scrolls. *Atiqot* 20: 27-32.
- Bonani, G., Haas, H., Hawass, Z., Lehner, M., Nakhla, S., Nolan, J., Wenke, R., and Wölfli, W.
 2001 Radiocarbon Dates of Old and Middle Kingdom Monuments in Egypt. *Radiocarbon* 43 no. 2: 1297-320.
- Borowski, O.
 1988 Ceramic Dating. Pp. 223-33 in *Benchmarks in Time and Culture: An Introduction to Palestinian Archaeology. Essays in Honor of Joseph A. Callaway*. Archaeology and Biblical Studies/Society of Biblical Literature; no. 1, eds. J. F. Drinkard, G. L. Mattingly, J. M. Miller, and J. A. Callaway. Atlanta: Scholars Press.

- Braun, E.
 1993 Some Observations on the Origins and Iconography of a Cylinder Seal from Bab edh-Dhra'. *Bulletin of the American Schools of Oriental Research* 290-291: 121-25.
- 2001 Proto, Early Dynastic Egypt, and Early Bronze I-II of the Southern Levant: Some Uneasy ¹⁴C Correlations. *Radiocarbon* 43 no. 2: 1279-95.
- 2006 Review of "Bab edh-Dhra': Excavations at the Town Site (1975-1981), Part 1. Text; Part 2. Plates and Appendixes; Reports of the Expedition to the Dead Sea Plain, Jordan, Vol. 2, by W.E. Rast and R.T. Schaub, *Israel Exploration Journal* 56 no. 2: 242-51.
- Breasted, J. H.
 1906 *Ancient Records of Egypt*. New York: Russell & Russell.
- Brein, G.
 2000 Astrochronology and Ancient Egyptian Chronology. Pp. 53-6 in *The Synchronisation of Civilisations in the Eastern Mediterranean in the Second Millennium B.C.: Proceedings of an International Symposium at Schloß Haindorf, 15th-17th of November 1996 and at the Austrian Academy, Vienna, 11th-12th of May 1998*. Contributions to the Chronology of the Eastern Mediterranean, Vol. 1, ed. M. Bietak. Vienna, Austria: Österreichischen Akademie der Wissenschaften.
- Bruins, H. J.
 1994 Comparative Chronology of Climate and Human History in the Southern Levant from the Late Chalcolithic to the Early Arab Period. Pp. 301-14 in *Late Quaternary Chronology and Paleoclimates of the Eastern Mediterranean*, eds. O. Bar-Yosef and R. S. Kra. Tuscon: University of Arizona.
- 2007 Charcoal Radiocarbon Dates of Tell el-Dab'a. Pp. 65-77 in *The Synchronisation of Civilisations in the Eastern Mediterranean in the Second Millennium B.C. III: Proceedings of the SCIEM 2000-2nd EuroConference, Vienna, 28th of May-1st of June 2003*. Contributions to the Chronology of the Eastern Mediterranean, Vol. 9, eds. M. Bietak and E. Czerny. Vienna, Austria: Österreichischen Akademie der Wissenschaften.
- 2010 Dating Pharaonic Egypt. *Science* 328: 1489-90.

Bruins, H. J., Mazar, A., and van der Plicht, J.

- 2007 The End of the 2nd Millennium BCE and the Transition from Iron I to Iron IIA: Radiocarbon Dates of Tel Rehov, Israel. Pp. 79-99 in *The Synchronisation of Civilisations in the Eastern Mediterranean in the Second Millennium B.C. III: Proceedings of the SCIEM 2000–2nd EuroConference, Vienna, 28th of May–1st of June 2003*. Contributions to the Chronology of the Eastern Mediterranean, Vol. 9, eds. M. Bietak and E. Czerny. Vienna, Austria: Österreichischen Akademie der Wissenschaften.

Bruins, H. J., and van der Plicht, J.

- 1995 Tell Es-Sultan (Jericho): Radiocarbon Results of Short-lived Cereal and Multiyear Charcoal Samples from the End of the Middle Bronze Age. *Radiocarbon* 37: 213-20.
- 1998 Early Bronze Jericho: High-Precision ¹⁴C Dates of Short-lived Palaeobotanic Remains. *Radiocarbon* 40 no. 2: 621-28.
- 2001 Radiocarbon Challenges Archaeo-Historical Time Frameworks in the Near East: The Early Bronze Age of Jericho in Relation to Egypt. *Radiocarbon* 43 no. 2: 1321-32.
- 2003 Assorting and Synchronising Archaeological and Geological Strata with Radiocarbon: the Southern Levant in Relation to Egypt and Thera. Pp. 35-42 in *The Synchronisation of Civilisations in the Eastern Mediterranean in the Second Millennium B.C. II: Proceedings of the SCIEM 2000–EuroConference, Haindorf, 2nd of May–7th of May 2001*, ed. M. Bietak. Vienna, Austria: Österreichischen Akademie der Wissenschaften.
- 2004 Desert Settlement in the Central Negev: First ¹⁴C Indication of Rainwater-Harvesting Agriculture in the Iron Age. Pp. 83-98 in *Radiocarbon and Archaeology: Proceedings of the 4th Symposium, Oxford 2002*. Oxford University School of Archaeology Monograph 62, eds. T. F. G. Higham, C. Bronk Ramsey, and C. Owen. Oxford: Oxford University School of Archaeology.

Bruins, H. J., van der Plicht, J., and Mazar, A.

- 2003a ¹⁴C Dates from Tel Rehov: Iron-Age Chronology, Pharaohs, and Hebrew Kings. *Science* 300: 315-18.
- 2003b Response to Comment on "¹⁴C Dates from Tel Rehov: Iron-Age Chronology, Pharaohs, and Hebrew Kings." *Science* 302: 568c.

- Cadogan, G., Herscher, E., Russell, P., and Manning, S. W.
 2001 Maroni-Vournes: A Long White Slip Sequence and its Chronology. Pp. 75-88 in *The White Slip Ware of Late Bronze Cyprus: Proceedings of an International Conference Organized by the Anastasios G. Leventis Foundation, Nicosia, in Honour of Malcolm Viennaer, Nicosia, 29th-30th October 1998*. Contributions to the Chronology of the Eastern Mediterranean, Vol. 2, ed. V. Karageorghis. Vienna: Österreichischen Akademie der Wissenschaften.
- Callaway, J. A.
 1985 Was My Excavation of Ai Worthwhile? *Biblical Archaeology Review* 11 no. 2: 68-9.
- Callaway, J. A., Schoonover, K., and Ellinger, W. W.
 1980 *The Early Bronze Age Citadel and Lower City at Ai (et-Tell)*. Excavation Reports. Cambridge, MA: American Schools of Oriental Research.
- Callaway, J. A., and Weinstein, J. M.
 1977 Radiocarbon Dating of Palestine in the Early Bronze Age. *Bulletin of the American Schools of Oriental Research* 225: 1-16.
- Chapman, R. L.
 2009 Early Bronze III and IV: Chronological and Cultural Relations. Pp. 1-8 in *The Levant in Transition*. The Palestine Exploration Fund Annual 9, ed. P. J. Parr. Leeds: Maney.
- Chesson, M.
 1999 Libraries of the Dead: Early Bronze Age Charnel Houses and Social Identity at Urban Bab edh-Dhra', Jordan. *Journal of Anthropological Archaeology* 18: 137-64.
- Cichocki, O.
 2000 Dating Wooden Objects from the Eastern Mediterranean in the Second Millennium B.C. Pp. 62-7 in *The Synchronisation of Civilisations in the Eastern Mediterranean in the Second Millennium B.C.: Proceedings of an International Symposium at Schloß Haindorf, 15th-17th of November 1996 and at the Austrian Academy, Vienna, 11th-12th of May 1998*. Contributions to the Chronology of the Eastern Mediterranean, Vol. 1, ed. M. Bietak. Vienna, Austria: Österreichischen Akademie der Wissenschaften.

- 2003 Dendrochronological Investigations on Cedar Objects of Ancient Egypt. Pp. 43-6 in *The Synchronisation of Civilisations in the Eastern Mediterranean in the Second Millennium B.C. II: Proceedings of the SCIEM 2000–EuroConference, Haindorf, 2nd of May–7th of May 2001*, ed. M. Bietak. Vienna, Austria: Österreichischen Akademie der Wissenschaften.
- Cichocki, O.
2006 Dendrochronology. Pp. 361-68 in *Ancient Egyptian Chronology*, eds. E. Hornung, R. Krauss, and D. A. Warburton. Boston: Brill.
- Clapp, F. G.
1936 The Site of Sodom and Gomorrah. *American Journal of Archaeology* 40: 323-44.
- Cohen, S. L.
2002 *Canaanites, Chronologies, and Connection: The Relationship of Middle Bronze IIA Canaan to Middle Kingdom Egypt*. Studies in the Archaeology and History of the Levant. Winona Lake, IN: Eisenbrauns.
- Collins, S.
2002 The Geography of the Cities of the Plain. *Biblical Research Bulletin* 2 no. 1: 1-17.
2007 Sodom: The Discovery of a Lost City. *Bible and Spade* 20 no. 3: 70-77.
- Coogan, M. D.
1984 Numeira 1981. *Bulletin of the American Schools of Oriental Research* 255: 75-81.
- Currid, J. D.
1997 *Ancient Egypt and the Old Testament*. Grand Rapids: Baker.
- Currie, L. A.
2004 The Remarkable Metrological History of Radiocarbon Dating [II]. *Journal of Research of the National Institute of Standards and Technology* 109 no. 2: 185-217.
- Dalman, R.
2008 Egypt and Early Israel's Cultural Setting: A Quest for Evidential Possibilities. *Journal of the Evangelical Theological Society* 51 no. 3: 449-88.

- de Miroschedji, P.
- 1989 Le Processus d'urbanisation en Palestine au Bronze ancien: Chronologie et Rythmes. Pp. 63-79 in *L'Urbanisation de la Palestine à l'âge du Bronze ancien : Bilan et perspectives des recherches actuelles : Actes du Colloque d'Emmaüs, 20-24 octobre 1986. BAR International Series; 527*, Vol. 1, ed. P. de Miroschedji. Oxford: B.A.R.
- 2000 An Early Bronze Age III Pottery Sequence for Southern Israel. Pp. 315-45 in *Ceramics and Change in the Early Bronze Age of the Southern Levant*. *Levantine Archaeology*; 2, eds. G. Philip and D. Baird. Sheffield: Sheffield Academic Press.
- de Vaux, R.
- 1971 Palestine in the Early Bronze Age. Pp. 208-37 in *The Cambridge Ancient History*, Vol. 1, pt. 2, 3rd ed. Cambridge: Cambridge University Press.
- 1972 *The Bible and the Ancient Near East*. London: Darton, Longman & Todd.
- Dever, W. G.
- 1973 The EB IV-MB I Horizon in Transjordan and Southern Palestine. *Bulletin of the American Schools of Oriental Research* 210: 37-63.
- 1977 The Patriarchal Traditions. Pp. 70-148 in *Israelite and Judean History*, eds. J. H. Hayes and J. M. Miller. Philadelphia: Westminster.
- 1980a Editorial. *Bulletin of the American Schools of Oriental Research* 237: 1-4.
- 1980b New Vistas on the EB IV ("MB I") Horizon in Syria-Palestine. *Bulletin of the American Schools of Oriental Research* 237: 35-64.
- 1987 The Middle Bronze Age: The Zenith of the Urban Canaanite Era. *Biblical Archaeologist* 50: 148-77.
- 1992 The Chronology of Syria-Palestine in the Second Millennium B.C.E.: A Review of the Current Issues. *Bulletin of the American Schools of Oriental Research* 288: 1-25.
- 1995 Ceramics, Ethnicity, and the Question of Israel's Origin. *Biblical Archaeologist* 58 no. 4: 200-13.
- 1998 Social Structure in the Early Bronze IV Period in Palestine. Pp. 282-96 in *The Archaeology of Society in the Holy Land*, 2nd ed., ed. T. E. Levy. Washington: Leicester University Press.

- 2001 *What Did the Biblical Writers Know & When Did They Know It?* Grand Rapids: Eerdmans.
- 2003 Chronology of the Southern Levant. Pp. 82-87 in *Near Eastern Archaeology: A Reader*, ed. S. Richard. Winona Lake: Eisenbrauns.
- Dodson, A.
2001 *The Hieroglyphs of Ancient Egypt*. London: New Holland.
- Donahue, J.
1980 Preliminary Report of the 1979 Expedition to the Dead Sea Plain: Geology. *Bulletin of the American Schools of Oriental Research* 240: 47-52.
- 1984 Geologic Reconstruction of Numeira. *Bulletin of the American Schools of Oriental Research* 255: 83-88.
- 2003 Geology and Geomorphology. Pp. 18-55 in *Bab edh-Dhra': Excavations at the Town Site (1975-1981)*. Reports of the Expedition to the Dead Sea Plain, Jordan, Vol. 2, eds. W. E. Rast and R. T. Schaub. Winona Lake, IN: Eisenbrauns.
- Doumet-Serhal, C.
2009 The Northern Levant at the End of the Early Bronze Age: The Evidence from Sidon. Pp. 21-33 in *The Levant in Transition*. The Palestine Exploration Fund Annual 9, ed. P. J. Parr. Leeds: Maney.
- Ehrich, R. W.
1992 Introduction. Pp. vii-x in *Chronologies in Old World Archaeology*, Vol. 1, 3rd ed., ed. R. W. Ehrich. Chicago: University of Chicago Press.
- Eriksson, K. O.
2003 A Preliminary Synthesis of Recent Chronological Observations on the Relations Between Cyprus and Other Eastern Mediterranean Societies During the Late Middle Bronze–Late Bronze II Periods. Pp. 411-29 in *The Synchronisation of Civilisations in the Eastern Mediterranean in the Second Millennium B.C. II: Proceedings of the SCIEM 2000–EuroConference, Haindorf, 2nd of May–7th of May 2001*, ed. M. Bietak. Vienna, Austria: Österreichischen Akademie der Wissenschaften.
- Esse, D. L.
1991 *Subsistence, Trade, and Social Change in Early Bronze Age Palestine*. Studies in Ancient Oriental Civilization, no. 50. Chicago: Oriental Institute of the University of Chicago.

- Fairman, H. W.
 1939 Preliminary Report on the Excavations at 'Amrah West, Anglo-Egyptian Sudan, 1938-9. *Journal of Egyptian Archaeology* 25: 139-44.
- Falconer, S. E., Fall, P. L., Metzger, M. C., and Lines, L.
 2004 Bronze Age Rural Economic Transitions in the Jordan Valley. *Annual of the American Schools of Oriental Research* 58: 1-17.
- Finkelstein, I.
 1996 Ethnicity and Origin of the Iron I Settlers in the Highlands of Canaan. *Biblical Archaeologist* 59 no. 4: 198-212.
 2005a A Low Chronology Update. Pp. 31-42 in *The Bible and Radiocarbon Dating: Archaeology, Text and Science*, eds. T. E. Levy and T. F. G. Higham. London: Equinox.
 2005b Khirbet en-Nahas, Edom and Biblical History. *Tel Aviv* 32: 119-25.
- Finkelstein, I., and Piasezky, E.
 2003 Comment on "¹⁴C Dates from Tel Rehov: Iron-Age Chronology, Pharaohs, and Hebrew Kings." *Science* 302: 568b.
 2008 Radiocarbon and the History of Copper Production at Khirbet en-Nahas. *Tel Aviv* 35: 82-95.
- Finkelstein, I., and Singer-Avitz, L.
 2008 The Pottery of Edom: A Correction. *Antiquo Oriente* 6: 13-24.
- Finnegan, M.
 1976 Faunal Remains from Bab edh-Dhra', 1975. Pp. 51-54 in *Preliminary Excavation Reports; Bab edh-Dhra', Sardis, Meiron, Tel el-Hesi, Carthage (Punic)*. Annual of the American Schools of Oriental Research, Vol. 43, ed. D. N. Freedman. Cambridge, MA: American Schools of Oriental Research.
- Firneis, M. G.
 2000 Heliacal Sirius-Dates and First Lunar Crescent Dates Depending on Geographical Latitude for the Use in Absolute Chronology. Pp. 58-9 in *The Synchronisation of Civilisations in the Eastern Mediterranean in the Second Millennium B.C.: Proceedings of an International Symposium at Schloß Haindorf, 15th-17th of November 1996 and at the Austrian Academy, Vienna, 11th-12th of May 1998*. Contributions to the Chronology of the Eastern Mediterranean, Vol. 1, ed. M. Bietak. Vienna, Austria: Österreichischen Akademie der Wissenschaften.

- Fischer, P. M.
 2000 The Early Bronze Age at Tell Abu al-Kharaz, Jordan Valley: A Study of Pottery Typology and Provenance, Radiocarbon Dates, and the Synchronization of Palestine and Egypt During Dynasty 0-2. Pp. 201-32 in *Ceramics and Change in the Early Bronze Age of the Southern Levant*. Levantine Archaeology; 2, eds. G. Philip and D. Baird. Sheffield: Sheffield Academic Press.
- Fischer, P. M.
 2001 White Slip I and II from Tell Abu al-Kharaz, Jordan Valley: Pottery Synchronism and Dating. Pp. 161-70 in *The White Slip Ware of Late Bronze Cyprus: Proceedings of an International Conference Organized by the Anastasios G. Leventis Foundation, Nicosia, in Honour of Malcolm Viennaer, Nicosia, 29th-30th October 1998*. Contributions to the Chronology of the Eastern Mediterranean, Vol. 2, ed. V. Karageorghis. Vienna: Österreichischen Akademie der Wissenschaften.
- 2003 The Preliminary Chronology of Tel el-'Ajjul: Results of the Renewed Excavations in 1999 and 2000. Pp. 263-94 in *The Synchronisation of Civilisations in the Eastern Mediterranean in the Second Millennium B.C. II: Proceedings of the SCIEM 2000–EuroConference, Haindorf, 2nd of May–7th of May 2001*, ed. M. Bietak. Vienna, Austria: Österreichischen Akademie der Wissenschaften.
- 2008 Tell Abu al-Kharaz: A Bead in the Jordan Valley. *Near Eastern Archaeology* 71 no. 4: 196-213.
- Fleming, D. E.
 2004 Genesis in History and Tradition: The Syrian Background of Israel's Ancestor, Reprise. Pp. 193-232 in *The Future of Biblical Archaeology: Reassessing Methodologies and Assumptions*, eds. J. K. Hoffmeier and A. R. Millard. Grand Rapids: Eerdmans.
- Freedman, D. N.
 1978 The Real Story of the Ebla Tablets: Ebla and the Cities of the Plain. *Biblical Archaeologist* 41 no. 4: 143-64.
- 1980 Editorial. *Bulletin of the American Schools of Oriental Research* 237: 1-4.
- Fröhlich, B., and Ortner, D. J.
 1982 Excavations of the Early Bronze Cemetery at Bab edh-Dhra Jordan, 1981: A Preliminary Report. *Annual of the Department of Antiquities of Jordan* 26: 249-67.

- Frumkin, A., and Elitzur, Y.
 2001 The Rise and Fall of the Dead Sea. *Biblical Archaeology Review* 27 no. 6: 42-50.
- Galil, G.
 1996 *The Chronology of the Kings of Israel & Judah*. Studies in the History and Culture of the Ancient Near East. New York: E.J. Brill.
- Gardiner, A.
 1917 The Tomb of a Much-Travelled Theban Official. *Journal of Egyptian Archaeology* 4: 28-38.
 1966 *Egypt of the Pharaohs*. New York: Oxford University Press.
- Garfinkel, Y., Carmi, I., and Vogel, J. C.
 1987 Dating of Horsebean and Lentil Seeds from the Pre-Pottery Neolithic B Village of Yiftah'el. *Israel Exploration Journal* 37 no. 1: 40-42.
- Gasche, H., Armstrong, J. A., Cole, S. W., and Gurdzadyan, V. G.
 1998 *Dating the Fall of Babylon: A Reappraisal of Second-Millennium Chronology*. Mesopotamian History and Environment. Chicago: Oriental Institute of the University of Chicago.
- Gerstenblith, P.
 1980 A Reassessment of the Beginning of the Middle Bronze Age in Syria-Palestine. *Bulletin of the American Schools of Oriental Research* 237: 65-84.
 1983 *The Levant at the Beginning of the Middle Bronze Age*. Winona Lake: American Schools of Oriental Research.
- Gilboa, A., Jull, A. J. T., Sharon, I., and Boaretto, E.
 2009 Notes on Iron IIA ¹⁴C Dates from Tell el-Qudeirat (Kadesh Barnea). *Tel Aviv* 36: 82-94.
- Giveon, R.
 1981 Three Fragments from Egyptian Geographical Lists. *Eretz Israel* 15: 137-9.
- Glueck, N.
 1937 An Aerial Reconnaissance in Southern Jordan. *Bulletin of the American Schools of Oriental Research* 67: 19-26.

- Gophna, R.
 1992 The Intermediate Bronze Age. Pp. 126-58 in *The Archaeology of Ancient Israel*, ed. A. Ben-Tor, from R. Greenberg. New Haven: Yale University Press.
- 2009 A Short-Lived Settlement System and a Lengthy Period: The Intermediate Bronze Age ('EB IV') on the Coastal Plain of Israel. Pp. 34-7 in *The Levant in Transition*. The Palestine Exploration Fund Annual 9, ed. P. J. Parr. Leeds: Maney.
- Gordon, C. H.
 1953 *Introduction to Old Testament Times*. Ventnor, NJ: Ventnor Publishers.
- Görg, M.
 2001 Israel in Hieroglyphen. *Biblische Notizen* 106: 21-27.
- Gorsdorf, J., Dreyer, G., and Hartung, U.
 1998 New ¹⁴C Dating of the Archaic Royal Necropolis Umm el-Qaab at Abydos (Egypt). *Radiocarbon* 40 no. 2: 641-47.
- Gove, H. E.
 1992 The History of AMS, its Advantages Over Decay Counting: Applications and Prospects. Pp. 214-29 in *Radiocarbon After Four Decades: An Interdisciplinary Perspective*, eds. R. E. Taylor, A. Long, and R. S. Kra. New York: Springer-Verlag.
- Grove, G.
 1884 Sodom. Pp. 641-2 in *A Dictionary of the Bible*, ed. W. Smith. Philadelphia: John C Winston.
- Gruenthaner, M. J.
 1942 The Date of Abraham. *Catholic Biblical Quarterly* 4: 360-63.
- 1943 The Date of Abraham, II. *Catholic Biblical Quarterly* 5: 85-87.
- Haas, H., Devine, J., Wenke, R., Lehner, M., Wolfli, W., and Bonani, G.
 1987 Radiocarbon Chronology and the Historical Calendar in Egypt. Pp. 585-606 in *Chronologies in the Near East: Relative Chronologies and Absolute Chronology 16,000-4,000 B.P.: C.N.R.S International Symposium, Lyon (France), 24-28 November 1986*, Vol. 2, ed. O. Aurenche. Oxford, England: B.A.R.
- Haas, H., and Doubrava, M. R.
 1998 Calibration Technique for ¹⁴C Data Clusters: Fitting Relative Chronologies Onto Absolute Time Scales. *Radiocarbon* 40: 561-69.

- Hadjisavvas, S.
 2007 The Public Face of the Absolute Chronology for Cypriot Prehistory. Pp. 547-9 in *The Synchronisation of Civilisations in the Eastern Mediterranean in the Second Millennium B.C. III: Proceedings of the SCIEM 2000–2nd EuroConference, Vienna, 28th of May–1st of June 2003*. Contributions to the Chronology of the Eastern Mediterranean, Vol. 9, eds. M. Bietak and E. Czerny. Vienna, Austria: Österreichischen Akademie der Wissenschaften.
- Hallo, W. W., and Simpson, W. K.
 1971 *The Ancient Near East: A History*. New York: Harcourt Brace Jovanovich.
- Hallote, R. S.
 2002 Real and Ideal Identities in Middle Bronze Age Tombs. *Near Eastern Archaeology* 65 no. 2: 105-11.
- Halpern, B.
 2005 David Did It, Others Did Not. Pp. 422-38 in *The Bible and Radiocarbon Dating: Archaeology, Text and Science*, eds. T. E. Levy and T. F. G. Higham. London: Equinox.
- Hankey, V.
 1987 The Chronology of the Aegean Late Bronze Age. Pp. 39-59 in *High, Middle or Low? Acts of an International Colloquium on Absolute Chronology Held at the University of Göthenburge 20th-22nd August 1987: Part 2*, ed. P. Åström. Göthenburg: Åström.
- Harkness, D. D.
 1983 High-Precision C14 Calibration: A Reconnaissance of the Advantages and Potential Dangers. Pp. 25-36 in *Archaeology, Dendrochronology, and the Radiocarbon Calibration Curve*, ed. B. S. Ottaway. Edinburgh: University of Edinburgh.
- Harlan, J. R.
 1982 The Garden of the Lord: A Plausible Reconstruction of Natural Resources of Southern Jordan in Early Bronze Age. *Paléorient* no. 8: 71-78.
- 2003 Natural Resources of the Bab edh-Dhra Region. Pp. 56-61 in *Bab edh-Dhra': Excavations at the Town Site (1975-1981)*. Reports of the Expedition to the Dead Sea Plain, Jordan, Vol. 2, eds. W. E. Rast and R. T. Schaub. Winona Lake, IN: Eisenbrauns.

- Harland, J. P.
1961 Sodom and Gomorrah. Pp. 41-75 in *The Biblical Archaeologist Reader*, eds. D. N. Freedman and G. E. Wright. Garden City, NY: Doubleday.
- Harris, R. L.
1975 Genealogy. Pp. 673-5 in *The Zondervan Pictorial Encyclopedia of the Bible*, Vol. 2, ed. M. C. Tenney. Grand Rapids: Zondervan.
- Harrison, T. P.
2000 The Early Bronze III Ceramic Horizon for Highland Central Jordan. Pp. 347-64 in *Ceramics and Change in the Early Bronze Age of the Southern Levant*. Levantine Archaeology; 2, eds. G. Philip and D. Baird. Sheffield: Sheffield Academic Press.
- Hasel, M. G.
1994 Israel in the Merneptah Stela. *Bulletin of the American Schools of Oriental Research* 296: 45-61.
- Hassan, F. A.
1980 Radiocarbon Chronology of Archaic Egypt. *Journal of Near Eastern Studies* 39 no. 3: 203-07.
- Hassler, A., and Höflmayer, F.
2008 Mostagedda 1874 and Gurob 23: Notes on Some Recent Radiocarbon Dates and Their Importance for Egyptian Archaeology and Chronology. Pp. 145-55 in *Egypt and the Levant 18*, ed. M. Bietak. Vienna: Österreichische Akademie der Wissenschaften.
- Hawkins, R. K.
2007 Propositions for Evangelical Acceptance of a Late-Date Exodus-Conquest: Biblical Data and the Royal Scarabs from Mt. Ebal. *Journal of the Evangelical Theological Society* 50: 249-58.
- Helms, S.
1989 An EB IV Pottery Repertoire at Amman, Jordan. *Bulletin of the American Schools of Oriental Research* 273: 17-36.
- Hendrix, R. E., Drey, P. R., and Storfjell, J. B.
1996 *Ancient Pottery of Transjordan*. Berrien Springs, MI: Institute of Archaeology/Horn Archaeological Museum, Andrews University.
- Hennessy, J. B.
1967 *The Foreign Relations of Palestine During the Early Bronze Age*. Colt Archaeological Institute Publications. London: Quaritch.

- Henry, D. O.
1992 The Impact of Radiocarbon Dating on Near Eastern Prehistory. Pp. 324-34 in *Radiocarbon After Four Decades: An Interdisciplinary Perspective*, eds. R. E. Taylor, A. Long, and R. S. Kra. New York: Springer-Verlag.
- Herr, L.
1997 Periodization. Pp. 267-73 in *The Oxford Encyclopedia of Archaeology in the Near East*, Vol. 4, ed. E. M. Meyers. New York: Oxford University Press.
- Hess, R. S.
2004 Multiple-Month Ritual Calendars in the West Semitic World: Emar 446 and Leviticus 23. Pp. 233-53 in *The Future of Biblical Archaeology: Reassessing Methodologies and Assumptions*, eds. J. K. Hoffmeier and A. R. Millard. Grand Rapids: Eerdmans.
- Higham, T. F. G., van der Plicht, J., Ramsey, C. B., Bruins, H. J., Robinson, M., and Levy, T. E.
2005 Radiocarbon Dating of the Kirbat en-Nahas Site (Jordan) and Bayesian Modeling of the Results. Pp. 164-78 in *The Bible and Radiocarbon Dating: Archaeology, Text and Science*, eds. T. E. Levy and T. F. G. Higham. London: Equinox.
- Hoerth, A. J.
1998 *Archaeology and the Old Testament*. Grand Rapids: Baker Books.
- Hoffmeier, J. K.
2005 *Ancient Israel in Sinai: The Evidence for the Authenticity of the Wilderness Tradition*. New York: Oxford.
2008 *The Archaeology of the Bible*. Oxford: Lion Hudson.
- Holdorf, P.S.
2010 Comparison of the Early Bronze IV Radiocarbon Results from Khirbat Iskandar and Bâb adh-Dhrâ'. Pp. 267-70 in *Khirbat Iskandar: Final Report on the Early Bronze IV Area C "Gateway" and Cemeteries*, eds. S. Richard, J. C. Long, Jr., P. S. Holdorf, and G. Peterman. Boston: American Schools of Oriental Research.
- Hole, F.
1987 Issues in Near Eastern Chronology. Pp. 559-63 in *Chronologies in the Near East: Relative Chronologies and Absolute Chronology 16,000-4,000 B.P.: C.N.R.S International Symposium, Lyon (France), 24-28 November 1986*, Vol. 2, ed. O. Aurenche. Oxford, England: B.A.R.

- Horn, S. H.
 1953 Jericho in a Topographical List of Ramesses II. *Journal of Near Eastern Studies* 12: 201-03.
- 1957 A Revolution in the Early Chronology of Western Asia. *Ministry* 30 no. 6: 4-8.
- Hornung, E., Krauss, R., and Warburton, D. A.
 2006 Chronological Table for the Dynastic Period. Pp. 490-95 in *Ancient Egyptian Chronology*, eds. E. Hornung, R. Krauss, and D. A. Warburton. Boston: Brill.
- Howard, D. M., Jr.
 1984 Sodom and Gomorrah Revisited. *Journal of the Evangelical Theological Society* 27 no. 4: 385-400.
- Huber, P. J.
 1987 Astronomical Evidence for the Long and against the Middle and Short Chronologies. Pp. 5-17 in *High, Middle or Low? Acts of an International Colloquium on Absolute Chronology Held at the University of Göthenburge 20th-22nd August 1987: Part 1*, ed. P. Åström. Göthenburg: Åström.
- Ilan, D.
 1998 The Dawn of Internationalism—The Middle Bronze Age. Pp. 297-319 in *The Archaeology of Society in the Holy Land*, 2nd ed., ed. T. E. Levy. Washington: Leicester University Press.
- 2002 Mortuary Practices in Early Bronze Age Canaan. *Near Eastern Archaeology* 65 no. 2: 92-104.
- Johnson, M. D.
 1969 *The Purpose of the Biblical Chronologies, with Special Reference to the Setting of the Genealogies of Jesus*. Society of New Testament Studies Monograph Series 8. Cambridge: Cambridge University Press.
- Johnston, J. O. D.
 1973 The Problems of Radiocarbon Dating. *Palestine Exploration Quarterly* 105: 13-26.
- Johnston, R. H., and Schaub, R. T.
 1976 Selected Pottery from Bab edh-Dhra', 1975. Pp. 33-49 in *Preliminary Excavation Reports; Bab edh-Dhra', Sardis, Meiron, Tel el-Hesi, Carthage (Punic)*. Annual of the American Schools of Oriental Research, Vol. 43, ed. D. N. Freedman. Cambridge, MA: American Schools of Oriental Research.

- Jull, A. J. T., Donahue, D. J., Broshi, M., and Tov, E.
 1996 Radiocarbon Dating of Scrolls and Linen Fragments from the Judean Desert. *'Atiqot* 28: 85-91.
- Kaiser, W. C.
 2001 *The Old Testament Documents: Are They Reliable and Relevant?* Downer's Grove, IL: InterVarsity.
- Kantor, H. J.
 1965 The Relative Chronology of Egypt and Its Foreign Correlations Before the Late Bronze Age. Pp. 1-46 in *Chronologies in Old World Archaeology*, ed. R. W. Ehrich. Chicago: University of Chicago.
- 1992 The Relative Chronology of Egypt and Its Foreign Correlations Before the First Intermediate Period. Pp. 3-21 in *Chronologies in Old World Archaeology*, Vol. 1, 3rd ed., ed. R. W. Ehrich. Chicago: University of Chicago.
- Keenan, D. J.
 2002 Why Early-historical Radiocarbon Dates Downwind from the Mediterranean Are Too Early. *Radiocarbon* 44: 225-37.
- Kemp, B.
 1980 Egyptian Radiocarbon Dating: A Reply to James Mellaart. *Antiquity* 54: 25-28.
- Kempinski, A.
 1978 *The Rise of An Urban Culture: The Urbaniation of Palestine in the Early Bronze Age, 3000-2150 B.C.* I.E.S. Studies 4. Jerusalem: Israel Ethnographic Society.
- 1992 The Middle Bronze Age. Pp. 159-210 in *The Archaeology of Ancient Israel*, ed. A. Ben-Tor, from R. Greenberg. New Haven: Yale University Press.
- Kenyon, K. M., Bottéro, J., and Posener, G.
 1971 Syria and Palestine c. 2160-1780 B.C. Pp. 532-94 in *Cambridge Ancient History*, Vol. 1, Part 2, 3rd revised ed. Cambridge: Cambridge University.
- Khouri, R. G.
 2003 Looking for the Cities of the Plain. *Artifax* 18 no. 1: 12-13.
- Kitchen, K. A.
 1986 *The Third Intermediate Period in Egypt (1100-650 BC)*. Warminster, England: Aris & Phillips.

- 1987 The Basics of Egyptian Chronology in Relation to the Bronze Age. Pp. 37-55 in *High, Middle or Low? Acts of an International Colloquium on Absolute Chronology Held at the University of Göthenburge 20th-22nd August 1987: Part 1*, ed. P. Åström. Göthenburg: Åström.
- 1991 The Chronology of Ancient Egypt. *World Archaeology* 23: 201-08.
- 1995 The Patriarchal Age: Myth or History? *Biblical Archaeology Review* 21 no. 2: 48-57, 88-95.
- 2000 Regnal and Genealogical Data of Ancient Egypt. Pp. 39-52 in *The Synchronisation of Civilisations in the Eastern Mediterranean in the Second Millennium B.C.: Proceedings of an International Symposium at Schloß Haindorf, 15th–17th of November 1996 and at the Austrian Academy, Vienna, 11th–12th of May 1998*. Contributions to the Chronology of the Eastern Mediterranean, Vol. 1, ed. M. Bietak. Vienna, Austria: Österreichischen Akademie der Wissenschaften.
- 2003a *On the Reliability of the Old Testament*. Grand Rapids: Eerdmans.
- 2003b *Ramesside Inscriptions, Translated & Annotated Translations. Volume IV: Merenptah & the Late Nineteenth Dynasty*. Malden, MA: Blackwell Publishing.
- 2007 Egyptian and Related Chronologies - Look, no Sciences, no Pots! Pp. 163-71 in *The Synchronisation of Civilisations in the Eastern Mediterranean in the Second Millennium B.C. III: Proceedings of the SCIEM 2000–2nd EuroConference, Vienna, 28th of May–1st of June 2003*. Contributions to the Chronology of the Eastern Mediterranean, Vol. 9, eds. M. Bietak and E. Czerny. Vienna, Austria: Österreichischen Akademie der Wissenschaften.
- Kitchen, K. A., and Mitchell, T. C.
 1980 Chronology of the Old Testament. Pp. 268-77 in *The Illustrated Bible Dictionary*, Vol. 1, ed. J. D. Douglas. Leicester, England: Inter-Varsity Press.
- Krauss, R.
 1978 *Das Ende der Amarnazeit*. Hildesheim: Gerstenberg.
- 2003 Arguments in Favor of a Low Chronology for the Middle and New Kingdom in Egypt. Pp. 175-97 in *The Synchronisation of Civilisations in the Eastern Mediterranean in the Second Millennium B.C. II: Proceedings of the SCIEM 2000–EuroConference, Haindorf, 2nd of May–7th of May 2001*, ed. M. Bietak. Vienna, Austria: Österreichischen Akademie der Wissenschaften.

- 2007 An Egyptian Chronology for Dynasties XIII to XXV. Pp. 173-89 in *The Synchronisation of Civilisations in the Eastern Mediterranean in the Second Millennium B.C. III: Proceedings of the SCIEM 2000–2nd EuroConference, Vienna, 28th of May–1st of June 2003*. Contributions to the Chronology of the Eastern Mediterranean, Vol. 9, eds. M. Bietak and E. Czerny. Vienna, Austria: Österreichischen Akademie der Wissenschaften.
- Krauss, R., and Warburton, D. A.
2006 Conclusions. Pp. 473-89 in *Ancient Egyptian Chronology*, eds. E. Hornung, R. Krauss, and D. A. Warburton. Boston: Brill.
- Kromer, B., and Münnich, K. O.
1992 CO₂ Gas Proportional Counting in Radiocarbon Dating - Review and Perspective. Pp. 184-97 in *Radiocarbon After Four Decades: An Interdisciplinary Perspective*, eds. R. E. Taylor, A. Long, and R. S. Kra. New York: Springer-Verlag.
- Kromer, B., Rhein, M., Bruns, M., Schoch-Fischer, H., Münnich, K. O., Stuiver, M., and Becker, B.
1986 Radiocarbon Calibration Data for the 6th to the 8th Millennia BC. *Radiocarbon* 28 no. 2B: 954-60.
- Kuhrt, A.
1995 *The Ancient Near East c. 3000-330 BC*. Routledge History of the Ancient World. New York: Routledge.
- Kuniholm, P., Kromer, B., Manning, S. W., Newton, M., Latini, C. E., and Bruce, M. J.
1996 Anatolian Tree Rings and the Absolute Chronology of the Eastern Mediterranean, 2220-718 BC. *Nature* 381: 780-83.
- Kuniholm, P., Tarter, S., and Griggs, C.
1993 Appendix 2: Dendrochronological Report. Pp. 179-90 in *Tille Höyük*, Vol. 4, ed. G. Summers. Oxford: Oxbow Books.
- Kutschera, W., and Stadler, P.
2000 ¹⁴C Dating for Absolute Chronology of Eastern Mediterranean Cultures in the Second Millennium BC with Accelerator Mass Spectrometry. Pp. 68-81 in *The Synchronisation of Civilisations in the Eastern Mediterranean in the Second Millennium B.C.: Proceedings of an International Symposium at Schloß Haindorf, 15th–17th of November 1996 and at the Austrian Academy, Vienna, 11th–12th of May 1998*. Contributions to the Chronology of the Eastern Mediterranean, Vol. 1, ed. M. Bietak. Vienna, Austria: Österreichischen Akademie der Wissenschaften.

- Kyle, M. G.
1928 *Explorations at Sodom*. New York: Revell.
- Kyle, M. G., and Albright, W. F.
1924 Results of the Archaeological Survey of the Ghor in Search for the Cities of the Plain. *Bibliotheca Sacra* 81: 276-91.
- Lapp, N.
1989 Cylinder Seals and Impressions of the Third Millennium B.C. from the Dead Sea Plain. *Bulletin of the American Schools of Oriental Research* 273: 1-15.

1994 Who is This That Comes from Edom? Pp. 216-29 in *Scripture and Other Artifacts: Essays on the Bible and Archaeology in Honor of Philip J. King*, eds. M. D. Coogan, J. C. Exum, and L. E. Stager. Louisville, KY: Westminster John Knox.

2003 Cylinder Seals, Impressions, and Incised Sherds. Pp. 522-65 in *Bab edh-Dhra': Excavations at the Town Site (1975-1981)*. Reports of the Expedition to the Dead Sea Plain, Jordan, Vol. 1, eds. W. E. Rast and R. T. Schaub. Winona Lake, IN: Eisenbrauns.
- Lapp, P. W.
1966a Bab edh-Dhra'. *Revue Biblique*: 556-61.

1966b The Cemetery at Bab edh-Dhra', Jordan. *Archaeology* 19: 104-11.

1968 Bab edh-Dhra' Tomb A 76 and Early Bronze I in Palestine. *Bulletin of the American Schools of Oriental Research* 189: 12-41.

1975 *The Tale of the Tell*. Pittsburgh Theological Monograph Series No. 5. Pittsburgh: Pickwick Press.
- Lasken, J.
1992 The Radiocarbon Evidence from Thera: An Alternative Interpretation. *Journal of the Ancient Chronology Forum* 5: 68-78.
- Lawrence, P.
2006 *The IVP Atlas of Bible History*. Downers Grove: InterVarsity.
- Leclant, J.
1965 *Les fouilles de Soleb (Nubie soudanaise): Quelques remarques sur les écussons des peuples envoûtés de la salle hypostyle du secteur IV*. Nachrichten der akademie der wissenschaften in Göttingen. Göttingen: Vandenhoeck & Ruprecht.

- Levy, T. E., Adams, R. B., Najjar, M., Hauptmann, A., Anderson, J. D., Brandl, B.,
Robinson, M. A., and Higham, T. F. G.
2004 Reassessing the Chronology of Biblical Edom: New Excavations and
14C Dates from Khirbat en-Nahas (Jordan). *Antiquity* 78: 856-79.
- Levy, T. E., and Najjar, M.
2006 Some Thoughts on Khirbet en-Nahas, Edom, Biblical History and
Anthropology--A Response to Israel Finklestein. *Tel Aviv* 33: 3-17.
- Levy, T. E., Najjar, M., and Higham, T. F. G.
2007 Iron Age Complex Societies, Radiocarbon Dates and Edom: Working
with the Data and Debates. *Antiquo Oriente* 5: 13-34.
- Linick, T. W., Long, A., Damon, P. E., and Ferguson, C. W.
1986 High-Precision Radiocarbon Dating of Bristlecone Pine from 6554 to
5350 BC. *Radiocarbon* 28 no. 2B: 943-53.
- Long, J. C., Jr.
2003 Theory in Archaeology: Culture Change at the End of the Early Bronze
Age. Pp. 308-18 in *Near Eastern Archaeology: A Reader*, ed. S.
Richard. Winona Lake: Eisenbrauns.
- MacDonald, B.
1995 EB IV Tombs at Khirbet Khanazir: Types, Construction, and Relation
to other EB IV Tombs in Syria-Palestine. *Studies in the History and
Archaeology of Jordan* 5: 129-34.
- Maier, A. M.
2004 Review of Karageorghis, V., ed., "The White Slip Ware of Late Bronze
Age Cyprus." *Israel Exploration Journal* 54 no. 1: 116-19.
- Mallon, A.
1924 Flint Implements and Megalithic Monuments. *Bibliotheca Sacra* 81:
271-75.
- Mallon, P.
1932 The Five Cities of the Plain (Genesis XIV). *Palestine Exploration
Quarterly*: 52-56.
- Manning, S. W.
1995 *The Absolute Chronology of the Aegean Early Bronze Age:
Archaeology, Radiocarbon, and History*. Monographs in Mediterranean
Archaeology; 1. Sheffield: Sheffield Academic Press.

- 2006 Radiocarbon Dating and Egyptian Chronology. Pp. 327-55 in *Ancient Egyptian Chronology*, eds. E. Hornung, R. Krauss, and D. A. Warburton. Boston: Brill.
- 2007 Clarifying the 'High' v. 'Low' Aegean/Cypriote Chronology for the Mid Second Millennium BC: Assessing the Evidence, Interpretive Frameworks, and Current State of the Debate. Pp. 101-37 in *The Synchronisation of Civilisations in the Eastern Mediterranean in the Second Millennium B.C. III: Proceedings of the SCIEM 2000–2nd EuroConference, Vienna, 28th of May–1st of June 2003*. Contributions to the Chronology of the Eastern Mediterranean, Vol. 9, eds. M. Bietak and E. Czerny. Vienna, Austria: Österreichischen Akademie der Wissenschaften.
- Marchetti, N.
2003 A Century of Excavations on the Spring Hill at Tell Es-Sultan, Ancient Jericho: A Reconstruction of Its Stratigraphy. Pp. 295-321 in *The Synchronisation of Civilisations in the Eastern Mediterranean in the Second Millennium B.C. II: Proceedings of the SCIEM 2000–EuroConference, Haindorf, 2nd of May–7th of May 2001*, ed. M. Bietak. Vienna, Austria: Österreichischen Akademie der Wissenschaften.
- Marcus, E. S., Porath, Y., and Paley, S. M.
2008 The Early Bronze Age IIA Phases at Tel Ifshar and the External Relations. Pp. 222-44 in *Egypt and the Levant 18*, ed. M. Bietak. Vienna: Österreichische Akademie der Wissenschaften.
- Matthiae, P.
1989 The Destruction of Ebla Royal Palace: Interconnections between Syria, Mesopotamia and Egypt in the Late EB IVA. Pp. 163-9 in *High, Middle or Low? Acts of an International Colloquium on Absolute Chronology Held at the University of Göthenburge 20th-22nd August 1987: Part 3*, ed. P. Åström. Göthenburg: Åström.
- 2000 Studies in the Relative and Absolute Chronology of Syria in the IInd Millennium B.C. Pp. 136-9 in *The Synchronisation of Civilisations in the Eastern Mediterranean in the Second Millennium B.C.: Proceedings of an International Symposium at Schloß Haindorf, 15th–17th of November 1996 and at the Austrian Academy, Vienna, 11th–12th of May 1998*. Contributions to the Chronology of the Eastern Mediterranean, Vol. 1, ed. M. Bietak. Vienna, Austria: Österreichischen Akademie der Wissenschaften.
- Mazar, A.
1990 *Archaeology of the Land of the Bible*. New York: Doubleday.

- 2001a On the Significance of the Early Bronze III Granary Building at Beit Yerah. Pp. 447-64 in *Studies in the Archaeology of Israel and Neighboring Lands in Memory of Douglas L. Esse*. Studies in Ancient Oriental Civilization, No. 59, ed. S. R. Wolff. Chicago: The Oriental Institute of the University of Chicago.
- 2001b Radiocarbon Dates from Iron Age Strata at Tel Beth Shean and Tel Rehov. *Radiocarbon* 43 no. 2: 1333-42.
- 2003 Beth Shean in the Second Millennium B.C.E.: From Canaanite Town to Egyptian Stronghold. Pp. 323-39 in *The Synchronisation of Civilisations in the Eastern Mediterranean in the Second Millennium B.C. II: Proceedings of the SCIEM 2000–EuroConference, Haindorf, 2nd of May–7th of May 2001*, ed. M. Bietak. Vienna, Austria: Österreichischen Akademie der Wissenschaften.
- 2005 The Debate over the Chronology of the Iron Age in the Southern Levant: Its History, the Current Situation, and a Suggested Resolution. Pp. 15-30 in *The Bible and Radiocarbon Dating: Archaeology, Text and Science*, eds. T. E. Levy and T. F. G. Higham. London: Equinox.
- 2007 Myc IIIc in the Land Israel: Its Distribution, Date and Significance. Pp. 571-82 in *The Synchronisation of Civilisations in the Eastern Mediterranean in the Second Millennium B.C. III: Proceedings of the SCIEM 2000–2nd EuroConference, Vienna, 28th of May–1st of June 2003*. Contributions to the Chronology of the Eastern Mediterranean, Vol. 9, eds. M. Bietak and E. Czerny. Vienna, Austria: Österreichischen Akademie der Wissenschaften.
- Mazzoni, S.
1985 Elements of the Ceramic Culture of Early Syrian Ebla in Comparison with Syro-Palestinian EB IV. *Bulletin of the American Schools of Oriental Research* 257: 1-18.
- McCormac, F. G., Hogg, A. G., Higham, T. F. G., Baillie, M. G. L., Palmer, J. G., Xiong, L., Pilcher, J. R., Brown, D., and Hoper, S. T.
1998 Variations of Radiocarbon in Tree Rings: Southern Hemisphere Offset Preliminary Results. *Radiocarbon* 40 no. 3: 1153-59.
- McCreery, D.
2003 The Paleoethnobotany of Bab Edh-Dhra'. Pp. 449-63 in *Bab edh-Dhra': Excavations at the Town Site (1975-1981)*. Reports of the Expedition to the Dead Sea Plain, Jordan, Vol. 2, eds. W. E. Rast and R. T. Schaub. Winona Lake, IN: Eisenbrauns.

- McFall, L.
 1989 Did Thiele Overlook Hezekiah's Coregency? *Bibliotheca Sacra* 146: 393-404.
- 1992 Some Missing Coregencies in Thiele's Chronology. *Andrews University Seminary Studies* 30 no. 1: 35-58.
- Mellaart, J.
 1966 *The Chalcolithic and Early Bronze Ages in the Near East and Anatolia*. Beirut: Khayats.
- 1980 Egyptian and Near Eastern Chronology: A Dilema? *Antiquity* 53: 6-18.
- Merrill, E. H.
 1980 Fixed Dates in Patriarchal Chronology. *Bibliotheca Sacra* 137 no. 547: 241-51.
- Merrillees, R. S.
 1992 The Absolute Chronology of the Bronze Age in Cyprus: A Revision. *Bulletin of the American Schools of Oriental Research* 288: 47-52.
- Meyers, E. M.
 1997 Appendix 2: Chronologies. Pp. 411-13 in *The Oxford Encyclopedia of Archaeology in the Near East*, ed. E. M. Meyers. New York: Oxford University Press.
- Miller, J. M.
 1977 The Patriarchs and Extra-Biblical Sources: A Response. *Journal for the Study of the Old Testament* 2: 62-67.
- Milojčić, V. V.
 1965 Die Tontafeln von Tărtăria (Siebenbürgen) und die absolute Chronologie des mitteleuropäischen Neolithikums. *Germania* 43: 261-68.
- Montet, P.
 1958 *Everyday Life in Egypt*, from A. R. Maxwell-Hyslop and M. S. Drower. London: Edward Arnold.
- Morandi Bonacossi, D.
 2009 Tell Mishrifeh and Its Region During the EBA IV and the EBA-MBA Transition: A First Assessment. Pp. 56-68 in *The Levant in Transition*. The Palestine Exploration Fund Annual 9, ed. P. J. Parr. Leeds: Maney.
- Mulder, M. J.
 1992 Sodom and Gomorrah. Pp. 99-103 in *The Anchor Bible Dictionary*, Vol. 6, ed. D. N. Freedman. New York: Doubleday.

- Murnane, W. J.
 1995 The History of Ancient Egypt. Pp. 691-714 in *Civilizations of the Ancient Near East*, Vol. 2, ed. J. M. Sasson. New York.
- Neev, D., and Emery, K. O.
 1995 *The Destruction of Sodom, Gomorrah, and Jericho: Geological, Climatological, and Archaeological Background*. New York: Oxford University Press.
- Newgrosh, B.
 1990 Still at the Crossroads: A Response to Mike Baillie. *Journal of the Ancient Chronology Forum* 3: 37-41.
 1992 Living with Radiocarbon Dates: A Response to Mike Baillie. *Journal of the Ancient Chronology Forum* no. 5: 74-75.
- Nigro, L.
 2003 The Smith and the King of Ebla. Tell el-Yahudiyeh Ware, Metallic Wares and the Ceramic Chronology of Middle Bronze Syria. Pp. 345-63 in *The Synchronisation of Civilisations in the Eastern Mediterranean in the Second Millennium B.C. II: Proceedings of the SCIEM 2000–EuroConference, Haindorf, 2nd of May–7th of May 2001*, ed. M. Bietak. Vienna, Austria: Österreichischen Akademie der Wissenschaften.
- Nissen, H. J.
 1987 The Chronology of the Proto- and Early Historic Periods in Mesopotamia and Susiana. Pp. 607-14 in *Chronologies in the Near East: Relative Chronologies and Absolute Chronology 16,000-4,000 B.P.: C.N.R.S International Symposium, Lyon (France), 24-28 November 1986*, Vol. 2, ed. O. Aurenche. Oxford, England: B.A.R.
- Novák, M.
 2007 Mittani Empire and the Question of Absolute Chronology: Some Archaeological Considerations. Pp. 389-401 in *The Synchronisation of Civilisations in the Eastern Mediterranean in the Second Millennium B.C. III: Proceedings of the SCIEM 2000–2nd EuroConference, Vienna, 28th of May–1st of June 2003*. Contributions to the Chronology of the Eastern Mediterranean, Vol. 9, eds. M. Bietak and E. Czerny. Vienna, Austria: Österreichischen Akademie der Wissenschaften.
- Oakes, L., and Gahlin, L.
 2002 *Ancient Egypt*. New York: Hermes House.
- Oates, J.
 1979 *Babylon*. London: Thames and Hudson.

- Olávarri, E.
1969 Fouilles a 'Arô'er sur l'Arnon: Les Niveaux du Bronze Intermédiaire. *Revue Biblique* 76 no. 2: 230-59.
- Olavarri-Goicoechea, E.
1993 Aroer (in Moab). Pp. 92-3 in *The New Encyclopedia of Archaeological Excavations in the Holy Land*, Vol. 1, ed. E. Stern. New York: Simon & Schuster.
- Oren, E.
1973 The Early Bronze IV Period in Northern Palestine and Its Cultural and Chronological Setting. *Bulletin of the American Schools of Oriental Research* 210: 20-36.
- Ottaway, B. S.
1983 Introduction. Pp. 1-4 in *Archaeology, Dendrochronology, and the Radiocarbon Calibration Curve*, ed. B. S. Ottaway. Edinburgh: University of Edinburgh.
- Palumbo, G.
1990 *The Early Bronze Age IV in the Southern Levant: Settlement Patterns, Economy, and Material Culture of a 'Dark Age'*. Contributi e materiali di archeologia orientale. Roma: Università degli studi di Roma La Sapienza.
- Pearce, N. J. G., Westgate, J. A., Preece, S. J., Eastwood, W. J., Perkins, W. T., and Hart, J. S.
2007 Reinterpretation of Greenland Ice-Core Data Recognises the Presence of the Late Holocene Aniakchak Tephra (Alaska), not the Minoan Tephra (Santorini), at 1645 BC. Pp. 139-47 in *The Synchronisation of Civilisations in the Eastern Mediterranean in the Second Millennium B.C. III: Proceedings of the SCIEM 2000–2nd EuroConference, Vienna, 28th of May–1st of June 2003*. Contributions to the Chronology of the Eastern Mediterranean, Vol. 9, eds. M. Bietak and E. Czerny. Vienna, Austria: Österreichischen Akademie der Wissenschaften.
- Pearson, G. W., Pilcher, J. R., Baillie, M. G. L., Corbett, D. M., and Qua, F.
1986 High-Precision ¹⁴C Measurements of Irish Oaks to Show the Natural ¹⁴C Variations from AD 1840 to 5210 BC. *Radiocarbon* 28 no. 2B: 911-34.
- Pearson, G. W., and Stuiver, M.
1986 High-Precision Calibration of the Radiocarbon Time Scale, 500-2500 BC. *Radiocarbon* 28 no. 2B: 839-62.
- Petrie, W. F.
1931 *Ancient Gaza, I*. London: British School of Archaeology in Egypt.

- Petrovich, D.
2008 The Dating of Hazor's Destruction in Joshua 11 By Way of Biblical, Archaeological, and Epigraphical Evidence. *Journal of the Evangelical Theological Society* 51 no. 3: 489-512.
- Philip, G., and Baird, D.
2000 Early Bronze Age Ceramics in the Southern Levant: An Overview. Pp. 3-29 in *Ceramics and Change in the Early Bronze Age of the Southern Levant*. Levantine Archaeology; 2, eds. G. Philip and D. Baird. Sheffield: Sheffield Academic Press.
- Pinnock, F.
2009 EB IVB-MBI in Northern Syria: Crisis and Change of a Mature Urban Civilisation. Pp. 69-79 in *The Levant in Transition*. The Palestine Exploration Fund Annual 9, ed. P. J. Parr. Leeds: Maney.
- Polach, H. A.
1992 Four Decades of Progress in ¹⁴C Dating by Liquid Scintillation Counting and Spectrometry. Pp. 198-213 in *Radiocarbon After Four Decades: An Interdisciplinary Perspective*, eds. R. E. Taylor, A. Long, and R. S. Kra. New York: Springer-Verlag.
- Politis, K.
2004 Where Lot's Daughters Seduced Their Father. *Biblical Archaeology Review* 30 no. 1: 20-31, 64.
- Porada, E., Hansen, D. P., and Dunham, S.
1992 The Relative Chronology of Egypt and Its Foreign Correlations Before the First Intermediate Period. Pp. 77-121 in *Chronologies in Old World Archaeology*, Vol. 1, 3rd ed., ed. R. W. Ehrich. Chicago: University of Chicago.
- Porter, R. M.
2005 Thera and the End of the Middle Bronze Age. *Journal of the Ancient Chronology Forum* 10: 43-7.
- Posener, G.
1971 Syria and Palestine, c. 2160-1780 B.C. Pp. 532-58 in *Cambridge Ancient History*, Vol. 1, 3rd ed. Cambridge: Cambridge University Press.
- Prag, K.
2009 The Late Third Millennium in the Levant: A Reappraisal of the North-South Divide. Pp. 80-9 in *The Levant in Transition*. The Palestine Exploration Fund Annual 9, ed. P. J. Parr. Leeds: Maney.

- Pritchard, J. B.
1963 *The Bronze Age Cemetery at Gibeon*. Philadelphia: University Museum, University of Pennsylvania.
- Provan, I., Long, V. P., and Longman, T., III
2003 *A Biblical History of Israel*. Louisville: Westminster John Knox.
- Rainey, A. F.
1991 Can You Name the Panel with the Israelites? Rainey's Challenge. *Biblical Archaeology Review* 17 no. 6: 54-61, 91-2.

1999 The Forum. *Archaeology Odyssey* 2 no. 2: 60.

2007 Whence Came the Israelites and Their Language? *Israel Exploration Journal* 57 no. 1: 41-64.
- Ramsey, C. B.
2005 Improving the Resolution of Radiocarbon Dating by Statistical Analysis. Pp. 57-64 in *The Bible and Radiocarbon Dating: Archaeology, Text and Science*, eds. T. E. Levy and T. F. G. Higham. London: Equinox.
- Ramsey, C. B., Dee, M. W., Rowland, J. M., Higham, T. F. G., Harris, S. A., Brock, F., Quiles, A., Wild, E. M., Marcus, E. S., and Shortland, A. J.
2010 Radiocarbon-Based Chronology for Dynastic Egypt. *Science* 328: 1554-57.
- Rasmussen, C.
1989 *Zondervan NIV Atlas of the Bible*. Grand Rapids: Zondervan.
- Rast, W. E.
1980 Palestine in the 3rd Millennium: Evidence for Interconnections. *Scripta Mediterranea* 1: 5-20.

1981 Settlement at Numeira. Pp. 35-44 in *Annual of the American Schools of Oriental Research* 46, eds. W. E. Rast and R. T. Schaub. Cambridge, MA: American Schools of Oriental Research.

1987a Bab edh-Dhra and the Origin of the Sodom Saga. Pp. 185-201 in *Archaeology and Biblical Interpretation: Essays in Memory of D. Glenn Rose*, eds. L. G. Perdue, L. E. Toombs, and G. L. Johnson. Atlanta: John Knox.

1987b Bronze Age Cities Along the Dead Sea. *Archaeology* 40: 42-49.

1992 Bab edh-Dhra'. Pp. 559-61 in *The Anchor Bible Dictionary*, Vol. 1, ed. D. N. Freedman. New York: Doubleday.

- 2001 Early Bronze Age State Formation in the Southeast Dead Sea Plain, Jordan. Pp. 519-54 in *Studies in the Archaeology of Israel and Neighboring Lands in Memory of Douglas L. Esse*. Studies in Ancient Oriental Civilization, No. 59, ed. S. R. Wolff. Chicago: The Oriental Institute of the University of Chicago.
- 2003 Archaeology of the Dead Sea Plain in Jordan. Pp. 319-30 in *Near Eastern Archaeology: A Reader*, ed. S. Richard. Winona Lake: Eisenbrauns.
- Rast, W. E., and Schaub, R. T.
- 1974 Survey of the Southeastern Plain of the Dead Sea, 1973. *Annual of the Department of Antiquities of Jordan* 19: 5-53, 175-85.
- 1976 A Preliminary Report of Excavations at Bab edh-Dhra', 1975. Pp. 1-32 in *Preliminary Excavation Reports; Bab edh-Dhra', Sardis, Meiron, Tel el-Hesi, Carthage (Punic)*. Annual of the American Schools of Oriental Research, Vol. 43, ed. D. N. Freedman. Cambridge, MA: American Schools of Oriental Research.
- 2003a *Bab edh-Dhra': Excavations at the Town Site (1975-1981), Part 1: Text*. Reports of the Expedition to the Dead Sea Plain, Jordan. Winona Lake, IN: Eisenbrauns.
- 2003b *Bab edh-Dhra': Excavations at the Town Site (1975-1981), Part 2: Plates and Appendixes*. Reports of the Expedition to the Dead Sea Plain, Jordan. Winona Lake, IN: Eisenbrauns.
- Rast, W. E., Schaub, R. T., Donahue, J., McCreery, D., and McConaughy, M.
- 1980 Preliminary Report of the 1979 Expedition to the Dead Sea Plain, Jordan. *Bulletin of the American Schools of Oriental Research* 240: 21-61.
- Rast, W. E., and Zeiger, M.
- 1986 *Preliminary Reports of ASOR-Sponsored Excavations, 1980-84*. Winona Lake, IN: Eisenbrauns.
- 1988 *Preliminary Reports of ASOR-Sponsored Excavations, 1982-85*. Baltimore, MD: Johns Hopkins University Press.
- 1990 *Preliminary Reports of ASOR-Sponsored Excavations, 1983-87*. Baltimore, MD: Johns Hopkins University Press.
- 1991 *Preliminary Reports of ASOR-Sponsored Excavations, 1982-89*. Baltimore, MD: Johns Hopkins University Press.

- Rawlinson, G.
1880 *History of Ancient Egypt*. New York: Dodd, Mead & Company.
- Ray, P. J., Jr.
1986 The Duration of the Israelite Sojourn in Egypt. *Andrews University Seminary Studies* 24 no. 3: 231-48.

1997 Problems of Middle and Late Bronze Age Chronology: Toward a Solution. *Near East Archaeological Society Bulletin* 42: 1-13.

2005 Another Look at the Period of the Judges. Pp. 93-104 in *Beyond the Jordan*, ed. G. A. Carnagey, Sr. Eugene, OR: Wipf & Stock.
- Redford, D. B.
1992 *Egypt, Canaan, and Israel in Ancient Times*. Princeton: Princeton University Press.
- Reed, J. K.
2008 Toppling the Timescale, Part III: Madness in the Methods. *Creation Research Society Quarterly* 45: 6-17.
- Reeves, N., and Wilkinson, R. H.
1996 *The Complete Valley of the Kings*. New York: Thames & Hudson.
- Richard, S.
1980 Toward a Consensus of Opinion on the End of the Early Bronze Age in Palestine-Jordan. *Bulletin of the American Schools of Oriental Research* 237: 5-34.

1993 Iskander, Khirbet. Pp. 649-52 in *The New Encyclopedia of Archaeological Excavations in the Holy Land*, Vol. 2, ed. E. Stern. New York: Simon & Schuster.

2003 The Early Bronze Age in the Southern Levant. Pp. 286-302 in *Near Eastern Archaeology: A Reader*, ed. S. Richard. Winona Lake: Eisenbrauns.
- Richard, S., and Long, J. C., Jr.
2009 Khirbet Iskander, Jordan and Early Bronze IV Studies: A View from a Tell. Pp. 90-100 in *The Levant in Transition*. The Palestine Exploration Fund Annual 9, ed. P. J. Parr. Leeds: Maney.

- Richardson, J. B. I., and McCreery, D.
 1976 A Preliminary Report of Excavations at Bab edh-Dhra', 1975. Pp. 55-56 in *Preliminary Excavation Reports; Bab edh-Dhra', Sardis, Meiron, Tel el-Hesi, Carthage (Punic)*. Annual of the American Schools of Oriental Research, Vol. 43, ed. D. N. Freedman. Cambridge, MA: American Schools of Oriental Research.
- Riggs, J. R.
 1971 The Length of Israel's Sojourn in Egypt. *Grace Theological Journal* 12 no. 1: 18-35.
- Roaf, M.
 1996 *Cultural Atlas of Mesopotamia and the Ancient Near East*. New York: Facts on File.
- Roux, G.
 1992 *Ancient Iraq*. New York: Penguin.
- Russmann, E. R.
 2001 *Eternal Egypt*. Los Angeles: University of California Press.
- Rybka, T. W.
 1982 Consequences of Time Dependent Nuclear Decay Indices on Half Lives. *Impact* no. 106.
- Sassmannshausen, L.
 2004 Babylonian Chronology of the 2nd Millennium B.C. Pp. 61-70 in *Mesopotamian Dark Age Revisited: Proceedings of an International Conference of SCIEM 2000, Vienna 8th-9th November 2002*. Contributions to the Chronology of the Eastern Mediterranean, Vol. 6, eds. H. Hunger and R. Pruzsinszky. Vienna, Austria: Österreichischen Akademie der Wissenschaften.
- Sauer, J. A.
 1982 Syro-Palestinian Archeology, History, and Biblical Studies. *Biblical Archaeologist* 45 no. 4: 201-9.
 1994 A New Climatic and Archaeological View of the Early Biblical Traditions. Pp. 366-98 in *Scripture and Other Artifacts: Essays on the Bible and Archaeology in Honor of Philip J. King*, eds. M. D. Coogan, J. C. Exum, and L. E. Stager. Louisville, KY: Westminster John Knox.
- Savage, S. H.
 2001 Towards an AMS Radiocarbon Chronology of Predynastic Egyptian Ceramics. *Radiocarbon* 43 no. 2: 1255-77.

- Schaub, R. T.
 1973 An Early Bronze IV Tomb from Bab edh-Dhra'. *Bulletin of the American Schools of Oriental Research* 210: 2-19.
- 1993 Bab edh-Dhra'. Pp. 130-36 in *The New Encyclopedia of Archaeological Excavations in the Holy Land*, Vol. 1, ed. E. Stern. New York: Simon & Schuster.
- 1997a Bab edh-Dhra'. Pp. 248-51 in *The Oxford Encyclopedia of Archaeology in the Near East*, Vol. 1, ed. E. M. Meyers. New York: Oxford University Press.
- 1997b Southeast Dead Sea Plain. Pp. 62-64 in *The Oxford Encyclopedia of Archaeology in the Near East*, Vol. 5, ed. E. M. Meyers. New York: Oxford University Press.
- 2009 The Southern Ghors and the Kerak Plateau in EB IV. Pp. 101-10 in *The Levant in Transition*. The Palestine Exploration Fund Annual 9, ed. P. J. Parr. Leeds: Maney.
- Schaub, R. T., and Rast, W. E.
 1984 Preliminary Report of the 1981 Expedition to the Dead Sea Plain, Jordan. *Bulletin of the American Schools of Oriental Research* 254: 35-60.
- 1989 *Bab edh-Dhra': Excavations in the Cemetery Directed by Paul W. Lapp (1965-67)*. Reports of the Expedition to the Dead Sea Plain, Jordan. Winona Lake, IN: Eisenbrauns.
- Schick, T.
 1988 Nahal Hemar Cave Cordage, Basketry and Fabrics. *'Atiqot* 18 no. 1988: 31-6.
- Schiestl, R.
 2006 The Statue of an Asiatic Man from Tell el-Dab'a, Egypt. *Ägypten und Levante* 16: 173-85.
- Schneider, T.
 2008 Das Ende der Kurzen Chronologie: Eine Kritische Bilanz der Debate zur Absoluten Datierung des Mittleren Reiches und der Zweiten Swischenzeit. Pp. 275-313 in *Egypt and the Levant 18*, ed. M. Bietak. Vienna: Österreichische Akademie der Wissenschaften.
- Scott, M. E.
 2003 The Fourth International Radiocarbon Intercomparison. *Radiocarbon* 45 no. 2: 135-328.

- Segal, D., and Carmi, I.
 2001 A Series of Radiocarbon Dates from the Late Early Bronze Age I Site at Horvat 'Illin Tahtit. Pp. 551-54 in *Studies in the Archaeology of Israel and Neighboring Lands in Memory of Douglas L. Esse*. Studies in Ancient Oriental Civilization, No. 59, ed. S. R. Wolff. Chicago: The Oriental Institute of the University of Chicago.
- Segal, D., Carmi, I., Gal, Z., Smithline, H., and Shalem, D.
 1998 Dating a Chalcolithic Burial Cave in Peqi'in, Upper Galilee, Israel. *Radiocarbon* 40 no. 2: 707-12.
- Seger, J. D.
 1989 Some Provisional Correlations in EB III Stratigraphy in Southern Palestine. Pp. 117-35 in *L'Urbanisation de la Palestine à l'âge du Bronze ancien : Bilan et perspectives des recherches actuelles : Actes du Colloque d'Emmaüs, 20-24 octobre 1986*. BAR International Series; 527, Vol. 1, ed. P. de Miroschedji. Oxford: B.A.R.
- Selman, M. J.
 1980 Comparative Customs and the Patriarchal Age. Pp. 91-139 in *Essays on the Patriarchal Narratives*, eds. A. R. Millard and D. J. Wiseman. Winona Lake, IN: Eisenbrauns.
- Shanks, H.
 1980 Have Sodom & Gomorrah Been Found? *Biblical Archaeology Review* 6 no. 5: 27-36.
- Sharon, I., Gilboa, A., and Boaretto, E.
 2007 ¹⁴C and the Early Iron Age of Israel—Where Are We Really At? A Commentary on the Tel Rehov Radiometric Dates. Pp. 149-55 in *The Synchronisation of Civilisations in the Eastern Mediterranean in the Second Millennium B.C. III: Proceedings of the SCIEM 2000–2nd EuroConference, Vienna, 28th of May–1st of June 2003*. Contributions to the Chronology of the Eastern Mediterranean, Vol. 9, eds. M. Bietak and E. Czerny. Vienna, Austria: Österreichischen Akademie der Wissenschaften.
- Shaw, I. M. E.
 1985 Egyptian Chronology and the Irish Oak Calibration. *Journal of Near Eastern Studies* 44 no. 4: 295-317.
- Shea, W. S.
 1988 Numeira. *Archaeology and Biblical Research* 1 no. 4: 12-23.
- Silverman, D. P.
 1997 *Ancient Egypt*. New York: Oxford University Press.

- Smith, G. A.
1884 Abraham. Pp. 13-15 in *A Dictionary of the Bible*, ed. G. A. Smith. Philadelphia: John C. Winston.
- Stager, L. E.
1992 The Periodization of Palestine from Neolithic Through Early Bronze Times. Pp. 22-41 in *Chronologies in Old World Archaeology*, Vol. 1, 3rd ed., ed. R. W. Ehrich. Chicago: University of Chicago.
- Steindorff, G., and Seele, K. C.
1957 *When Egypt Ruled the East*. Chicago: University of Chicago Press.
- Steinmann, A. E.
2005 The Mysterious Numbers of the Book of Judges. *Journal of the Evangelical Theological Society* 48 no. 3: 491-500.
- Stern, E.
1993 *The New Encyclopedia of Archaeological Excavations in the Holy Land*. New York: Simon & Schuster.
- Stuiver, M., and Pearson, G. W.
1986 High-Precision Calibration of the Radiocarbon Time Scale, AD 1950-500 BC. *Radiocarbon* 28 no. 2B: 805-38.
- Stuiver, M., and van der Plicht, J.
1998 Editorial Comment. *Radiocarbon* 40 no. 3: xxi-xiv.
- Thiele, E. R.
1983 *The Mysterious Numbers of the Hebrew Kings*. Grand Rapids: Zondervan.
- Thompson, T. L.
1974 *The Historicity of the Patriarchal Narratives: The Quest for the Historical Abraham*. Beihefte zur Zeitschrift für die alttestamentliche Wissenschaft 133. Berlin: de Gruyter.
- Tubb, J. N.
2009 Aliens in the Levant. Pp. 111-17 in *The Levant in Transition*. The Palestine Exploration Fund Annual 9, ed. P. J. Parr. Leeds: Maney.
- Tufnell, O., and Ward, W. A.
1966 Relations Between Byblos, Egypt, and Mesopotamia at the End of the Third Millennium B.C.: A Study of the Montet Jar. *Syria* 43: 165-241.

- van der Plicht, J., and Bruins, H. J.
 2001 Radiocarbon Dating in Near-Eastern Contexts: Confusion and Quality Control. *Radiocarbon* 43 no. 3: 1155-66.
- 2005 Quality Control of Groningen ¹⁴C Results from Tel Rehov. Pp. 256-70 in *The Bible and Radiocarbon Dating: Archaeology, Text and Science*, eds. T. E. Levy and T. F. G. Higham. London: Equinox.
- van der Veen, P., Theis, C., and Görg, M.
 2010 Israel in Canaan (Long) Before Pharaoh Merenptah? A Fresh Look at Berlin Statue Pedastal Relief 21687. *Journal of Ancient Egyptian Interconnections* 2 no. 4: 15-25.
- van Hattem, W. C.
 1981 Once Again: Sodom and Gomorrah. *Biblical Archaeologist* 44 no. 2: 87-92.
- Veenhof, K. R.
 2000 Old Assyrian Chronology. *Akkadica* no. 119-120: 137-50.
- Vogel, J. C., Fuls, A., and Visser, E.
 1986 Radiocarbon Fluctuations During the Third Millennium BC. *Radiocarbon* 28 no. 2B: 935-38.
- Warburton, D. A.
 2002 Eclipses, Venus-Cycles & Chronology. *Akkadica* 123: 108-14.
- Ward, W. A.
 1991 Early Contacts Between Egypt, Canaan, and Sinai: Remarks on the Paper by Amnon Ben-Tor. *Bulletin of the American Schools of Oriental Research* 281: 11-26.
- 1992 The Present Status of Egyptian Chronology. *Bulletin of the American Schools of Oriental Research* 288: 53-66.
- Warner, S. M.
 1977 The Patriarchs and Extra-Biblical History. *Journal for the Study of the Old Testament* 2: 50-61.
- Weinstein, J. M.
 1980 Palestinian Radiocarbon Dating: A Reply to James Mellaart. *Antiquity* 54: 21-24.
- 1984 Radiocarbon Dating in the Southern Levant. *Radiocarbon* 26: 297-366.

- 1988 Radiocarbon Dating. Pp. 337-52 in *Benchmarks in Time and Culture: An Introduction to Palestinian Archaeology. Essays in Honor of Joseph A. Callaway*. Archaeology and Biblical Studies/Society of Biblical Literature; no. 1, eds. J. F. Drinkard, G. L. Mattingly, J. M. Miller, and J. A. Callaway. Atlanta: Scholars Press.
- 1992 The Chronology of Palestine in the Early Second Millennium B.C.E. *Bulletin of the American Schools of Oriental Research* 288: 27-46.
- 2003 A New Set of Radiocarbon Dates from the Town Site. Pp. 638-48 in *Bab edh-Dhra': Excavations at the Town Site (1975-1981)*. Reports of the Expedition to the Dead Sea Plain, Jordan, Vol. 2, eds. W. E. Rast and R. T. Schaub. Winona Lake, IN: Eisenbrauns.
- Wiener, M. H.
- 2001 The White Slip I of Tell el-Dab'a and Thera: Critical Challenges for the Aegean Long Chronology. Pp. 195-202 in *The White Slip Ware of Bronze Age Cyprus: Proceedings of an International Conference Organized by the Anastasios G. Leventis Foundation, Nicosia, in Honour of Malcolm Viennater, Nicosia, 29th-30th October 1998*. Contributions to the Chronology of the Eastern Mediterranean, Vol. 2, ed. V. Karageorghis. Vienna, Austria: Österreichischen Akademie der Wissenschaften.
- 2007 Times Change: The Current State of the Debate in Old World Chronology. Pp. 25-47 in *The Synchronisation of Civilisations in the Eastern Mediterranean in the Second Millennium B.C. III: Proceedings of the SCIEM 2000-2nd EuroConference, Vienna, 28th of May-1st of June 2003*. Contributions to the Chronology of the Eastern Mediterranean, Vol. 9, eds. M. Bietak and E. Czerny. Vienna, Austria: Österreichischen Akademie der Wissenschaften.
- Wilhelm, G.
- 2004 Generation Count in Hittite Chronology. Pp. 71-9 in *Mesopotamian Dark Age Revisited: Proceedings of an International Conference of SCIEM 2000, Vienna 8th-9th November 2002*. Contributions to the Chronology of the Eastern Mediterranean, Vol. 6, eds. H. Hunger and R. Pruzsinszky. Vienna, Austria: Österreichischen Akademie der Wissenschaften.
- Williams, B.
- 1975 *Archaeology and Historical Problems of the Second Intermediate Period*. Chicago: University of Chicago.

- Wiseman, D. J., and Yamauchi, E.
 1979 *Archaeology and the Bible: An Introductory Study*. Grand Rapids: Zondervan.
- Wölfli, W.
 1994 Archäologie mit einem Schwerionenbeschleuniger. *Physik in unserer Zeit* 25 no. 2: 58-66.
- Wood, B. G.
 1990 Did the Israelites Conquer Jericho? A New Look at the Archaeological Evidence. *Biblical Archaeology Review* 16 no. 2: 44-58.
- 1999 ABR's Search for the Lost Cities of the Bible. *Bible and Spade* 12 no. 3: 66-80.
- 2000 Khirbet el-Maqatir, 1995-1998. *Israel Exploration Journal* 50 no. 1-2: 123-30.
- 2005 The Rise and Fall of the 13th-Century Exodus-Conquest Theory. *Journal of the Evangelical Theological Society* 48 no. 3: 475-89.
- 2007 Locating Sodom: A Critique of the Northern Proposal. *Bible and Spade* 20 no. 3: 78-84.
- Wood, L. H.
 1945 The Kahun Papyrus and the Date of the Twelfth Dynasty. *Bulletin of the American Schools of Oriental Research* no. 99: 5-9.
- Wood, L. J.
 1986 *A Survey of Israel's History*. Grand Rapids: Zondervan.
- Wright, G. E.
 1936 The Chronology of Palestine in the Early Bronze Age. *Bulletin of the American Schools of Oriental Research* 63: 12-21.
- 1937 *The Pottery of Palestine From the Earliest Times to the End of the Early Bronze Age*. Ph.D. dissertation, Johns Hopkins University. Ann Arbor: Photo-lithoprint by Edwards Brothers.
- Yadin, Y.
 1975 *Hazor: The Rediscovery of a Great Citadel of the Bible*. New York: Random House.

- Yamaguchi, D. K.
 1986 Interpretation of Cross Correlation Between Tree-Ring Series. *Tree Ring Bulletin* 46: 47-54.
- Yeivin, S.
 1960 Early Contacts Between Canaan and Egypt. *Israel Exploration Journal* 10: 193-203.
- Yekutieli, Y.
 2009 The Har Hemar Site: A Northern Outpost on the Desert Margin? *Tel Aviv* 36: 218-40.
- Yekutieli, Y., Shalev, S., and Shilstein, S.
 2005 'En Yahav—A Copper Smelting Site in the 'Arava. *Bulletin of the American Schools of Oriental Research* 340: 1-21.
- Young, R. C.
 2004a When Did Jerusalem Fall? *Journal of the Evangelical Theological Society* 47 no. 1: 21-38.
 2004b When Was Samaria Captured? *Journal of the Evangelical Theological Society* 47 no. 4: 57-95.
 2005 Tables of Reign Lengths from the Hebrew Court Recorders. *Journal of the Evangelical Theological Society* 48 no. 2: 225-48.
- Young, R. C., and Wood, B. G.
 2008 A Critical Analysis of the Evidence from Ralph Hawkins for a Late-Date Exodus-Conquest. *Journal of the Evangelical Theological Society* 51: 225-43.
- Yuan, D. A.
 2006 *A Proposed Chronology for the Judges*. Unpublished Master of Theology Thesis. Dallas: Dallas Theological Seminary.
- Yurco, F. J.
 1990 3,200-Year-Old Picture of Israelites Found in Egypt. *Biblical Archaeology Review* 16 no. 5: 20-38.
- Zeeb, F.
 2004 The History of Alalah as a Testcase for an Ultrashort Chronology of the Mid-2nd Millennium B.C.E. Pp. 81-95 in *Mesopotamian Dark Age Revisited: Proceedings of an International Conference of SCIEM 2000, Vienna 8th–9th November 2002*. Contributions to the Chronology of the Eastern Mediterranean, Vol. 6, eds. H. Hunger and R. Pruzsinszky. Vienna, Austria: Österreichischen Akademie der Wissenschaften.